

GRAVENSTEIN UNION SCHOOL DISTRICT
3840 TWIG AVENUE
SEBASTOPOL, CA 95472

REGULAR GOVERNING BOARD
MEETING AGENDA

Wednesday, December 12, 2018
5:00 PM
Gravenstein School, Rm. 13

I. CALL TO ORDER

Jim Horn, President
Steven Schwartz, Clerk
Gregory Appling
Alexander Kahn
Jennifer Koelemeijer

II. PUBLIC COMMENTS

At this time the public may address the Board on any item not listed on the agenda. Presentations are limited to three minutes per person per topic. The Board may not respond to presentations. The public may address the Board on any item listed on the agenda at the time the matter is taken up by the Board.

III. ANNUAL REORGANIZATION MEETING

A. The Board will elect trustees to fill the following positions:

- Board President
- Board Clerk
- Voting Representative on the Sonoma County Committee on School District Organization (see information below)
- Alternate Representative, Sonoma County Committee on School District Organization

Each school board in Sonoma County appoints one representative, who, in turn, serves on a countywide committee whose sole purpose is the appointment of persons to fill vacancies on the Sonoma County Committee on School District organization. The purpose of the Sonoma County Committee on School District Organization is to develop master plans (geographic) for school district organizations in the county and approve or disapprove any proposed changes in the master plan or changes in land area between any two districts.

- B. The Board will also determine the date of monthly Board Meetings through December 2019. Currently, meetings are held the 2nd Wednesday of every month.
- C. The meeting in January 2019 is proposed for Jan 16, to accommodate the closure for winter break.
- D. Two meetings must be set for June 2019 to accommodate the annual approval of the budget and LCAP -- June 12 and 19, 2019 are proposed.

GRAVENSTEIN UNION SCHOOL DISTRICT
3840 TWIG AVENUE
SEBASTOPOL, CA 95472

IV. CONSENT AGENDA

ACTION ITEM

- A. Approve agenda order
- B. Minutes of regular meeting Nov 14 and special Board meeting Nov 16, 2018
- C. Warrants/Payroll
- D. Donations
 - 1. Megan Gorman received a grant from Rotary Club of Sebastopol for \$456 for Lego Mindstorm EV3s
 - 2. Kevin Parsons received a grant from Rotary Club of Sebastopol for \$500 for two (2) Balt Study Carrels
- E. J-13 Waivers for Gravenstein School District, Gravenstein Elementary and Hillcrest Charter for school closures due to poor air quality

Action taken/comments:

Motion _____ Second _____ Vote _____

V. GENERAL

A. Consider Approval of New Programmatic Vision

The Board will consider setting new programmatic vision for 2019-20 and beyond. The Board may consider approving the proposals discussed at the Nov 7, 2018 Board Listening Session, or some adaptation of those proposals, based on stakeholder feedback. The Board has been exploring new programmatic developments since the 2016-17 year, and providing the public with monthly opportunities to provide the Board with feedback around programmatic developments throughout the District (e.g. Kindergarten Discovery!; STEAM; Traditional; Enrich!).

Action taken/comments:

Motion _____ Second _____ Vote _____

B. Approve Contract w/ Sylvania Lighting Solutions

The Board will be asked to approve the contract with Sylvania Lighting Solutions as part of the District's Prop 39 retro fit lighting plan at a cost of \$106,235.31.

Action taken/comments:

Motion _____ Second _____ Vote _____

C. Approve New Digital Marquee for Hillcrest School

The Board is asked to approve the purchase and installation of a new digital marquee sign for the front of Hillcrest School. Cost to District is \$14,477.

Action taken/comments:

GRAVENSTEIN UNION SCHOOL DISTRICT
3840 TWIG AVENUE
SEBASTOPOL, CA 95472

Motion _____ Second _____ Vote _____

D. First Interim Report for 2018-19 School Year

The Board will receive information regarding the financial status of the District as of October 31, 2018 (the first interim period). The Board will be asked give a positive certification, meaning that the District is able to meet its financial obligations this year and for two subsequent years.

Action taken/comments:

Motion _____ Second _____ Vote _____

E. Review Facility Inspection Tool (FIT)

Supt. Schwinn will review the Facility Inspection Report completed by Brian Sposato, Head Maintenance. Supt. Schwinn will discuss the results of the inspection.

Action taken/comments:

Motion _____ Second _____ Vote _____

F. Approve Purchase of Window Coverings – Update/Action

The Board will be asked to approve a purchase of window coverings. We have selected styles for Hillcrest classrooms and the Gravenstein gym. Gravenstein classroom window coverings are awaiting one more model installation before the final decision is made.

We have secured contractors for the District's CUPCCA list. We are seeking one more contractor to provide a bid. Bids have been requested from approved vendors. The total purchase amount of (\$ TBD – Bid on its way) requires Board approval.

Action taken/comments:

Motion _____ Second _____ Vote _____

G. Approve MOU w/ MPF

The MOU with MPF is returning to the Board for approval with a small change proposed by the MPF Board. The MOU is identical to the one approved by the GUSD Board on Oct 10, 2018, with one exception – a sentence that refers to the BP 1230 is removed.

Action taken/comments:

Motion _____ Second _____ Vote _____

H. Approve Resolution #181212-1 Accounting of Developer Fees

The Board will be asked to approve resolution #181212-1, the annual accounting of developer fees.

GRAVENSTEIN UNION SCHOOL DISTRICT
3840 TWIG AVENUE
SEBASTOPOL, CA 95472

Action taken/comments:

Motion _____ Second _____ Vote _____

VI. REPORTS, AND ORAL COMMUNICATIONS

- A. Gravenstein Union Teachers' Association
- B. School Site Council
 - I. Next meeting Wed, Jan 23, 2019
- C. GSF/MPF
- D. Trustee Reports
 - I. Possible workshops for Trustees via School & College Legal Services
 - 1. Interest Based Bargaining 101, Feb 4, 2019 9am-12pm, SCOE
 - 2. Sexual Harassment prevention class March 6, 2019; 9-11am, SCOE
- E. Facilities Report
 - I. Phase 3 –Gravenstein modernization update
 - 1. Gym & kitchen, Learning Lab, Staff Restrooms
 - II. Hillcrest Middle School Improvement Project update
 - 1. Increment #2 solar parking shelter
 - III. Gravenstein Elementary solar project
- F. Gravenstein Principal's report
- G. Hillcrest Principal's report
- H. CBO Report
 - I. Update on modernization funding
- I. Superintendent Report
 - I. Board Agenda Calendar template
 - II. Enrollment update – CALPADs report Fall 1
 - III. Air Quality update

VII. PUBLIC COMMENT ON ITEMS IN CLOSED SESSION

VIII. CLOSED SESSION

A. With respect to every item of business to be discussed in closed session pursuant to Section 54957.6:

- 1) Public Employee –Hiring:
 - a. Beyond the Bell Assistant
 - b. Noon Duty Aide
 - c. Business Clerk
 - d. Teaching/Student Assistant
- 2) Conference with Labor Negotiator
 - District Negotiator: Jennifer Schwinn, Superintendent
 - Represented Employees: Gravenstein Union Teachers Assoc.

GRAVENSTEIN UNION SCHOOL DISTRICT
3840 TWIG AVENUE
SEBASTOPOL, CA 95472

- 3) Employee Discipline, Release
- 4) Superintendent Evaluation

IX. OPEN SESSION

Any reportable action taken during closed session shall be reported when the Board comes back into open session.

X. FUTURE BOARD MEETINGS:

I. Next Regular Board Meeting: Jan 16, 2019 (tentative)— 5:00 PM

XI. ADJOURNMENT

ADA Compliance: In compliance with Government Code 54954.2(a), the Gravenstein Union School District, will, on request, make this agenda available in appropriate alternative formats to persons with a disability, as required by Section 202 of the American with Disabilities Act of 1990 (42 U.S.C. 12132) and the federal rules and regulations adopted in implementation thereof. Individuals who need this agenda in an alternative format or who need a disability-related modification or accommodation in order to participate in the meeting should contact Jennifer Schwinn, District Superintendent, Gravenstein Union School District, 3840 Twig Ave., Sebastopol, CA 95472. Telephone (707) 823-7008.

November 6, 2018

To: District Superintendents and Administrative Assistant
From: Steven Herrington, Ph.D., County Superintendent of Schools
Re: Annual Organizational Meeting - Board of Education

Education Code 35143 requires each school district to hold an annual organizational meeting. Except in school districts governed by a city charter, each year the organizational meeting must be held on a day within the 15-day period commencing on the first Friday in December. Unless otherwise provided by rule of the governing board, the day and time of the meeting shall be selected by the governing board at its regular meeting held immediately prior to the first day of the 15-day period. The clerk of the board shall notify in writing all board members and board members-elect of the date and time selected for the organizational meeting.

This year the organizational meeting should be held between December 7 and December 22, 2018.*

*Note: These dates will change from year-to-year.

For school districts governed by a city charter, the organizational meeting may be held between December 15 and January 14, if so provided by board rules.

After your district's organizational meeting, please complete and return the attached form to Stefan Meholick at smeholick@scoe.org with "CERTIFICATE OF ELECTION" in the subject line. Please return the form no later than January 10, 2019.

Be sure to complete both portions of the form:

- 1) Certificate of Election of District Clerk and Board President - Include names of the board president and clerk and date(s) of regular board meeting(s).
- 2) Representative to Fill Vacancies - Indicate the name of your district's voting representative to fill vacancies on the Sonoma County Committee on School District Organization. Include the name of an alternate representative, if applicable.

Attachment: Certificate of Election form

Certificate of Election of District Clerk and Board President 2018-19

WE HEREBY CERTIFY that at a meeting of the Governing Board of the District of Sonoma County, California

at a meeting held on

the following officers were elected:

(President)

(address, including email address)

(Clerk)

(address, including email address)

Regular board meetings held

(Please indicate day of week and frequency)

Signature of Clerk or Secretary of the Governing Board

Instructions: Forward this to the County Superintendent without delay. Boards of Trustees failing to elect a clerk at the organizational meeting should notify the County Superintendent of Schools at once. If a clerk is not elected on this date, the County Superintendent of Schools shall appoint a clerk. (Education Code Sections 35022 {72402}, 35038 {724167}, 35143)

Voting Representative for Vacancies on the Sonoma County Committee on School District Organization

The county committee must have 11 members who are elected by a "voting representative" from each district. In Sonoma County, this election takes place by absentee ballot. Voting representatives do not have additional duties.

THIS CERTIFIES THAT:

(Name)

(address, including email address)

was selected as the representative of the above school District for the meeting of school board representatives to fill vacancies on the Sonoma County Committee on School District Organization. (Education Code 35023 {72403})

Selected Alternate Representative:

(Name)

Signature of Clerk or Secretary of the Governing Board

GRAVENSTEIN UNION SCHOOL DISTRICT
3840 TWIG AVENUE
SEBASTOPOL, CA 95472

REGULAR GOVERNING BOARD
MEETING MINUTES

Wednesday, Nov 14, 2018
5:00 PM
Gravenstein School, Rm. 13

I. CALL TO ORDER @ 5:05 PM

- Jim Horn, President (JH)
- Steven Schwartz, Clerk (SS)
- Gregory Appling (GA)
- Alexander Kahn (AK—arrived at 6:30 PM)
- Jennifer Koelemeijer (JK)

II. PUBLIC COMMENTS

No public comment

III. CONSENT AGENDA

ACTION ITEM

- A. Approve agenda order
- B. Minutes of regular and special Board meetings Oct 10, Oct 30 and Nov 7, 2018
- C. Warrants/Payroll
- D. GASB 75 report from CSBA
- E. Set annual organizational meeting for GUSD Board-Regular Meeting—Room 13, 5 PM, Dec 12, 2018
- F. Present final draft of updated BP/AR1230

Motion to add school closure discussion item to agenda- Motion JH –Seconded – SS 4-0

Motion to approve consent agenda with this change

Motion JH Second GA Vote 4-0

IV. GENERAL

School closure

JS and JH reviewed decisions to close our schools because of smoke from fires. All HVAC units now have higher efficiency filters designed to capture smoke particulates. JS and JH agreed that SCOE guidelines for closing schools are too lax and have been closing when PM2.5 exceeds 200.

A. Approve Single Plan for Student Achievement (SPSA)

The Board was asked to approve the Single Plan for Student Achievement for the 2018-19 school year. The SPSA includes grade level goals and strategies developed by the certificated staff and approved by the School Site Council, intended to increase student proficiency in Language Arts and Math.

JS and KP described the SPSA development process. Board members asked questions about how funds are allocated to meet goals.

GRAVENSTEIN UNION SCHOOL DISTRICT
3840 TWIG AVENUE
SEBASTOPOL, CA 95472

Motion to approve _____ GA _____ Second _____ JK _____ Vote _____ 4-0 _____

B. Consider Delegate Nominations for CSBA

The Board will consider CSBA's all-call for delegate nominations.

No action taken.

C. Approve Notice of Completion – Gravenstein Phase 3

The Board was asked to approve the Notice of Completion for Gravenstein Phase 3 Improvements, now that the project is substantially done.

After discussion on remaining issues with window leakage in some locations, motion to approve the Notice of Completion with understanding it could be rescinded within 35 days if the window issue is not resolved.

Motion _____ JH _____ Second _____ GA _____ Vote _____ 4-0 _____

D. Approve Purchase of Chromebooks

The Board was asked to approve a purchase of Chromebooks to cover a need created by the new classroom at Gravenstein. At Hillcrest, Chromebooks are needed for the STREAM Lab, Spanish and Science classrooms. The total purchase amount of \$24,011.78 requires Board approval.

Motion to approve _____ JK _____ Second _____ GA _____ Vote _____ 4-0 _____

E. Dashboard Local Indicators – Discussion Item

The Board was asked to review and discuss the District's CA Dashboard "local indicators." Local indicators for each of the District schools are required by the CDE as part of the State's accountability program. The District will use local indicators to measure progress towards goals, as described in each school's LCAP.

JS reviewed the local indicators. Board members noted some typographical/formatting issues. No action taken.

F. Consider Change to BB9320

The Board was asked to consider revising BB 9320 Board Bylaw Meetings And Notices to limit the length of regular Board meetings, as proposed by a Trustee.

After a brief discussion, the issue was tabled until the January 2019 meeting.

Motion _____ GA _____ Second _____ JK _____ Vote _____ 4-0 _____

G. Consider Breakfast Program

For the last few months, the Board has been analyzing the need for and requirements of offering a school breakfast program. The Board is asked to make a determination on whether to add such a program at this time.

GRAVENSTEIN UNION SCHOOL DISTRICT
3840 TWIG AVENUE
SEBASTOPOL, CA 95472

After a brief discussion, the issue was tabled until the January 2019 meeting.

Trustee Kahn arrived at 6:30 PM

H. Approve Resolution # 181114-1

The Board was asked to approve the resolution to set aside \$915,067 for improvements to communications, technology, modernization, energy efficiency and other capital improvements.

After discussion, motion to approve.

Motion JH Second GA Vote 5-0

I. Update on New Programmatic Developments

Supt. Schwinn reviewed the expansion of educational opportunities provided to GUSD students, including plans for the future. This item appears on the agenda monthly, allowing the public to provide the Board with feedback around programmatic developments throughout the District (e.g. Kindergarten Discovery!; STEAM; Traditional; Enrich!)

- Initial report on Nov 7. Full report expected before Dec 12, 2018.
- Leadership Team will give report on work completed this year

JS briefly reviewed the Nov. 7 listening session and described next steps. A full report will be prepared by the Superintendent's ad hoc committee, which includes GA and SS, and will be provided to the Board and community before the Dec. 12 meeting.

No action taken.

V. REPORTS, AND ORAL COMMUNICATIONS

- A. Gravenstein Union Teachers' Association
- B. School Site Council
 - I. Parent Rep voting completed
 - II. Single Plan for Student Achievement
- C. GSF/MPF
 - MPF- Amy's Dine and Donate Thursday
 - Sports Basement this week – 20% discount
 - MPF- Board meeting- Nov 27th at HMS
- D. Trustee Reports
 - GA- Attended a lot of meetings
 - SS- Suggested SCOE to look at Sup evals – Memorial at HMS was positive for some but not for others- how do we prioritize counselor's time- Analy presentation about drug use at Hillcrest
 - JK- Listening session – would have loved a text for listening session – what about for board meetings? Need better attendance at listening session

GRAVENSTEIN UNION SCHOOL DISTRICT
3840 TWIG AVENUE
SEBASTOPOL, CA 95472

JH- Also attended many meetings

JS- Constant contact message was sent regarding listening session

E. Facilities Report

I. Phase 3 –Gravenstein modernization update

1. Gym & kitchen, Learning Lab, Staff Restrooms

II. Hillcrest Middle School Improvement Project update

1. Increment #2 solar parking shelter

III. Gravenstein Elementary solar project

IV. Window coverings at both schools

1. Discussion about schedule and next steps to provide window coverings at both schools.

F. Gravenstein Principal's report

KP presented the enrichment schedule for trimester two. The Board briefly discussed if there is a need to provide additional materials in Spanish. The item may be agendaized at a later date.

G. Hillcrest Principal's report

H. CBO Report

I. Superintendent Report

JS- The enrollment report was updated to include Community Day enrollment-numbers are up- we are the only district in West County with increased enrollment

VI. PUBLIC COMMENT ON ITEMS IN CLOSED SESSION—None

VII. CLOSED SESSION—Adjourn to closed session @ 7:13 PM

A. With respect to every item of business to be discussed in closed session pursuant to Section 54957.6:

1) Public Employee –Hiring:

- a. Beyond the Bell Assistant
- b. Noon Duty Aide
- c. Business Clerk

2) Conference with Labor Negotiator

District Negotiator: Jennifer Schwinn, Superintendent

Represented Employees: Gravenstein Union Teachers Assoc.

3) Student Discipline

4) Superintendent Evaluation

VIII. OPEN SESSION @ 8:25 PM

No reportable action was taken in closed session

IX. FUTURE BOARD MEETINGS:

I. Next Regular Board Meeting: Dec 12, 2018— 5:00 PM

X. ADJOURNMENT @ 8:26 PM

Gravenstein Union School District
November Payroll Report

December 12, 2018 Regular Board Meeting

Certificated Salary & Benefits

Regular: \$ 457,158.76
Supplemental: \$ 27,166.68

Classified Salary & Benefits

Regular: \$ 97,856.04
Supplemental: \$ 5,775.30

Total Salary & Benefits

\$ 587,956.78

Checks Dated 11/01/2018 through 11/30/2018

Board Meeting Date December 12/2018

Check Number	Check Date	Pay to the Order of	Fund-Object	Comment	Expensed Amount	Check Amount
1676878	11/02/2018	American Storage LLC	40-6200	Storage Container 8x20-Const. Phase 3		124.00
1676879	11/02/2018	Banner Bank	40-6200	5% Retention for Hillcrest Improvements		4,847.93
1676880	11/02/2018	Children's Plus, Inc.	04-4310	Hillcrest -Library Books-STREAM		1,608.34
1676881	11/02/2018	Clover-Stornetta Farms Inc.	13-4700	Milk Purchases 2018-19		84.00
1676882	11/02/2018	Madelyn Davis	04-5880	Volleyball 10/16/2018		10.00
1676883	11/02/2018	Educational Data Systems, Inc. Accounting Dept.	01-4310	CELDT 2017-18 Excess Materials Charge	1.80	
1676884	11/02/2018	GCCI INC.	03-4310	CELDT 2017-18 Excess Materials Charge	21.60	
1676885	11/02/2018	Erica Gutsch	04-4310	CELDT 2017-18 Excess Materials Charge	12.60	36.00
1676886	11/02/2018	Monoprice Inc.	40-6200	Hillcrest Improvements Increment I		92,110.67
			04-5880	Volleyball 10/4/2018		10.00
			04-4310	Premium 3D Printer Filament	151.30	
				Unpaid Tax	1.23-	150.07
1676887	11/02/2018	Office Depot	01-4359	Instructional Supplies for Grav Elem/Grav First	54.15	
			04-4310	Instructional Supplies for Hillcrest Saunders - Class supplies	211.08	
1676888	11/02/2018	Safeway	04-4359	Instructional Supplies for Hillcrest	149.14	467.14
1676889	11/02/2018	Petria Sully	12-4390	Daycare Supplies & Snacks for 2018-19	52.77	103.29
1676890	11/02/2018	INDOOR AIR SCIENCES INC.	03-4310	Scholastic Books		59.34
1676891	11/02/2018	Lonny Johnson dba Ancient Artifacts	40-5830	Concrete Moisture Testing		1,195.00
1676892	11/02/2018	Clover-Stornetta Farms Inc.	04-5826	Class Presentations-Ancient Artifacts		915.00
1676893	11/02/2018	J. Stanley Correia	13-4700	Milk Purchases 2018-19	181.25	96.00
			01-5830	2018-19 Special Ed Psych Services	2,175.00	
			03-5830	2018-19 Special Ed Psych Services		3,625.00
			04-5830	2018-19 Special Ed Psych Services	1,268.75	
1676894	11/02/2018	Sierra Fiddler	04-5880	6th Grade Girls Volleyball 10/11/2018		10.00
1676895	11/02/2018	Isaac Kuster dba I.A. Kuster Const. Insp.	40-6230	DSA Class I Inspector Hillcrest Improvements	1.23-	2,700.00
1676896	11/02/2018	Steven Lee Miller	04-5880	Flag Football Referee 10/11/2018		40.00
1676897	11/02/2018	Pacific Gas & Electric	01-5520	Light Poles at Grav Elem 2018-19	1.74	
			03-5520	Light Poles at Grav Elem 2018-19	19.98	
			04-5520	Electric and Gas for 2018-19 @ Hillcrest	160.61	182.33
1676898	11/02/2018	Pearson Clinical Assessment	03-4310	Gate Testing Materials		885.55
1676899	11/02/2018	Really Good Stuff Inc.	03-4310	Class Supplies-Sully		108.20
1676900	11/02/2018	Rich Ruybalid	04-5880	Referee for Boys Flag Football 10/3/2018		40.00
1676901	11/02/2018	Sonoma County Office Of Ed.	01-5819	Agreement for Instructional Resources for 2018-19	244.35	

The preceding Checks have been issued in accordance with the District's Policy and authorization of the Board of Trustees. It is recommended that the preceding Checks be approved. (Limited to Checks issued from the COUNTY bank account.)

020 - Gravenstein Union School District

Generated for Wanda Holden (WLHOLDEN), Dec 6 2018 3:36PM

ESCAPE

ONLINE
Page 1 of 6

ReqPay12d

Board Report

Checks Dated 11/01/2018 through 11/30/2018

Board Meeting Date December 12/2018

Check Number	Check Date	Pay to the Order of	Fund-Object	Comment	Expensed Amount	Check Amount
1676901	11/02/2018	Sonoma County Office Of Ed.	03-5819	Agreement for Instructional Resources for 2018-19	2,932.20	
			04-5819	Agreement for Instructional Resources for 2018-19	1,710.45	4,887.00
1676902	11/02/2018	Verizon	01-5912	Sup't Phone & Tablet Service for 2018-19	5.06	
			03-5912	Sup't Phone & Tablet Service for 2018-19	60.71	
			04-5912	Sup't Phone & Tablet Service for 2018-19	35.42	101.19
1678171	11/07/2018	Advanced Security Systems	40-5830	Fire Alarm Bypass and Reprogram Sensors		135.00
1678172	11/07/2018	Ally Technology Consulting LLC	03-4440	Chromebooks for Gravenstein Elementary		2,750.00
1678173	11/07/2018	Music Theatre International	04-4310	Show Kit for Pirates of Penzance Jr		685.00
1678174	11/07/2018	Whitney B. Olson	04-5826	National History Day		80.00
1678175	11/07/2018	Pacific Gas & Electric	01-5520	Electric and Gas for 2018-19 Gravenstein	179.83	
			03-5520	Electric and Gas for 2018-19 Gravenstein	2,069.80	
			04-5520	Electric and Gas for 2018-19 @ Hillcrest	3,597.74	
				Electric and Gas for 2018-19 Gravenstein	25.88	5,873.25
1678176	11/07/2018	Ray Morgan Company	01-4390	Staples for Copiers		63.79
1678177	11/07/2018	Signet Testing Laboratories, Inc	40-6230	Special Testing for Hillcrest Improvements		6,958.59
1678178	11/07/2018	U.S. Bank Equipment Finance	01-5631	Copier Lease for Schools and DO for 2018-19	35.28	
			03-5631	Copier Lease for Schools and DO for 2018-19	423.38	
			04-5631	Copier Lease for Schools and DO for 2018-19	246.97	705.63
1678179	11/07/2018	West County Transportation	03-5826	Bus for K Discovery - Armstrong Woods		565.41
1678180	11/07/2018	Heather L. Johnson	04-4310	Book "Dry"		13.96
1678181	11/07/2018	Castino Restaurant & Supply	13-4390	Gravenstein- Kitchen Dishwasher Supplies		119.44
1678182	11/07/2018	Clover-Stornetta Farms Inc.	13-4700	Milk Purchases 2018-19		82.00
1678183	11/07/2018	Discount School Supply	03-4310	Magna Tiles-Crandall		130.64
1678184	11/07/2018	IXL Learning	01-4310	IXL Learning for 2018-19 year 3 of 3	245.70	
			03-4310	IXL Learning for 2018-19 year 3 of 3	2,997.54	
			04-4310	IXL Learning for 2018-19 year 3 of 3	1,670.76	4,914.00
1678185	11/07/2018	Onel Lopez	04-5880	Flag Football 9/10/2018		40.00
1678186	11/07/2018	Office Depot	01-4359	Instructional Supplies for Grav Elem/Grav First	66.71	
			03-4310	Oil/Soft Pastels	186.89	
			04-4350	School Secretary Supplies-Hillcrest	127.62	381.22
1678187	11/07/2018	Recology Sonoma Marin	01-5560	Recology-Gravenstein	31.05	

The preceding Checks have been issued in accordance with the District's Policy and authorization of the Board of Trustees. It is recommended that the preceding Checks be approved. (Limited to Checks issued from the COUNTY bank account.)

ReqPay12d

Board Report

Checks Dated 11/01/2018 through 11/30/2018

Board Meeting Date December 12/2018

Check Number	Check Date	Pay to the Order of	Fund-Object	Comment	Expensed Amount	Check Amount
1678187	11/07/2018	Recology Sonoma Marin	03-5560	Recology-Gravenstein	357.06	
1678188	11/07/2018	Rohnert Park Gymnastics	04-5560	Recology-Hillcrest	216.72	604.83
1678189	11/07/2018	Rich Ruybalid	01-5826	1st Grade All-Rohnert Park Gymnastics	255.00	
1678190	11/07/2018	Sonoma County Office Of Ed.	03-5826	1st Grade All-Rohnert Park Gymnastics	255.00	510.00
1678191	11/07/2018	Weeks Drilling & Pump Co. Inc.	04-5880	Referee for Boys Flag Football 10/9/2018		70.00
			03-5200	Behavior Interventions and Supports		200.00
			01-5530	Gravenstein Elem Water Service for 2018-19	18.40	
			03-5530	Gravenstein Elem Water Service for 2018-19	211.60	
1678192	11/07/2018	Jennifer P. Schwinn	04-5530	Hillcrest Water Service for 2018-19	240.86	470.86
1678193	11/07/2018	Stephanie Barclay	01-4350	School Board Listening Session -Supplies	7.02	
1678194	11/07/2018	Mark Bradski	03-4350	School Board Listening Session -Supplies	84.23	
1678195	11/07/2018	Houghton Mifflin Harcourt	04-4350	School Board Listening Session -Supplies	49.13	140.38
1678196	11/07/2018	Isaac Kuster dba I.A. Kuster Const. Insp.	03-5830	2018-19 Dance Enrichment Tri 1		1,440.00
			03-5830	Science/STEM Classes Instruction		7,000.00
			04-4110	Go Math! 1 for Hillcrest- Additional books		90.28
			40-6230	DSA Class I Inspector Gravenstein Phase III		1,800.00
1678197	11/07/2018	Marta Pedersen	03-5830	2018-19 Art Enrichment Tri 1		960.00
1678198	11/07/2018	Nancy Prehlich	03-5830	2018-19 Drama Enrichment Tri 1		2,540.00
1678199	11/07/2018	Ray Morgan Company	04-4359	Staples for Copiers-Hillcrest		152.02
1678200	11/07/2018	Nancy Ricciardi	03-5830	2018-19 Art Enrichment		7,565.00
1678201	11/07/2018	The Great Burro Studios	03-5830	2018-19 Music Enrichment Tri 1		1,199.88
1678202	11/07/2018	The Program, Youth Skill Dev	03-5830	2018-19 Athletic Enrichment Tri 1		1,994.00
1680832	11/21/2018	Renee L. Lott	03-4350	"Taking Diabetes to School"		14.00
1680833	11/21/2018	AXIA	40-6210	Gravenstein Modernization, Phase III (Part 2)		3,263.59
1680834	11/21/2018	Clover-Storretta Farms Inc.	13-4700	Milk Purchases 2018-19		36.00
1680835	11/21/2018	Creative Window Fashions Inc.	03-4400	Window Coverings for Gravenstein		2,583.56
1680836	11/21/2018	Fishman Supply Company	01-4370	District Custodial Supplies	5.22	
			03-4370	District Custodial Supplies	62.65	
			04-4370	District Custodial Supplies	36.54	104.41
1680837	11/21/2018	Office Depot	03-4310	BTB and Gorman Supplies	10.94	
			04-4350	School Secretary Supplies-Hillcrest	115.12	
			12-4390	BTB and Gorman Supplies	51.13	177.19
1680838	11/21/2018	Ray Morgan Company	04-4359	Staples for Copiers-Hillcrest		152.02
1680839	11/21/2018	School Nurse Supply, Inc	03-4390	School Nurse Supplies- Gravenstein		26.86

The preceding Checks have been issued in accordance with the District's Policy and authorization of the Board of Trustees. It is recommended that the preceding Checks be approved. (Limited to Checks issued from the COUNTY bank account.)

020 - Gravenstein Union School District

Generated for Wanda Holden (WLHOLDEN), Dec 6 2018 3:36PM

Checks Dated 11/01/2018 through 11/30/2018

Check Number	Check Date	Pay to the Order of	Fund-Object	Comment	Expensed Amount	Check Amount
1680840	11/21/2018	SYTech Solutions	01-5830	Document Management Services 2018-19	12.53	
			03-5830	Document Management Services 2018-19	150.30	
			04-5830	Document Management Services 2018-19	87.67	250.50
1680841	11/21/2018	T&b Sports	04-4400	Hillcrest-Volleyball Net System		4,864.54
1680842	11/21/2018	Suzanne M. Mattish	03-4310	WeVideo Subscription 1 year 30 seats		199.00
1680843	11/21/2018	Kerilee C. Pugno	01-4390	Breakfast for students in need	1.56	
			03-4390	Breakfast for students in need	17.99	19.55
1680844	11/21/2018	Renee L. Lott	01-4390	Listening Session Drinks		18.76
1680845	11/21/2018	ACSIG	01-9573	Employee's Dental Plan Coverage 2018-19		8,372.00
1680846	11/21/2018	AED Authority	01-4400	AED Concierge Service for GUSD	19.60	
			03-4400	AED Concierge Service for GUSD	225.40	
			04-4400	AED Concierge Service for GUSD	195.00	440.00
1680847	11/21/2018	AT&T Calnet 3	01-5911	Gravenstein AT&T CALNET 3 Charges 2018-19	25.15	
			03-5911	Gravenstein AT&T CALNET 3 Charges 2018-19	299.89	
			04-5911	Gravenstein AT&T CALNET 3 Charges 2018-19	149.47	534.98
1680848	11/21/2018	Banner Bank	40-6200	Hillcrest AT&T CALNET 3 Charges 2018-19	60.47	14,625.66
1680849	11/21/2018	Calif Dept of Parks and Rec	03-5826	5% Retention for Gravenstein Phase III		200.00
1680850	11/21/2018	California's Valued Trust	01-9572	Sonoma Mission/General Vallejo Home Employee's CVT Health Plan Coverage 2018-19		43,954.00
1680851	11/21/2018	Counterpoint Construction Services, Inc.	40-9510	Gravenstein -Phase 3 Project Document Control	1,580.00	
				Hillcrest Middle-Increment 1 Project Doc. Control	1,775.00	3,355.00
1680852	11/21/2018	GCCI INC.	40-6200	Gravenstein Elementary School Phase III		277,887.53
1680853	11/21/2018	Grainger Inc.	01-4370	Furnace Filters for All Classrooms	13.98	
			03-4370	Furnace Filters for All Classrooms	167.86	
			04-4370	Furnace Filters for All Classrooms	97.92	279.76
1680854	11/21/2018	Sebastopol Lock Shop	03-5630	Gravenstein School-Locksmit Services		126.31
1680855	11/21/2018	The Great Burro Studios	03-5830	2018-19 Music Enrichment Tri 1		533.28
1680856	11/21/2018	Vision Service Plan	01-9574	Employee's Vision Plan Coverage 2018-19		1,801.80
1682024	11/28/2018	Megan K. Gorman	03-4310	TV Mounting Hardware		43.45
1682025	11/28/2018	Advanced Security Systems	40-5830	Fire Alarm Bypass and Reprogram Sensors		135.00
1682026	11/28/2018	American Storage LLC	40-6200	Storage Container 8x20-Const. Phase 3		124.00

The preceding Checks have been issued in accordance with the District's Policy and authorization of the Board of Trustees. It is recommended that the preceding Checks be approved. (Limited to Checks issued from the COUNTY bank account.)

020 - Gravenstein Union School District

Checks Dated 11/01/2018 through 11/30/2018

Board Meeting Date December 12/2018

Check Number	Check Date	Pay to the Order of	Fund-Object	Comment	Expensed Amount	Check Amount
1682027	11/28/2018	California Academy of Sciences c/o Contact Center	04-5826	6th Grade Class Field Trip 12/20/2018		1,044.75
1682028	11/28/2018	Clover-Stormetta Farms Inc.	13-4700	Milk Purchases 2018-19		70.00
1682029	11/28/2018	Grainger Inc.	01-4370	Furnace Filters for All Classrooms	48.26	
			03-4370	Furnace Filters for All Classrooms	579.08	
			04-4370	Furnace Filters for All Classrooms	337.79	965.13
1682030	11/28/2018	MCI Comm Service	12-5911	Daycare Phone Line for 2018-19		13.72
1682031	11/28/2018	Museum of the American Indian	03-5826	Museum of the American Indian		740.00
1682032	11/28/2018	Office Depot	01-4359	Instructional Supplies for Grav Elem/Grav First		54.06
1682033	11/28/2018	Ray Morgan Company	01-5633	Copier Contract Charges 2018-19		1,303.46
1682034	11/28/2018	School Outfitters	04-4440	Headphones - Hillcrest		480.72
1682035	11/28/2018	Scribbles and Giggles	03-5826	K All field trip Scribbles and Giggles 12/12/2018		560.00
1682036	11/28/2018	Sebastopol Lock Shop	04-4370	Key/locks for Hillcrest		59.88
1682037	11/28/2018	All Volleyball, Inc.	04-4310	Volleyballs for Hillcrest		289.50
				Unpaid Tax	23.52-	
1682038	11/28/2018	Clover-Stormetta Farms Inc.	13-4700	Milk Purchases 2018-19		8,073.46
1682039	11/28/2018	McGraw-Hill School Education	01-4110	Open Court ELA Grades 1-5 Account #247107		93.50
				Open Court ELA Grades K-5 Account #247107	1,230.00	
			03-4110	Open Court ELA Grades 1-5 Account #247107	75,864.86	
				Open Court ELA Grades K-5 Account #247107	24,515.24	109,683.56
1682040	11/28/2018	Office Depot	01-4359	Instructional Supplies for Grav Elem/Grav First		77.20
			04-4350	School Secretary Supplies-Hillcrest	60.73	137.93
				Total Number of Checks	99	644,250.19
				Fund Recap		
			Fund	Description	Check Count	Expensed Amount
			01	General Fund	30	66,402.17
			03	Gravenstein Elementary Charte	46	146,113.68
			04	Hillcrest Middle Charter	42	21,748.04
			12	Child Development Fund	3	168.14

The preceding Checks have been issued in accordance with the District's Policy and authorization of the Board of Trustees. It is recommended that the preceding Checks be approved. (Limited to Checks issued from the COUNTY bank account.)

020 - Gravenstein Union School District

Generated for Wanda Holden (WLHOLDEN), Dec 6 2018 3:36PM

ReqPay12d

Board Report

Checks Dated 11/01/2018 through 11/30/2018

Board Meeting Date December 12/2018

Check Number	Check Date	Pay to the Order of	Fund-Object	Comment	Expensed Amount	Check Amount
--------------	------------	---------------------	-------------	---------	-----------------	--------------

Fund Recap

Fund	Description	Check Count	Expensed Amount
13	Cafeteria Fund	7	580.94
40	Special Reserve-capital Proj	14	409,261.97
	Total Number of Checks	99	644,274.94
	Less Unpaid Tax Liability		24.75
	Net (Check Amount)		644,250.19

Includes checks for only Bank Account COUNTY

The preceding Checks have been issued in accordance with the District's Policy and authorization of the Board of Trustees. It is recommended that the preceding Checks be approved. (Limited to Checks issued from the COUNTY bank account.)

020 - Gravenstein Union School District

U

Larry Ford, President 2018-19
November 18, 2018



Kerilee Pugno, Principal
Gravenstein Elementary / Community Day School
3840 Twig Avenue
Sebastopol, CA 95472-5750

Congratulations! The Rotary Club of Sebastopol is pleased to announce that the following Mark Sell Rotary Teacher Grants have been awarded to teachers at your school.

Kevin Parsons	\$500	Two Balt Study Carrels
Megan Gorman	\$456	Lego Mindstorm EV3s

Enclosed is a check. Please disburse the amounts to each teacher for the projects listed above.

Unfortunately we were not able to award grants to all who applied. The list below shows applications that were considered but not awarded. On behalf of the Rotary Club of Sebastopol, please thank these teachers for applying and encourage them to apply again in future..

Aimee Otterson	\$0	Subscribe to an online reading and literacy program through Reading A-Z.
----------------	-----	--

The Mark Sell Rotary Teacher Grant Program is funded entirely by our annual crab feed which will take place on February 9, 2019. Please encourage your school community to support this program by attending the best crab feed in Sonoma County, which includes all you can eat fresh cooked crab, chowder, salad, unlimited wine with dinner, dessert, music, dancing, and lots of fun. Tickets will go on sale in December at www.sebastopolrotary.org.

To date the Rotary Club of Sebastopol has awarded over \$280,000 to West County teachers through this program thanks to the generosity of our members, friends, and neighbors. The next round of grants will take place in Spring 2019; see www.sebastopolrotary.org for details.

Sincerely,

Jack Blasco
Chair, Mark Sell Rotary Teacher Grant Committee

CALIFORNIA DEPARTMENT OF EDUCATION
REQUEST FOR ALLOWANCE OF ATTENDANCE DUE TO EMERGENCY CONDITIONS
 FORM J-13A, REVISED DECEMBER 2017

SECTION A: REQUEST INFORMATION

- This form is used to obtain approval of attendance and instructional time credit pursuant to *Education Code (EC)* sections 41422, 46200, 46391, 46392 and *California Code of Regulations (CCR)*, Title 5, Section 428.
- Only schools that report Principal Apportionment average daily attendance (ADA) for the purpose of calculating a K-12 Local Control Funding Formula (LCFF) entitlement should submit this form.
- Refer to the instructions and frequently asked questions at <https://www.cde.ca.gov/vfg/aa/paf/j13a.asp> for information regarding the completion of this form.

PART I: LOCAL EDUCATIONAL AGENCY (LEA)

LEA NAME: Gravenstein Union School District	COUNTY CODE: 49	DISTRICT CODE: 70714	CHARTER NUMBER (IF APPLICABLE):
LEA SUPERINTENDENT OR ADMINISTRATOR NAME: Jennifer Schwinn	FISCAL YEAR: 2018-19		
ADDRESS: 3840 Twig Avenue	COUNTY NAME: Sonoma		
CITY: Sebastopol	STATE: CA	ZIP CODE: 95472	
CONTACT NAME: Wanda Holden	PHONE: 707-823-7008	E-MAIL: wholden@grav.k12.ca.us	

PART II: LEA TYPE AND SCHOOL SITE INFORMATION APPLICABLE TO THIS REQUEST (Choose only one LEA type):

<input checked="" type="checkbox"/> SCHOOL DISTRICT Choose one of the following: <input checked="" type="checkbox"/> All district school sites <input type="checkbox"/> Select district school sites	<input type="checkbox"/> COUNTY OFFICE OF EDUCATION (COE) Choose one of the following: <input type="checkbox"/> All COE school sites <input type="checkbox"/> Select COE school sites	<input type="checkbox"/> CHARTER SCHOOL
---	--	---

PART III: CONDITION(S) APPLICABLE TO THIS REQUEST:

<p><input checked="" type="checkbox"/> SCHOOL CLOSURE: When one or more schools were closed because of conditions described in EC Section 41422. LCFF apportionments should be maintained and instructional time credited in Section B for the school(s) without regard to the fact that the school(s) were closed on the dates listed, due to the nature of the emergency. Approval of this request authorizes the LEA to disregard these days in the computation of ADA (per EC Section 41422) without applicable penalty and obtain credit for instructional time for the days and the instructional minutes that would have been regularly offered on those days pursuant to EC Section 46200, et seq.</p> <p><input type="checkbox"/> There was a Declaration of a State of Emergency by the Governor of California during the dates associated with this request.</p>
<p><input type="checkbox"/> MATERIAL DECREASE: When one or more schools were kept open but experienced a material decrease in attendance pursuant to EC Section 46392 and CCR, Title 5, Section 428. Material decrease requests that include all school sites within the school district must demonstrate that the school district as a whole experienced a material decrease in attendance. Material decrease requests for one or more but not all sites within the school district must show that each site included in the request experienced a material decrease in attendance pursuant to EC Section 46392 and CCR, Title 5, Section 428. The request for substitution of estimated days of attendance for actual days of attendance is in accordance with the provisions of EC Section 46392. Approval of this request will authorize use of the estimated days of attendance in the computation of LCFF apportionments for the described school(s) and dates in Section C during which school attendance was materially decreased due to the nature of the emergency.</p> <p><input type="checkbox"/> There was a Declaration of a State of Emergency by the Governor of California during the dates associated with this request.</p>
<p><input type="checkbox"/> LOST OR DESTROYED ATTENDANCE RECORDS: When attendance records have been lost or destroyed as described in EC Section 46391. Requesting the use of estimated attendance in lieu of attendance that cannot be verified due to the loss or destruction of attendance records. This request is made pursuant to EC Section 46391:</p> <p><i>"Whenever any attendance records of any district have been lost or destroyed, making it impossible for an accurate report on average daily attendance for the district for any fiscal year to be rendered, which fact shall be shown to the satisfaction of the Superintendent of Public Instruction by the affidavits of the members of the governing board of the district and the county superintendent of schools, the Superintendent of Public Instruction shall estimate the average daily attendance of such district. The estimated average daily attendance shall be deemed to be the actual average daily attendance for that fiscal year for the making of apportionments to the school district from the State School Fund."</i></p>

SECTION B: SCHOOL CLOSURE

PART I: NATURE OF EMERGENCY (Describe in detail.)

- Not Applicable (Proceed to Section C)
 Supplemental Page(s) Attached

All schools in the District were closed due to poor air quality. The quality of the air during the closures was unhealthy or hazardous. The ash left on the school grounds was toxic. I have attached documentation to show the quality of the air and to demonstrate the requirement for time to clean classrooms and playground and lunch areas for student and staff safety. During the closures, the custodial staff also replaced the HVAC system filters installing a more efficient type.

PART II: SCHOOL INFORMATION (Use the supplemental Excel form at <https://www.cde.ca.gov/fg/aa/pa/13a.asp> if more than 10 lines are needed for this request. Attach a copy of a school calendar. If the request is for multiple school sites, and the sites have differing school calendars, attach a copy of each different school calendar to the request.)

A	B	C	D	E	F	G	H	I
School Name	School Code	Site Type	Days in School Calendar	Emergency Days Built In	Built In Emergency Days Used	Date(s) of Emergency Closure	Closure Dates Requested	Total Number of Days Requested
Gravenstein First	0126888	Traditional	180	0	NA	11/9, 11/13, 11/14, 11/16	4	4
Gravenstein Community Day School	6119655	Community	180	0	NA	11/9, 11/13, 11/14, 11/16	4	4

PART III: CLOSURE HISTORY (List closure history for all schools in Part II. Refer to the instructions for an example.)

A	B	C	D	E	F
School Name	School Code	Fiscal Year	Closure Dates	Nature	Weather Related Yes/No
Gravenstein First	0126888	2018-19	11/9, 11/13, 11/14, 11/16	Poor air quality due to smoke from wild fires in Butte County	Y
Gravenstein Community Day School	6119655	2018-19	11/9, 11/13, 11/14, 11/16	Poor air quality due to smoke from wild fires in Butte County	Y
Gravenstein First	0126888	2017-18	10/9, 10/10, 10/11, 10/12, 10/13, 10/16	Wild fires in Sonoma County	Y
Gravenstein Community Day School	6119655	2017-18	10/9, 10/10, 10/11, 10/12, 10/13, 10/16	Wild fires in Sonoma County	Y
Gravenstein First	0126888	2016-17	1/11	Flooding & road closures in Sonoma County	Y
Gravenstein Community Day School	6119655	2016-17	1/11	Flooding & road closures in Sonoma County	Y
Gravenstein First	0126888	2014-15	12/11, 12/12	Flooding & road closures in Sonoma County	Y
Gravenstein Community Day School	6119655	2014-15	12/11, 12/12	Flooding & road closures in Sonoma County	Y

CALIFORNIA DEPARTMENT OF EDUCATION
REQUEST FOR ALLOWANCE OF ATTENDANCE DUE TO EMERGENCY CONDITIONS
FORM J-13A, REVISED DECEMBER 2017

Not Applicable (Proceed to Section E)

SECTION D: LOST OR DESTROYED ATTENDANCE RECORDS

PART I: PERIOD OF REQUEST The entire period covered by the lost or destroyed records commences with _____ up to and including _____.

PART II: CIRCUMSTANCES (Describe below circumstances and extent of records lost or destroyed.)

[Empty box for describing circumstances and extent of records lost or destroyed.]

PART III: PROPOSAL (Describe below the proposal to reconstruct attendance records or estimate attendance in the absence of records.)

[Empty box for describing the proposal to reconstruct attendance records or estimate attendance in the absence of records.]

CALIFORNIA DEPARTMENT OF EDUCATION
REQUEST FOR ALLOWANCE OF ATTENDANCE DUE TO EMERGENCY CONDITIONS
FORM J-13A, REVISED DECEMBER 2017

SECTION E: AFFIDAVIT

PART I: AFFIDAVIT OF SCHOOL DISTRICT, COUNTY OFFICE OF EDUCATION, OR CHARTER SCHOOL GOVERNING BOARD MEMBERS – All applicable sections below must be completed to process this J-13A request.

We, members constituting a majority of the governing board of Gravenstein Union School District, hereby swear (or affirm) that the foregoing statements are true and are based on official records.

Board Members Signatures

<u>Jim Horn</u>	_____	_____
<u>Steve Schwartz</u>	_____	_____
<u>Gregory Appling</u>	_____	_____
<u>Alexander Kahn</u>	_____	_____
<u>Jennifer Koelemeijer</u>	_____	_____
_____	_____	_____
_____	_____	_____
_____	_____	_____
_____	_____	_____

At least a majority of the members of the governing board shall execute this affidavit.

Subscribed and sworn (or affirmed) before me, this 12th day of December, 2018

Witness: Jennifer Schwinn _____ Title: Superintendent of Sonoma _____ County, California
(Name) (Signature)

PART II: APPROVAL BY SUPERINTENDENT OF CHARTER SCHOOL AUTHORIZER (Only applicable to charter school requests)

Superintendent (or designee): _____ (Name) _____ (Signature) Authorizing LEA Name: _____

PART III: AFFIDAVIT OF COUNTY SUPERINTENDENT OF SCHOOLS

The information and statements contained in the foregoing request are true and correct to the best of my knowledge and belief.

County Superintendent of Schools (or designee): Steve Herrington _____ (Name) _____ (Signature)

Subscribed and sworn (or affirmed) before me, this _____ day of _____

Witness: Shelley Stiles _____ Title: Director of Sonoma _____ County, California
(Name) (Signature)

COE contact/individual responsible for completing this section:

Name: Shelley Stiles _____ Title: Director, External Fiscal Services Phone: 707-542-2635 E-mail: sstiles@scoe.org

CALIFORNIA DEPARTMENT OF EDUCATION
REQUEST FOR ALLOWANCE OF ATTENDANCE DUE TO EMERGENCY CONDITIONS
 FORM J-13A, REVISED DECEMBER 2017

SECTION A: REQUEST INFORMATION

- This form is used to obtain approval of attendance and instructional time credit pursuant to *Education Code (EC)* sections 41422, 46200, 46391, 46392 and *California Code of Regulations (CCR)*, Title 5, Section 428.
- Only schools that report Principal Apportionment average daily attendance (ADA) for the purpose of calculating a K-12 Local Control Funding Formula (LCFF) entitlement should submit this form.
- Refer to the instructions and frequently asked questions at <https://www.cde.ca.gov/fj/aa/paj/j13a.asp> for information regarding the completion of this form.

PART I: LOCAL EDUCATIONAL AGENCY (LEA)

LEA NAME: Gravenstein Elementary School	COUNTY CODE: 49	DISTRICT CODE: 70714	CHARTER NUMBER (IF APPLICABLE): 1445
LEA SUPERINTENDENT OR ADMINISTRATOR NAME: Jennifer Schwinn	FISCAL YEAR: 2018-19		
ADDRESS: 3840 Twig Avenue	COUNTY NAME: Sonoma		
CITY: Sebastopol	STATE: CA	ZIP CODE: 95472	
CONTACT NAME: Wanda Holden	TITLE: Chief Business Officer	PHONE: 707-823-7008	E-MAIL: wholden@grav.k12.ca.us

PART II: LEA TYPE AND SCHOOL SITE INFORMATION APPLICABLE TO THIS REQUEST (Choose only one LEA type):

<input type="checkbox"/> SCHOOL DISTRICT Choose one of the following: <input type="checkbox"/> All district school sites <input type="checkbox"/> Select district school sites	<input type="checkbox"/> COUNTY OFFICE OF EDUCATION (COE) Choose one of the following: <input type="checkbox"/> All COE school sites <input type="checkbox"/> Select COE school sites	<input checked="" type="checkbox"/> CHARTER SCHOOL
---	--	--

PART III: CONDITION(S) APPLICABLE TO THIS REQUEST:

<input checked="" type="checkbox"/> SCHOOL CLOSURE: When one or more schools were closed because of conditions described in EC Section 41422. LCFF apportionments should be maintained and instructional time credited in Section B for the school(s) without regard to the fact that the school(s) were closed on the dates listed, due to the nature of the emergency. Approval of this request authorizes the LEA to disregard these days in the computation of ADA (per EC Section 41422) without applicable penalty and obtain credit for instructional time for the days and the instructional minutes that would have been regularly offered on those days pursuant to EC Section 46200, et seq. <input type="checkbox"/> There was a Declaration of a State of Emergency by the Governor of California during the dates associated with this request.
<input type="checkbox"/> MATERIAL DECREASE: When one or more schools were kept open but experienced a material decrease in attendance pursuant to EC Section 46392 and CCR, Title 5, Section 428. Material decrease requests that include all school sites within the school district must demonstrate that the school district as a whole experienced a material decrease in attendance. Material decrease requests for one or more but not all sites within the school district must show that each site included in the request experienced a material decrease in attendance pursuant to EC Section 46392 and CCR, Title 5, Section 428. The request for substitution of estimated days of attendance for actual days of attendance is in accordance with the provisions of EC Section 46392. Approval of this request will authorize use of the estimated days of attendance in the computation of LCFF apportionments for the described school(s) and dates in Section C during which school attendance was materially decreased due to the nature of the emergency. <input type="checkbox"/> There was a Declaration of a State of Emergency by the Governor of California during the dates associated with this request.
<input type="checkbox"/> LOST OR DESTROYED ATTENDANCE RECORDS: When attendance records have been lost or destroyed as described in EC Section 46391. Requesting the use of estimated attendance in lieu of attendance that cannot be verified due to the loss or destruction of attendance records. This request is made pursuant to EC Section 46391: <i>"Whenever any attendance records of any district have been lost or destroyed, making it impossible for an accurate report on average daily attendance for the district for any fiscal year to be rendered, which fact shall be shown to the satisfaction of the Superintendent of Public Instruction by the affidavits of the members of the governing board of the district and the county superintendent of schools, the Superintendent of Public Instruction shall estimate the average daily attendance of such district. The estimated average daily attendance shall be deemed to be the actual average daily attendance for that fiscal year for the making of apportionments to the school district from the State School Fund."</i>

SECTION D: LOST OR DESTROYED ATTENDANCE RECORDS

PART I: PERIOD OF REQUEST The entire period covered by the lost or destroyed records commences with _____ up to and including _____

Not Applicable (Proceed to Section E)

PART II: CIRCUMSTANCES (Describe below circumstances and extent of records lost or destroyed.)

[Empty box for describing circumstances and extent of records lost or destroyed.]

PART III: PROPOSAL (Describe below the proposal to reconstruct attendance records or estimate attendance in the absence of records.)

[Empty box for describing the proposal to reconstruct attendance records or estimate attendance in the absence of records.]

CALIFORNIA DEPARTMENT OF EDUCATION
REQUEST FOR ALLOWANCE OF ATTENDANCE DUE TO EMERGENCY CONDITIONS
FORM J-13A, REVISED DECEMBER 2017

SECTION E: AFFIDAVIT

PART I: AFFIDAVIT OF SCHOOL DISTRICT, COUNTY OFFICE OF EDUCATION, OR CHARTER SCHOOL GOVERNING BOARD MEMBERS – All applicable sections below must be completed to process this J-13A request.

We, members constituting a majority of the governing board of Gravenstein Elementary School, hereby swear (or affirm) that the foregoing statements are true and are based on official records.

Board Members Signatures

Board Members Names

Jim Horn	_____
Steve Schwartz	_____
Gregory Appling	_____
Alexander Kahn	_____
Jennifer Koelemeijer	_____
_____	_____
_____	_____
_____	_____
_____	_____
_____	_____
_____	_____

At least a majority of the members of the governing board shall execute this affidavit.

Subscribed and sworn (or affirmed) before me, this 12th day of December 2018

Witness: Jennifer Schwinn (Name) _____ Title: Superintendent of Sonoma County, California
(Signature) _____

PART II: APPROVAL BY SUPERINTENDENT OF CHARTER SCHOOL AUTHORIZER (Only applicable to charter school requests)

Superintendent (or designee): Jennifer Schwinn (Name) _____ Authorizing LEA Name: Gravenstein Union School District
(Signature) _____

PART III: AFFIDAVIT OF COUNTY SUPERINTENDENT OF SCHOOLS

The information and statements contained in the foregoing request are true and correct to the best of my knowledge and belief.

County Superintendent of Schools (or designee): Steve Herrington (Name) _____ (Signature) _____

Subscribed and sworn (or affirmed) before me, this _____ day of _____

Witness: Shelley Stiles (Name) _____ Title: Director of Sonoma County, California
(Signature) _____

COE contact/individual responsible for completing this section:

Name: Shelley Stiles Title: Director, External Fiscal Services Phone: 707-542-2635 E-mail: sstiles@scoe.org

CALIFORNIA DEPARTMENT OF EDUCATION
REQUEST FOR ALLOWANCE OF ATTENDANCE DUE TO EMERGENCY CONDITIONS
 FORM J-13A, REVISED DECEMBER 2017

SECTION A: REQUEST INFORMATION

- This form is used to obtain approval of attendance and instructional time credit pursuant to *Education Code (EC)* sections 41422, 46200, 46391, 46392 and *California Code of Regulations (CCR)*, Title 5, Section 428.
- Only schools that report Principal Apportionment average daily attendance (ADA) for the purpose of calculating a K-12 Local Control Funding Formula (LCFF) entitlement should submit this form.
- Refer to the instructions and frequently asked questions at <https://www.cde.ca.gov/fg/aa/pal/13a.asp> for information regarding the completion of this form.

PART I: LOCAL EDUCATIONAL AGENCY (LEA)

LEA NAME: Hillcrest Middle School	COUNTY CODE: 49	DISTRICT CODE: 70714	CHARTER NUMBER (IF APPLICABLE): 1444
LEA SUPERINTENDENT OR ADMINISTRATOR NAME: Jennifer Schwinn	FISCAL YEAR: 2018-19		
ADDRESS: 725 Bloomfield Rd.	COUNTY NAME: Sonoma		
CITY: Sebastopol	STATE: CA	ZIP CODE: 95472	
CONTACT NAME: Wanda Holden	PHONE: 707-823-7008	E-MAIL: wholden@grav.k12.ca.us	

PART II: LEA TYPE AND SCHOOL SITE INFORMATION APPLICABLE TO THIS REQUEST (Choose only one LEA type):

<input type="checkbox"/> SCHOOL DISTRICT Choose one of the following: <input type="checkbox"/> All district school sites <input type="checkbox"/> Select district school sites	<input type="checkbox"/> COUNTY OFFICE OF EDUCATION (COE) Choose one of the following: <input type="checkbox"/> All COE school sites <input type="checkbox"/> Select COE school sites	<input checked="" type="checkbox"/> CHARTER SCHOOL
---	--	--

PART III: CONDITION(S) APPLICABLE TO THIS REQUEST:

<input checked="" type="checkbox"/> SCHOOL CLOSURE: When one or more schools were closed because of conditions described in EC Section 41422, LCFF apportionments should be maintained and instructional time credited in Section B for the school(s) without regard to the fact that the school(s) were closed on the dates listed, due to the nature of the emergency. Approval of this request authorizes the LEA to disregard these days in the computation of ADA (per EC Section 41422) without applicable penalty and obtain credit for instructional time for the days and the instructional minutes that would have been regularly offered on those days pursuant to EC Section 46200, et seq. <input type="checkbox"/> There was a Declaration of a State of Emergency by the Governor of California during the dates associated with this request.
<input type="checkbox"/> MATERIAL DECREASE: When one or more schools were kept open but experienced a material decrease in attendance pursuant to EC Section 46392 and CCR, Title 5, Section 428. Material decrease requests that include all school sites within the school district must demonstrate that the school district as a whole experienced a material decrease in attendance. Material decrease requests for one or more but not all sites within the school district must show that each site included in the request experienced a material decrease in attendance pursuant to EC Section 46392 and CCR, Title 5, Section 428. The request for substitution of estimated days of attendance for actual days of attendance is in accordance with the provisions of EC Section 46392. Approval of this request will authorize use of the estimated days of attendance in the computation of LCFF apportionments for the described school(s) and dates in Section C during which school attendance was materially decreased due to the nature of the emergency. <input type="checkbox"/> There was a Declaration of a State of Emergency by the Governor of California during the dates associated with this request.
<input type="checkbox"/> LOST OR DESTROYED ATTENDANCE RECORDS: When attendance records have been lost or destroyed as described in EC Section 46391. Requesting the use of estimated attendance in lieu of attendance that cannot be verified due to the loss or destruction of attendance records. This request is made pursuant to EC Section 46391: <i>"Whenever any attendance records of any district have been lost or destroyed, making it impossible for an accurate report on average daily attendance for the district for any fiscal year to be rendered, which fact shall be shown to the satisfaction of the Superintendent of Public Instruction by the affidavits of the members of the governing board of the district and the county superintendent of schools, the Superintendent of Public Instruction shall estimate the average daily attendance of such district. The estimated average daily attendance shall be deemed to be the actual average daily attendance for that fiscal year for the making of apportionments to the school district from the State School Fund."</i>

CALIFORNIA DEPARTMENT OF EDUCATION
REQUEST FOR ALLOWANCE OF ATTENDANCE DUE TO EMERGENCY CONDITIONS
FORM J-13A, REVISED DECEMBER 2017

SECTION D: LOST OR DESTROYED ATTENDANCE RECORDS

PART I: PERIOD OF REQUEST The entire period covered by the lost or destroyed records commences with _____ up to and including _____

PART II: CIRCUMSTANCES (Describe below circumstances and extent of records lost or destroyed.)

Not Applicable (Proceed to Section E)

[Empty box for Part II: Circumstances]

PART III: PROPOSAL (Describe below the proposal to reconstruct attendance records or estimate attendance in the absence of records.)

[Empty box for Part III: Proposal]

CALIFORNIA DEPARTMENT OF EDUCATION
REQUEST FOR ALLOWANCE OF ATTENDANCE DUE TO EMERGENCY CONDITIONS
FORM J-13A, REVISED DECEMBER 2017

SECTION E: AFFIDAVIT

PART I: AFFIDAVIT OF SCHOOL DISTRICT, COUNTY OFFICE OF EDUCATION, OR CHARTER SCHOOL GOVERNING BOARD MEMBERS – All applicable sections below must be completed to process this J-13A request.

We, members constituting a majority of the governing board of Hillcrest Middle School, hereby swear (or affirm) that the foregoing statements are true and are based on official records.

Board Members Signatures

Jim Horn
Steve Schwartz
Gregory Appling
Alexander Kahn
Jennifer Koelmeijer

At least a majority of the members of the governing board shall execute this affidavit.

Subscribed and sworn (or affirmed) before me, this 12th day of December, 2018

Witness: Jennifer Schwinn (Name) _____ Title: Superintendent of Sonoma County, California (Signature)

PART II: APPROVAL BY SUPERINTENDENT OF CHARTER SCHOOL AUTHORIZER (Only applicable to charter school requests)

Superintendent (or designee): Jennifer Schwinn (Name) _____ Authorizing LEA Name: Gravenstein Union School District (Signature)

PART III: AFFIDAVIT OF COUNTY SUPERINTENDENT OF SCHOOLS

The information and statements contained in the foregoing request are true and correct to the best of my knowledge and belief.

County Superintendent of Schools (or designee): Steve Herrington

Subscribed and sworn (or affirmed) before me, this _____ day of _____ (Name) _____ (Signature)



Witness: Shelley Stiles (Name) _____ Title: Director of Sonoma County, California (Signature)

COE contact/individual responsible for completing this section:

Name: Shelley Stiles Title: Director, External Fiscal Services Phone: 707-542-2635 E-mail: sstiles@scoe.org

Gravenstein Union School District 2018-19 SCHOOL YEAR CALENDAR

Board Approved:

Month Year	S	M	T	W	Th	F	S	 Reports Sent Home  End of Trimester Report Period	Days of Instr	Certificated Employee Workdays
JUL 2018	1	2	3	4	5	6	7	July 4 Independence Day Holiday		
	8	9	10	11	12	13	14			
	15	16	17	18	19	20	21			
	22	23	24	25	26	27	28			
	29	30	31							
AUG	5	6	7	8	9	10	11	Aug. 13 Teacher work day Aug. 14 Teacher work day Aug. 15 First Day of School	13	15
	12	13	14	15	16	17	18			
	19	20	21	22	23	24	25			
	26	27	28	29	30	31				
SEPT	2	3	4	5	6	7	8	Sept. 3 Labor Day Holiday - No School Sept. 10 Local Holiday (Rosh Hashanah) - No School Sept. 13 Early Release Day Sept. 27 Early Release Day/Day 30	18	18
	9	10	11	12	13	14	15			
	16	17	18	19	20	21	22			
	23	24	25	26	27	28	29			
	30									
OCT	1	2	3	4	5	6		Oct. 5 No School for Students - Parent Conferences Progress Reports Given at Conference Oct. 11 Early Release Day Oct. 25 Early Release Day	22	23
	7	8	9	10	11	12	13			
	14	15	16	17	18	19	20			
	21	22	23	24	25	26	27			
	28	29	30	31						
NOV	4	5	6	7	8	9	10	Nov. 8 59th day of school - End of 1st Trimester Nov. 12 Veterans' Day Holiday - No School Nov. 20 1st Trimester Report Cards Sent Home Nov. 21-23 Thanksgiving Break - No School	18	18
	11	12	13	14	15	16	17			
	18	19	20	21	22	23	24			
	25	26	27	28	29	30				
DEC	2	3	4	5	6	7	8	Dec. 13 Early Release Day Dec. 24 - Jan. 4 Winter Break - No School	15	15
	9	10	11	12	13	14	15			
	16	17	18	19	20	21	22			
	23	24	25	26	27	28	29			
	30	31								
JAN 2019	6	7	8	9	10	11	12	Jan. 7 School Resumes Jan. 10 2nd Trimester Progress Reports Sent Home Jan. 10 Early Release Day/Day 90 Jan. 21 Martin Luther King Holiday - No School Jan. 24 Early Release Day	18	18
	13	14	15	16	17	18	19			
	20	21	22	23	24	25	26			
	27	28	29	30	31					
FEB	3	4	5	6	7	8	9	Feb. 7 Early Release Day Feb. 11 Lincoln's Day Observed - No School Feb. 18 President's Day Observed - No School Feb. 21 Early Release Day Feb. 25 Day 119 & End of 2nd Trimester	18	18
	10	11	12	13	14	15	16			
	17	18	19	20	21	22	23			
	24	25	26	27	28					
MAR	3	4	5	6	7	8	9	Mar. 6 2nd Trimester Report Cards Sent Home Mar. 7 Early Release Day Mar. 18-22 Spring Break - No School	16	16
	10	11	12	13	14	15	16			
	17	18	19	20	21	22	23			
	24	25	26	27	28	29	30			
	31									
APR	1	2	3	4	5	6		Apr. 11 Early Release Day Apr. 11 150th day of school Apr. 16 3rd Trimester Progress Reports Sent Home Apr. 19 & 22 Local Holiday (Easter) - No School Apr. 25 Early Release Day	20	20
	7	8	9	10	11	12	13			
	14	15	16	17	18	19	20			
	21	22	23	24	25	26	27			
	28	29	30							
MAY	5	6	7	8	9	10	11	May 9 Early Release Day May 27 Memorial Day Holiday - No School May 29 Early Release Day May 30 Minimum Day May 31 Minimum Day Last day of school 3rd Trimester Report Cards Sent Home	22	22
	12	13	14	15	16	17	18			
	19	20	21	22	23	24	25			
	26	27	28	29	30	31				
JUNE	2	3	4	5	6	7	8		0	0
	9	10	11	12	13	14	15			
	16	17	18	19	20	21	22			
	23	24	25	26	27	28	29			
	30									
							180	183		

Board Approved 5/9/18

Sebastopol, California, United St...



US EPA PM2.5 AQI

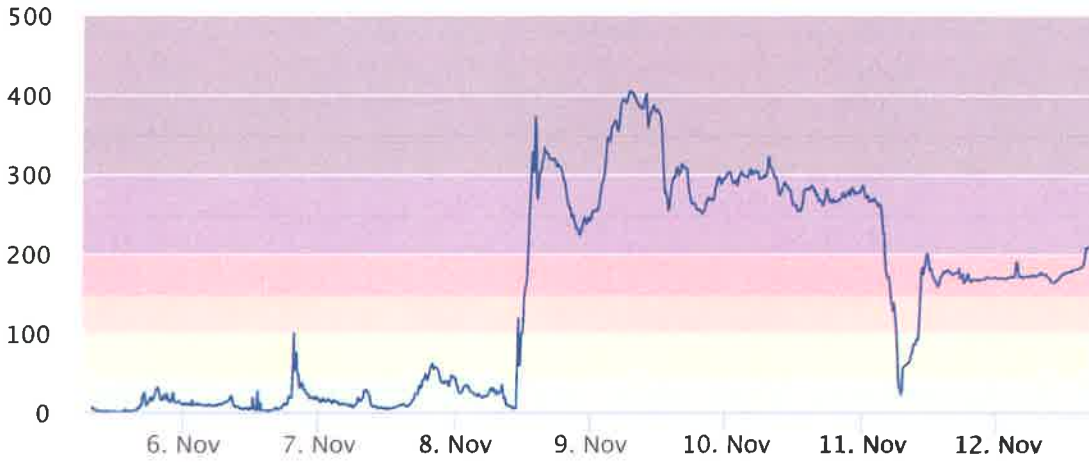

— Sebastopol A (downgraded) — Sebastopol B

PurpleAir.com

On November 12th, 2018, 4:

Real time US EPA PM2.5 AQI is now 211

201-300: Health warnings of conditions. The entire population likely to be affected.

Now	10 Min	30 Min	1 hr	6 hr
211	206	197	190	177

Sensor: Sebastopol B

PA-II 2.80e RSSI: -73

Map Data Layer: ?
US EPA PM2.5 AQI

Conversion: ? X
None

n/a | 0 | 50 | 100 | 150 | 200 | 250 | 300 | 350 | 400 | 500+

Outside Sensors Inside Sensors Show My Sensors Show Rings (Averages)

Accept Cookies Customise Cookies

Cookie Consent | © MapTiler (https://www.maptiler.com/license/maps/) © OpenStreetMap contributors (https://www.openstreetmap.org/copyright)

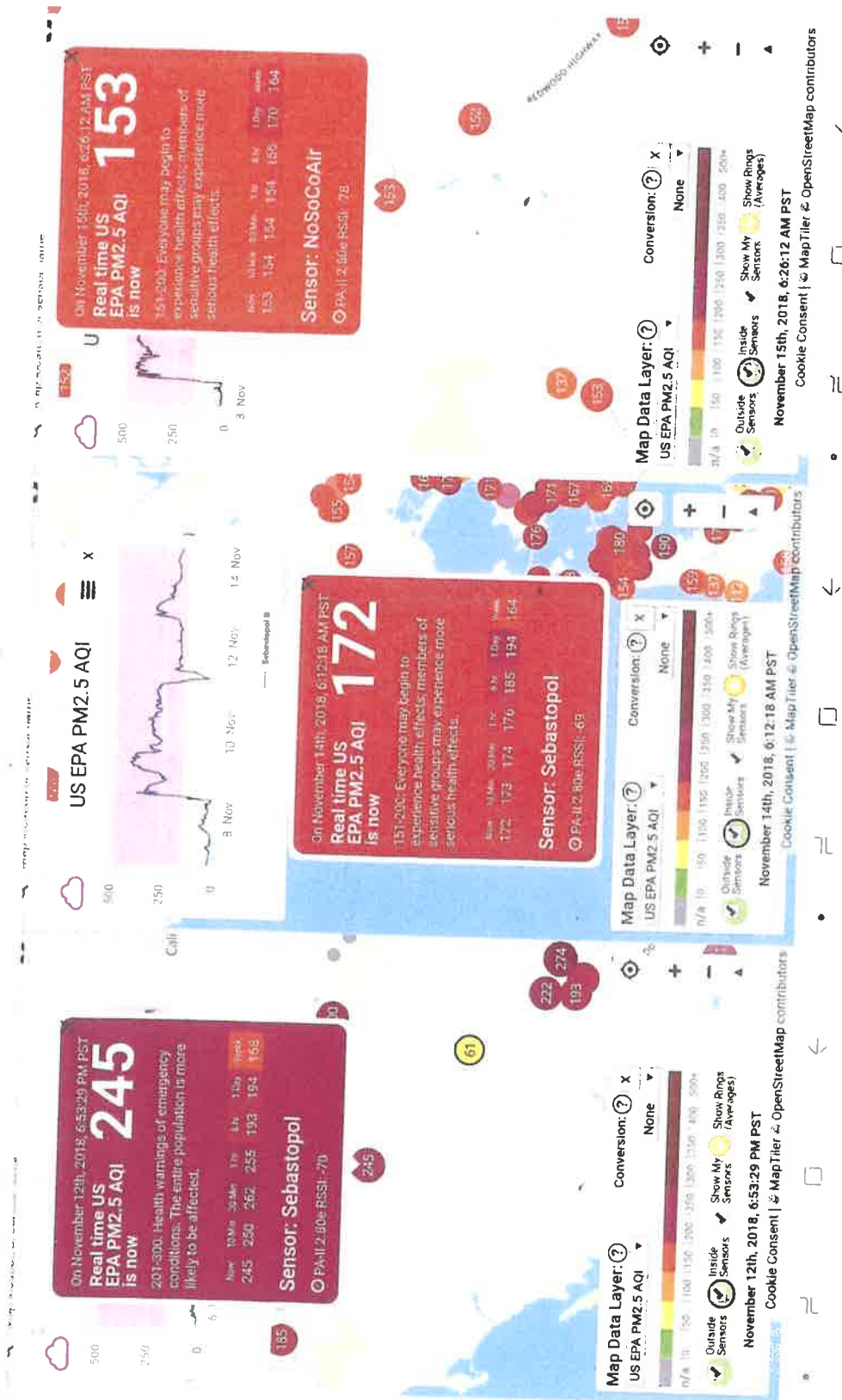



Wanda Holden <wholden@grav.k12.ca.us>

Fwd: State Confirms Funding Will Continue for Schools Closed Because of Poor Air Quality

3 messages

Jim Horn <jhorn@grav.k12.ca.us>

Fri, Nov 16, 2018 at 6:03 PM

To: Jennifer Schwinn <jschwinn@grav.k12.ca.us>, Gregory Appling <gappling@grav.k12.ca.us>, Alex Kahn <akahn@grav.k12.ca.us>, Jennifer Koelemeijer <jkoelemeijer@grav.k12.ca.us>, Steve Schwartz <sschwartz@grav.k12.ca.us>, Wanda Holden <wholden@grav.k12.ca.us>

FYI...

Jim Horn

----- Forwarded message -----

From: CSBA <csba@csba.org>

Date: Fri, Nov 16, 2018, 5:42 PM

Subject: State Confirms Funding Will Continue for Schools Closed Because of Poor Air Quality

To: <jhorn@grav.k12.ca.us>

Trouble viewing this email? [Click here »](#)

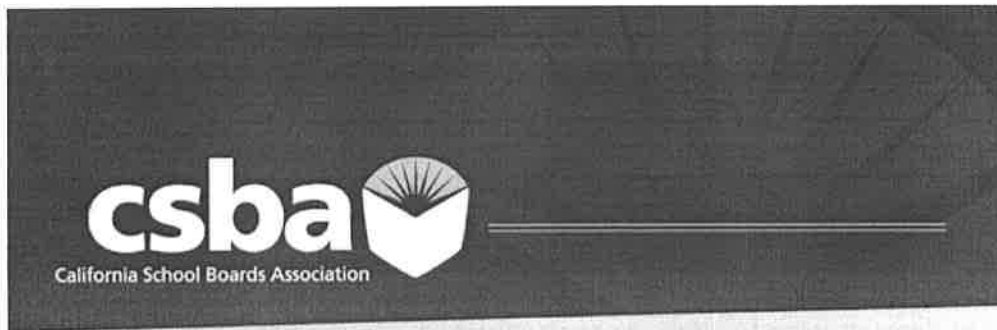

State Confirms Funding Will Continue for Schools Closed Because of Poor Air Quality

On Friday afternoon, State Superintendent of Public Instruction Tom Torlakson confirmed that LEAs which have closed schools because of hazardous air quality will not lose funding due to lower attendance -- as long as they complete a waiver application. Torlakson also promised that administrators from the California Department of Education (CDE) would be available to assist in the application process.

Please see CDE's official release below for more details and refer to this **CSBA resource for information on assisting California's wildfire victims.**



CALIFORNIA DEPARTMENT OF EDUCATION

NEWS RELEASE

TOM TORLAKSON
State Superintendent
of Public Instruction

REL#18-75
FOR IMMEDIATE RELEASE
November, 16 2018

CONTACT: Jonathan Mendick
PHONE: 916-319-0818
E-MAIL: jmendick@cde.ca.gov

State Schools Chief Tom Torlakson Assures Schools Closed Due to Hazardous Air Quality that State Funding Will Continue

SACRAMENTO— State Superintendent of Public Instruction Tom Torlakson today reminded educators who close schools because of dangerous air quality that they can apply for a waiver to ensure they do not lose funding because of a drop in attendance. He also pledged that they would be assisted by administrators from the California Department of Education.

State law allows schools to continue to receive state funds from the Local Control Funding Formula (LCFF) if they have to close because of a natural disaster such as floods, fires, earthquakes or other extraordinary conditions, such as hazardous air quality

The California Department of Education does not keep precise numbers of school closings, but schools are closed in 22 counties.

"The tragic wildfires in California that have caused so much heartbreaking destruction and loss of life are continuing to harm some of our schools and communities," Torlakson said. "I want to thank school districts for acting to protect educators and students, and to let them know that the California Department of Education will assist them in any way that we can. Safety must come first for students, teachers, and staff."

Torlakson also encouraged schools facing poor air quality to keep students indoors during recess and meals. Air quality information is available at the [AirNow website](#), and wildfire information is available from the [CAL FIRE website](#).

Approval of school closures and material decrease in attendance may be requested by submitting a **Form J-13A**. For more guidance on the J-13A submittal and approval process, see the [CDE's Form J-13A web page](#). More information about recovery resources is available from the [CDE's School Disaster Recovery web page](#), and at this [CalOES web page](#). Find more information regarding health and the effects of smoke and ash at the [CalEPA website](#). Any impacted school or local education agency can contact EmergencyServices@cde.ca.gov to connect with the CDE team.

Counties where one or more schools are closed:

Alameda County
Butte County
Colusa County
Contra Costa County
Glenn County
Lake County
Los Angeles County
Marin County
Napa County
Nevada County
Placer County
Solano County
Sonoma County
Sacramento County
San Francisco County
San Joaquin County

San Mateo County
Santa Clara County
Sutter County
Ventura County
Yolo County
Yuba County

Please contact your local school, district or county for the latest closure information.

#####

The California Department of Education is a state agency led by State Superintendent of Public Instruction Tom Torlakson. For more information, please visit the **California Department of Education's** Web site or by **mobile device**. You may also follow Superintendent Torlakson on **Twitter**, **Facebook**, and **YouTube**.



California School Boards Association | 3251 Beacon Blvd., West Sacramento, CA 95691

Phone: (800) 266-3382 | Fax: (916) 371-3407

[Website](#) | [Privacy Policy](#) | [Unsubscribe](#)

Wanda Holden <wholden@grav.k12.ca.us>
To: Jim Horn <jhorn@grav.k12.ca.us>

Fri, Nov 16, 2018 at 6:08 PM

Thanks Jim,
Definitely good news!
[Quoted text hidden]

Wanda Holden <wholden@grav.k12.ca.us>
To: Wanda Holden <wholden@grav.k12.ca.us>

Fri, Dec 7, 2018 at 4:08 AM

[Quoted text hidden]



GUSD schools closed Tues - due to air quality

1 message

Jennifer Schwinn <jschwinn@grav.k12.ca.us>

Mon, Nov 12, 2018 at 7:24 PM

To: Alexander Kahn <akahn@grav.k12.ca.us>, Gregory Appling <gappling@grav.k12.ca.us>, Jennifer Koelemeijer <jkoelemeijer@grav.k12.ca.us>, Jim Horn <jhorn@grav.k12.ca.us>, Steve Schwartz <sschwartz@grav.k12.ca.us>, William Deeths <wdeeths@grav.k12.ca.us>, Keri Pugno <kpugno@grav.k12.ca.us>, Otterson-Trivunovic <gravensteinguta@gmail.com>, gravteachers@grav.k12.ca.us, gravstaff@grav.k12.ca.us, hillteachers@grav.k12.ca.us, hillstaff@grav.k12.ca.us

Hello All,

I have been closely monitoring the air quality today. It has been in the hazardous range all day, and it has gotten worse this evening -- between 250 and 290.

I was at Gravenstein today, and found the heating system running in the office and in 80% of classrooms. We went around and manually shut them off in each room. If you go to campus, please do not activate heat or cooling systems. Do not even run HVAC in fan mode because commercial HVAC systems draw in outside air, and we are trying to clean the classrooms before bringing students back. Keep doors and windows closed as well.

Brian is changing all the filters, and then we want to run them once the air hits the yellow zone, or under 100, to clear any smokey air from the buildings and classrooms.

We also want to wash surfaces (picnic tables, benches, play structures, walkways, etc) once the ash stops falling, in preparation of students returning.

The problem is that the wildfires are not under control yet, and so the conditions persist that are causing this toxic air to sit in our County.

I know that closing school is a difficult decision to make. It impacts families and especially students, who miss instruction. However, what I have learned about the effects of wildfire smoke on children over the last few days has made me cautious about requiring families to leave the safest location, their home under these conditions.

If you want to learn more about the effects of wildfire smoke on children and what goes into deciding whether to close school, please take a minute to check out the resources that I included in my most recent Monday Message over the weekend.

Stay tuned for updates via email. A message from our Schoolwise system is about to go out to families, but I wanted you to know first what to expect tomorrow, and what I am thinking about how to safely return to school during these fires. I hope this closure allows you and your own children to stay home where they are most safe under current conditions. No staff should report to school on Tuesday, Nov 13.

Take care,
Jennifer

--
Jennifer Schwinn
Superintendent

Gravenstein Union School District
3840 Twig Ave.
Sebastopol, CA 95472
(707) 823-7008



GRAVENSTEIN UNION SCHOOL DISTRICT

AN AWARD WINNING K-8 DISTRICT IN
SEBASTOPOL, CA

Upcoming Activities

GUSD Board Mtg
Nov 14, 2018
5:00pm
Gravenstein Rm 13

Find a complete list of
District activities on the
GUSD Master Calendar at
www.grav.k12.ca.us/Calendar

At this time, the 11-14-18
GUSD Board meeting will
occur as scheduled.

GUSD Schools Closed, Wed, Nov 14



GUSD Schools Closed Wednesday, Nov 14, 2018 Due to poor air quality

If you want to learn more about the effects of wildfire smoke on children and what goes into deciding whether to close school, please take a minute to check out the resources that I included in my most recent Monday Message over the weekend.

Here they are again, in case you missed them:

SCOE advisory on air quality
Protecting children from wildfire smoke

Air Quality Still Unhealthy

Dear GUSD Families:

I have been closely monitoring the air quality today. It has been in the unhealthy range all day, and it has gotten worse this evening -- AQI 181 See "Purple Air" for on-going, local air quality readings.

Given current conditions it seems that the safest decision for our students and staff is to cancel school for tomorrow, Wednesday, Nov 14.

Brian Sposato (our Head of Facilities) and I have developed the following plan to bring students back:

- Currently all HVAC systems are off, so no unhealthy outside air is pumping into the classrooms.
- He is swapping all the filters with MERV 13 rated filters. That is out of a rating from 1-16, so 13 is a high quality filter to clean the air.
- Once the air is out of the "unhealthy" range, we will run the systems and clear the air inside buildings.
- Kevin and Brian are also washing down outside surfaces to clear them of ash. That way students are not tracking the ash into the classrooms, or sitting at picnic tables

Today, SCOE has provided the following chart to help guide school closures:

Sonoma County Air Quality Guidelines

However, I confirmed that it is still a local decision whether a District closes. I have advocated that we follow the guidelines set by Napa County Office of Education, where schools close when air quality is in the "unhealthy" range. I feel that is a safer guideline for students and staff, and better follows the advisory from the EPA and Pediatrics Association above. Here are Napa's guidelines:

Napa County Air Quality Guidelines

that are covered with that chemical debris.

I want to thank Board President, Jim Horn, and the rest of the GUSD Board for their support. I did not feel that it was right to open school in these conditions. It is a hard choice to close school. We take the decision seriously. By making the decision tonight, we allow folks to plan. Other Districts may not close, or may not decide to close until tomorrow morning. Some are using 275 AQI as the limit that determines closure. However, once we hit AQI 200 the rating is described as "health warning of emergency conditions." So I do not feel comfortable using "under AQI 275" as the guide to stay open.

I am confident in the decision to close Wednesday. Even if it means we have to add a day later, (and that is still unlikely) I would rather add a day when the air is good than under these conditions. I hope that we can resume school on Thursday, but air quality conditions are hard to predict. So stay tuned... and stay safe.

Take care,
Jennifer Schwinn
Superintendent
GUSD



If you have any questions or comments, please reply to this message.

Jennifer Schwinn
Superintendent
Gravenstein Union School District
Email: jschwinn@grav.k12.ca.us
phone: 707-823-7008

[WEBSITE](#)

[ABOUT US](#)

[MENUS](#)

[SCHEDULES](#)

[Elementary School Website](#)

[Middle School Website](#)

[Creative Arts Program](#)



GRAVENSTEIN UNION SCHOOL DISTRICT

AN AWARD WINNING K-8 DISTRICT IN SEBASTOPOL, CA

Upcoming Activities

Find a complete list of District activities on the GUSD Master Calendar at www.grav.k12.ca.us/Calendar

GUSD Schools Open, Thursday, Nov 15

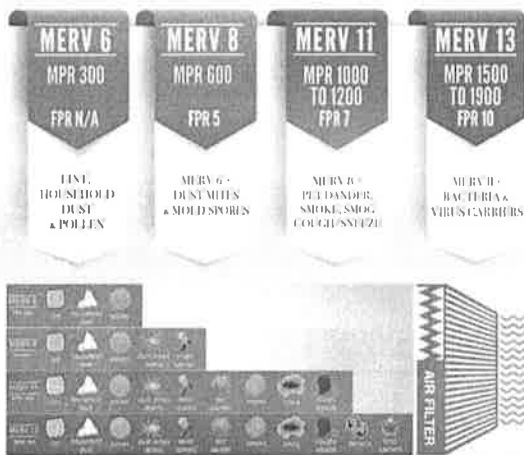

Safety Protocols in Place

Dear GUSD Families:
Sorry to get this to you a little late. We had a Board meeting tonight.

I have been closely monitoring the air quality again today. The local Air Quality Index (AQI) has finally started to drop below AQI 150. That along with protocols that have been put in place on GUSD campuses, have led to my determination that it is reasonable to resume school on Thursday. (See "Purple Air" for on-going, local air quality readings.)

Of course parents of children with specific health concerns will need to make the best choice for their own child, and follow the advice of their doctor.

To help you feel confident in your decision to send your child to school please review the steps that we have taken to protect their health.

Brian Sposato (our Head of Facilities) and I have developed the following plan to bring students back:

-All HVAC systems were kept off while AQI was high, so no unhealthy outside air

GUSD Schools Open Thursday, Nov 15, 2018

Resources:

Over the last few days I have learned a lot about air quality; commercial HVAC systems, and more. I used this information to guide my decision making.

If you want to learn more about MERV ratings of filters, check out the illustration above.

We installed MERV 13 filters across the District. They screen out the sub-micron particles that are in wildfire smoke.

I also shared some documents that

influenced my decision making. Here they are again, in case you missed them:

SCOE advisory on air quality
Protecting children from wildfire smoke

SCOE has provided the following chart to help guide school closures:

Sonoma County Air Quality Guidelines

However, those were just recommendations and SCOE assured me that whether our district is open or closed is a local decision. We had considerations like a gym under construction that impacted our district.

I have good news on that front too!

The Gravenstein gym is just about finished, and therefore, we are able to access it before school so **students are to report to the gym before school, rather than waiting in the courtyard.**

At Hillcrest, students should also report to the gym before school.

We will have students inside all day, for recess, lunch, PE, with limited exposure to outside air.

was pumping into the classrooms.

-Brian swapped all filters in classrooms and other buildings with MERV 13 rated filters. (That is out of a rating from 1-16. MERV 13 is rated for filtering sub-micron particles from the air.)

-He also vacuumed the ducts in each room.

-Now that air is improving we are running the systems to clear the air inside buildings.

-Kevin and Brian power washed outside surfaces. That way ash is not tracked into the classrooms.

- They cleaned inside classrooms too.

It takes a village, and that is never more true than when times are difficult.

So let me say...

A BIG thank you to Brian and Kevin for all their hard work!

I want to thank Board President, Jim Horn, and the rest of the GUSD Board for their support of closing school until I felt we could resume safely.

Thank you to all the parents who managed the challenges of missing work, being home and cooped up with the kids inside while we completed our preparations to welcome them back safely.

I am confident in the decision to resume school given the steps we have taken. I now feel that we can offer superior air filtration that is as good or better than home. Procedures are in place to keep students inside with minimal time exposure to outside air during the day, while the AQI continues to drop.

I will continue to monitor AQI, and will notify you asap if AQI rises unexpectedly, but with our filters we can manage some levels of unhealthy air, though you will certainly get a call from me if we near 200 again. Though that is unlikely at given current trends.

Take care,
Jennifer Schwinn
Superintendent
GUSD





TREND SHOWS AQI MOVING OUT OF THE RED ZONE

If you have any questions or comments, please reply to this message.

Jennifer Schwinn
 Superintendent
 Gravenstein Union School District
 Email: jschwinn@grav.k12.ca.us
 phone: 707-823-7008

[WEBSITE](#)

[ABOUT US](#)

[MENUS](#)

[SCHEDULES](#)

[Elementary School Website](#)

[Middle School Website](#)

[Creative Arts Program](#)



California Distinguished Schools!

[Contact Us](#)





**GRAVENSTEIN UNION
SCHOOL DISTRICT**
AN AWARD WINNING K-8 DISTRICT IN
SEBASTOPOL, CA

Upcoming Activities

Special Board Mtg
Fri, Nov 16
12:30pm
At District Office
Closed session only
for student discipline

Find a complete list of
District activities on the
GUSD Master Calendar at
www.grav.k12.ca.us/Calendar

GSF's Skate Night
Still On!
Fri, Nov 16
5:30-7:30pm
Cal Skate of
Rohnert Park

GUSD Schools Closed, Friday, Nov 16

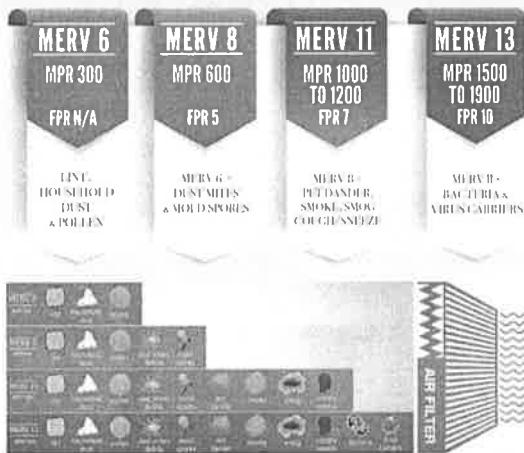

Air Quality Index in 200's

Dear GUSD Families:

Wow! The Air Quality really took a turn for the worse since this afternoon! I was hoping we were steadily improving. However, I have been closely monitoring the air quality again today. Very unhealthy air seems to be sitting from the SF Bay Area to South Sonoma County. Sebastopol is even worse than Santa Rosa. We look more like the numbers coming from South County. We have been in the 200's for hours (even up to 215).

I was able to find a forecast for tomorrow's air quality, and it is predicted to be worse tomorrow.

<http://tools.airfire.org/outlooks/RegionalNorth-CentralCalifornia>

I wanted to let you know tonight so you can plan for the school closure. Thank you, Parents, for your on-going understanding and flexibility under these conditions.

On a positive note, we had a great day back at school today. The filters really made a difference! The air in the rooms was so

**GUSD Schools Open
Thursday, Nov 15, 2018**

Resources:

Over the last few days I have learned a lot about air quality; commercial HVAC systems, and more. I used this information to guide my decision making.

See "Purple Air" for on-going, local air quality readings.

If you want to learn more about MERV ratings of filters, check out the illustration above.

We installed MERV 13 filters across the

District. They screen out the sub-micron particles that are in wildfire smoke.

I also shared some documents that influenced my decision making. Here they are again, in case you missed them:

SCOE advisory on air quality
Protecting children from wildfire smoke

SCOE has provided the following chart to help guide school closures:

Sonoma County Air Quality Guidelines

However, those were just recommendations and SCOE assured me that whether our district is open or closed is a local decision.

By the way, some Sonoma County Superintendents are now talking about adjusting that 275 AQI threshold down to 200 for school closures. The voices of parents were heard loud and clear throughout the County and especially on SCOE's Facebook page.



AQI LEVELS NOW OVER 200

good!

Of course, we kept the students inside all day. I did inside lunch duty today, and the filters even managed to clear the food smells out of the rooms. The MERV 13 filters made a dramatic change!

If we had been even around 170 AQI, I would have considered staying open because we have such good protocols and filters in place. We can offer a safe environment when students are inside. However, at 200 AQI, even though I was very pleased with the air quality in our classrooms today with those new filters, this just seems too unhealthy for folks to travel around, driving to and from school, and I don't like the incidental exposure that being at school will cause when conditions outside are this bad and predicted to worsen.

Thanks once again to Board President, Jim Horn and the GUSD Board for their support of closing school, for the safety of our school community.

I hope you can stay inside, safe from this unhealthy air. It is forecast to be bad for a couple days.

GUSD is currently scheduled to be open next week on Monday and Tuesday. I will keep in touch if very unhealthy air (200AQI or more) persists into next week.

Take care,
Jennifer Schwinn
Superintendent
GUSD

If you have any questions or comments, please reply to this message.

Jennifer Schwinn
Superintendent
Gravenstein Union School District



GRAVENSTEIN UNION SCHOOL DISTRICT

AN AWARD WINNING K-8 DISTRICT IN
SEBASTOPOL, CA

Upcoming Activities

Tues, Nov 20
Trimester 1 Ends
Report Cards Sent Home

Find a complete list of
District activities on the
GUSD Master Calendar at
www.grav.k12.ca.us/Calendar

Wed Nov 21 - Fri Nov 23
Thanksgiving Break
NO SCHOOL

GUSD Schools Expected in Session

Mon, Nov 19 & Tues, Nov 20

For now, school is expected to be open Monday, Nov, 19 and Tuesday, Nov 20, as scheduled on the adopted 2018-19 GUSD calendar.

We are monitoring air quality, and if local conditions worsen, school may be closed. However, current conditions are in the range that our upgraded air filtration system can handle. Today, AQI in Sebastopol is in the 150s.

So unless AQI veers up into the 200's, you can expect school to be open. At the last GUSD Board meeting the Trustees and I discussed our District using 200 AQI as our threshold for school closure, given our new upgrades.



We have taken the following safety precautions:

- Installed **MERV 13 filters** -- which filter sub-micron particles in smoke
- We have updated **HVAV systems** -- installed in the last 5 years
- Daily procedures in place to keep students inside filtered buildings throughout the day
- Alternate low-exertion activities in place of outdoor recess or PE

Given these measures, air quality at school is likely to be as good as or better than in

homes. Therefore, we feel comfortable staying open for school when under AQI 200.

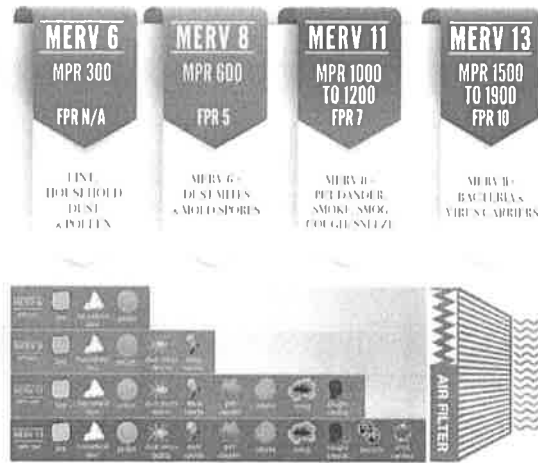

Why is GUSD Open Next Week?

Other Districts are Closed for the Week

The annual GUSD calendar is a negotiated item between the District administration and GUTA (the teachers' union) before it goes to the GUSD Board for approval. In the last few years, Sonoma County Schools have made an effort to align to the same calendar to allow families who live, work, and learn in different Districts to have the same schedule.



Calendars are designed to meet the needs of the community they serve. For example, in some communities a "ski week" is popular in February, but that is not typical in this region. Gravenstein USD has long followed a traditional calendar with a shorter Thanksgiving Break, and time off near Easter.

A number of factors went into the decision to have Thanksgiving Break from Wed – Fri, when the majority of Sonoma County Districts take the entire week off from school. If you are curious to know more about the process, read on.

Calendar Planning for 2019-20

We would like to know if GUSD families have a strong opinion on whether to have a full week off at Thanksgiving or to have a shorter Thanksgiving Break to borrow two days off to place elsewhere on the calendar, such as next to Easter, or in long months without holiday breaks.

We will create a survey to get stakeholder input, that will help guide the 2019-20 calendar. Watch this space for a survey coming soon.

In the meantime, school is open at Gravenstein and Hillcrest this Monday and Tuesday before closing for Thanksgiving

- The District administration advocated for aligning with the Sonoma County common calendar.
- GUTA preferred a shorter Thanksgiving Break, because it allowed for a day off next to Easter Sunday, now that Spring Break no longer aligns to Easter.
- GUTA also liked the idea of a day off in the long month of April.
- The District suggested the other day captured from the shortened Thanksgiving Break could be used for a three day weekend in September that fell on the Jewish holiday Rosh Hashanah.
- It was also considered that some families would prefer to have the week off to travel in order to be with extended family for the holiday, but the Independent Study Contracts would allow those families to be

Sonoma County Office of Education establishes guidelines for school closures on smoky days

SUSAN MINICHELLO

THE PRESS DEMOCRAT | November 13, 2018



[Follow this story](#)

Public school districts across Sonoma County have new guidelines to help them determine when to close schools on smoky days, following several days of polluted skies from the Camp fire over 100 miles away in Butte County.

The Sonoma County Office of Education established the general rules on Tuesday advising districts to base decisions on school closures on local air quality levels measured by the U.S. Environmental Protection Agency's Air Quality Index. District officials should view the air quality index at purpleair.com at 5 a.m. the day school closures are being considered and are recommended to cancel classes when the index shows air quality at a "very unhealthy" level of 275 or higher.

As of early Wednesday, the only school districts closed were Gravenstein Union in Sebastopol and River Montessori in Petaluma, according to the Sonoma County Office of Education.

Several parents reacted with swift criticism to the county office's measurement recommendation, saying it's a health risk for students to attend schools when air quality levels are as poor as the 275 threshold.

"Generally, we believe that students are in a safer air environment when they are in school. This is because schools typically use filtered air while many homes may not have this ability," County Superintendent Steve Herrington said Tuesday evening in a statement.

The EPA air quality levels range from zero to 500. The 201 to 300 level is considered "very unhealthy," while a reading from 300 to 500 is air that's considered "hazardous" and can cause serious health effects to residents. By comparison, air quality levels from zero to 100 are considered satisfactory or acceptable with no or little health risks.

Late Tuesday night, the air quality readings for the county ranged from a low of 129 in Rohnert Park to a high of 182 in Sebastopol. On Thursday when smoke from the Camp fire in the Chico area blew south into Sonoma County, air quality levels soared to over 400 in certain areas. The air quality has improved since then but remained at unhealthy or very unhealthy levels from Friday through early Tuesday.

We use cookies to optimize your experience, analyze traffic, and personalize content. To learn more, please visit our [Privacy Policy](#). By using our site without disabling cookies, you consent to our use of them.

Accept

55

consultation with the county health director, along with guidance from the Centers for Disease Control and Prevention “with the understanding that air quality tends to worsen as the day progresses.”

All 40 school districts in Sonoma County closed Friday because of hazardous air quality. Schools remained closed on Monday for Veterans Day, and nearly all county districts closed again on Tuesday due to poor air quality.

“At first we thought it was an anomaly, but we decided to set a countywide protocol today (Tuesday),” Herrington said.

Concerned for the health of their children, many parents said they vehemently opposed reopening schools when the air quality is near the 275 level.

Barbara Ruch, 48, whose 12-year-old has asthma and attends school in the Cotati- Rohnert Park district, said she thinks schools should close if air quality surpasses the 150 level.

A 151 to 200 air quality reading is considered “unhealthy” and the new county guidelines recommend schools stay open under these air conditions.

“If it’s unhealthy, I’m not sending her to school,” Ruch said. “It’s ridiculous. I don’t even have words for it. I don’t see how they can see that as responsible.”

Rigel Bowen, 39, has two children, including an 11-year-old who attends Twin Hills Charter Middle School in Sebastopol.

Bowen said his children also won’t be going to school when air quality is above 150 and they won’t participate in physical education class if the level is at 100 or higher. Schools superintendents from across the county gathered with Herrington Tuesday to discuss air quality guidelines for school closures at the suggestion of Santa Rosa City Schools Superintendent Diann Kitamura.

“Unfortunately, we might have to make these decisions more going forward,” said Jenni Klose, president of the Santa Rosa School Board.

After spending Veterans Day monitoring air quality, 34 of the county’s 40 school districts announced by 10 p.m. Monday that schools would be closed on Tuesday. The 5 a.m. time for districts to check air quality before deciding whether to close that day was decided because data would be more accurate and timely then.

A handful of districts decided to wait until Tuesday morning to decide on closures. Liberty School District in Petaluma waited, and ultimately decided to keep school open on Tuesday.

"If we had made a call at 5 o'clock this morning (Tuesday) we would have had schools open today," Herrington said Tuesday afternoon. The Santa Rosa district — the county's largest with about 16,000 students — learned a lot from the October 2017 wildfires, Klose said. New air filters were installed at each school and the custodial staff has experience cleaning schools affected by polluted air. Meanwhile, Santa Rosa Junior College, which closed on Tuesday, will make an announcement around 6 a.m. today regarding Wednesday classes, spokeswoman Erin Bricker said.

Sonoma State University was one of a small group of countywide academic institutions having classes as usual on Tuesday. About 75 to 100 students walked out of classes at 11:30 a.m. Tuesday to protest university leaders' decision to open despite unhealthy air quality, said Jason Gorelick, a 20-year-old sociology student. Gorelick admitted it was ironic to protest the conditions by walking outside in the smoky air. He said students and faculty weren't consulted before administrators decided to hold classes Tuesday.

"This is just as much about the health and safety of students and faculty as it is about the principle of collective decision and shared governance," Gorelick said.

SSU spokesman Paul Gullixson said the decision to remain open was made by President Judy Sakaki and her cabinet. The decision took into consideration local air quality readings, weather forecasts, wind direction and the university's effective air filtration system in campus buildings.

A winter Spare the Air alert banning wood burning will remain in place in the county through Friday, with poor air quality remaining a public health concern in the North Bay, said Kristine Roselius, a spokeswoman for the Bay Area Air Quality Management District.

Nighttime temperature inversions will trap the lingering smoke close to the ground "like a Tupperware lid," she said.

Onshore winds may clear the air next week, but it's too soon to tell if they will arrive, Roselius said.

Staff Writer Guy Kovner contributed to this report.

GUSD would like you to consider and discuss the following two program proposals for 2019-20:

Hillcrest

Single program for all grades beginning 19-20 school year

Includes common grade level field trips

- Field trips, both academic and social emotional, will still be an integrated part of the Hillcrest program for all students.

- A rich and varied elective program incorporated into the regular school day for all students. Current enrichments will be converted to electives

Leveled academics in ELA and Math

- Opportunities to work at accelerated pace for those who need it, and the ability to offer support for struggling students

During these initial discussions, this proposal is what the majority of the staff and administration feel will best support the entire Hillcrest school community.

What are the thoughts and/or concerns you have for your student, if Hillcrest moves forward with this plan?

Gravenstein

Academically accelerated charter school-wide for all grades beginning in 19-20

- Single program for all students
- Promote academic excellence for all students
- Provide appropriate challenge & support for all levels of students including:
 - GATE
 - Accelerated students
 - Students with special needs
 - Students performing below grade level

Field Trips

- Integrated and supported by curriculum
- Common grade level field trips (still OK for individual teachers to have special, unique field trips)

Enrichment opportunities offered for all, consistent at each grade level

- Engaging and varied enrichment program incorporated throughout the regular day
- Support for academic remediation offered at same time as enrichments

What are the thoughts and/or concerns you have for your student, if Gravenstein moves forward with this plan?



GUSD Board of Trustees Listening Session

11/7/18

On November 7, the GUSD Board of Trustees held a public Listening Session at Hillcrest Hall to hear comments and feedback on two ideas proposed for future programming.

- 1) Hillcrest Topic**
- 2) Gravenstein Topic**

This summative report contains history and background on the process and the summarized notes from the 11/7/18 discussions.

Superintendent Schwinn opened the Board's Listening Session on Nov 7, 2018. She described goals and an agenda for the session. Two concepts were presented for discussion. (Please see appendix for specific proposals.)

Superintendent Schwinn also provided a recap of inquiry and actions taken since 2016-17, with regard to the District's dual program system.

Where We Have Been: Summary of Process, Decisions, and Changes to Date

2015-16:

- Superintendent LaMarre was retiring and a headhunter firm was selected to hire a new Superintendent.
- As part of the process, stakeholder meetings were held and feedback collected, which identified a concern among parents and staff around the dual program system and how it was affecting school culture and equity among students and staff.

2016-17:

- The summer of 2016, Supt. Schwinn discussed the headhunter's stakeholder feedback with the Board and shared an opportunity to explore the dual program arrangement via a year-long program at SCOE in 2016-17.
- SCOE arranged for Michael Fullen to work with school teams on "system cohesion."
- Board approved a GUSD Leadership Team of teachers and administrators to participate in the SCOE Systems Cohesion workshops, and look at the dual program system in a "year of inquiry" throughout 2016-17.
- We held a District-wide meeting with staff 12/6/16 to discuss the dual program system (staff feedback in 11-7-18 resource packet on the District website under "Board agendas")
- GUSD held two Town Hall meetings with stakeholders
- Staff asked for a demographic study of participation in each program.
- Demographic study was conducted by Leadership team and presented to Board in 2017.

- Art enrichment was increased for Traditional classes.
- Opportunities for pilot programs identified by Leadership team in kindergarten and 6th grade.

2017-18:

- Leadership Team grew to a Stakeholder Committee to study Dual Program -including parent representatives of GSF (Gravenstein Schools Foundation) and MPF (Magnet Program Foundation), GUSD Board of Trustees, teachers, and administration.
 - Survey of Parents conducted by Stakeholder Cmte (results in 11-7-18 resource packet)
 - Survey of staff conducted by Stakeholder Cmte (results in 11-7-18 resource packet)
- 1-3 common grade level field trips that year was the goal set, and many grade level teams exceeded expectations by having all students in a grade level participate in the same field trips all year long, representing significant expansion of opportunities for Traditional students
 - Art with Nanci Ricciardi was increased further for Traditional students
 - PE Teacher was hired for Gravenstein to provide engaging physical education for all 1-5th graders.
- Board committee was formed to establish reserves to support enrichments and program expansion for 5 years, reserve strategy was approved by full Board of Trustees to mitigate potential reduction of donations to support programs. (In 11-7-18 resource packet)
 - Kindergarten Discovery pilot was planned and advertised for 2018-19
- GUSD began asking all parents for donation to expand field trip programming.
- District wide town hall meeting was held attended by over 100 stakeholders
- Smaller town hall meetings were held at each campus to gather additional input

2018-19

- Kindergarten Kick-Off
- GUSD launched Kindergarten Discovery pilot with record enrollment!
- GUSD asked parents to support Kindergarten Discovery! (in application packet)
- GUSD launched 6th grade STEAM pilot at Hillcrest
 - GUSD launched 1-5th grade Traditional pilot for 1 extra enrichment per week.
- GUSD further expanded field trips to all grades, including Traditional students participation in overnight trips like 6th grade outdoor education at Marin Headlands.
 - GUSD asked parents to contribute an activity donation to support their child's big field trips for the year.
- Administration discussed the proposals with teachers at the Nov and Dec 2018 staff meetings, to gain additional feedback.
 - GUSD Board held a Listening Session with stakeholders 11-7-18, to gain feedback on District vision planning for 2019-20.

Next steps following 11/17/18 Listening Session:

- Every comment collected via suggestion box, easel pads, and post-its was transcribed, and raw data presented to Trustees Appling and Schwartz (Listening Session sub-committee)
- Raw data available to public upon request. Please contact school Principals.

- Trustees Apppling and Schwartz directed administration on creation of this report for the Board and public, to be presented at 12/12/18 Board meeting. (Packet posted online by 12/8/18)
- Administration sent Gravenstein Teachers a Google doc to collect further feedback on programming for TK-5th grade, prior to 12/12/18 Board meeting.
- Superintendent Schwinn reminds public of the 12/12/18 Board via the Monday Message, and link the Board packet with this report to the 12/10/18 Monday Message.
- Interested stakeholders are encouraged to attend the 12/12/18 Board meeting where the Trustees will discuss the Listening Session feedback. The GUSD Board is expected to set vision for 2019-20 and beyond at either the 12/12/18 or the 1/16/19 Board meetings.



GUSD Board of Trustees Listening Session, 11/7/18

Summarized notes on discussion of one academically accelerated program for all grades at Gravenstein Elementary School, beginning in 2019-2020.

Summary of Positive Observations from Listening Session- Gravenstein Topic

Social Integration & Inclusive Community

- Proposal addresses division between two programs and brings together students, families, and staff.
- Could lead to a single parent foundation for unified purpose of benefiting all students.
- Proposal builds a stronger community

Enrichment & Field Trips

- Equalizes offerings to all students at each grade level
- Enrichments also seen as a way to enhance and strengthen academic connections, so increasing these offerings supports academics as well as increasing student engagement and enjoyment.

Academics

- The increased amount of necessary resources will benefit all students.
- Acceleration (high level of academic rigor) is sought by many parents and will continue to draw academically-focused families.

Summary of Concerns shared at Listening Session- Gravenstein Topic

Finances & Budget

- How sustainable is this without a dedicated fundraising body (MPF)?
- Will this affect the role of the parent group? Reliance upon parent group for funds?
- Additional costs: hiring and training more Instructional Aides, hiring a Primary Reading Specialist, and the district being responsible for field trips and enrichment classes (offset by unknown parent donations)

Enrichments

- Would there be availability of a significant number of quality instructors
- With increased number of classes, will current services be reduced?

Academics

- By intentionally increasing the range of levels/abilities in each class, how will it impact the teacher's ability to maintain current activities and expectations (and the student's daily experience).
- Schools that are "Accelerated" are opt-in and self-selected. This would not be the same as the proposed model. Just as there is focus on those students with academic challenges, there needs to be equal focus on those who need academic challenge.

Summary of Concerns shared at Listening Session (cont.)

Student Readiness (Social-Emotional and Developmental)

- Is the pressure to fit into an accelerated program appropriate for all students? Some students struggle with enrichment transitions, multiple teachers, rigorous pace, immaturity/developmental readiness.

Timeline

- Is it possible to recreate/rebrand program before 2019-2020?
- Is it possible to hire new staff (district employees and enrichment contractors) and create infrastructure before 2019-2020?

Summary of Questions shared at Listening Session- Gravenstein Topic

Need to Define:

- Acceleration/Accelerated: faster pace, more work, advanced level, mindset?
- Academically Accelerated School (is there a successful model to follow?)
- Academic Rigor
- Academic Remediation/Intervention (Support Systems)
- Targeted Instruction (versus Leveling or Tracking)

Staffing Questions

- Will there be teacher and staff training based on this new model?
- When will this be negotiated with GUTA?
- Which staff is helping/teaching the targeted instruction (remediation and/or acceleration)?

Enrichments & Field trips

- Can participation still be optional? Afterschool?
- Will some "big ticket" trips be cut due to low donations?

Academics

- How can a school accelerate for all?

What about:

- Gravenstein First (separate “school” requirements?)
- After school GATE?
- Learning Lab? Speech?



GUSD Board of Trustees Listening Session, 11/7/18

Summarized notes on discussion of one program for all grades at Hillcrest Middle School, beginning in 2019-2020.

Summary of Positive Observations shared at Listening Session- Hillcrest Topic

Academic Program

- Leveled classes to serve the needs of all learners
- Access to Electives for all students
- Accelerated Core class options for students

School Community

- It will create a deeper sense of community for students, staff and families

Field Trips

- Access to all trips for all students

Summary of Concerns shared at Listening Session- Hillcrest Topic

Academic Program

- How will students be placed in leveled classes?
- Will teachers have the training and professional development to teach leveled classes?
- Will the school day be longer? Is there an opt out for students who do not want 8th period?

School Community

- Will families leave without Enrich?
- Will we lose our “brand”?
- How can we keep the feeling of inclusiveness that our Enrich families currently feel?
- What will a single release time do to traffic?

Financial

- Can we sustain field trips for all?

- Without MPF who will pay for the electives, field trips, etc?

Field Trips

- Some parents share a greater burden for driving on Field Trips
- If there is only one program will the Enrich! trip to Ashland still happen or it will it have to be canceled?

Summary of Questions shared at Listening Session- Hillcrest Topic

Academic Program

- How will the integrity of leveling be maintained?
- How will electives be implemented in one program?
- How will the various academic levels be addressed?
- How will block scheduling impact learning?
- Can we create a cohort that wants longer days for extra electives?
- Can electives be at the end of the day?
- How will we measure success?
- What will the bell schedule look like?
- What are the logistics of one program for all?

Financial

- How do we encourage donations? Can we survey to see who will still donate?
- How will this affect the GUTA contract?

•Mission Statement

We, the Gravenstein Union School District, are dedicated to academic excellence and the cultivation of individual strengths and talents in a caring and cooperative environment. Our sense of community fosters a high level of ethical, responsible citizenship. State and District policies support our common goal.

•Goal #1

1. Continue to provide a rigorous academic program that supports all students in achieving their full potential.
-

Agenda 11-07-18

6:00pm Opening Remarks – Superintendent Schwinn

- Review last 2-3 years of District inquiry and actions regarding dual program system
- Review format for the evening
- How to use post-its & suggestion boxes for additional feedback

6:15pm Discuss Topic 1

- Discussion - 20 minutes (end 6:35pm)
- Report - 10 minutes (end 6:45pm)

Trustees move to a new table

6:45pm Discuss Topic 2

- Discussion – 20 minutes (end 7:05pm)
- Report – 10 minutes (end 7:15pm)

7:15pm Trustees' final thoughts (1-2 minutes each or 10 minutes max)

7:25pm Board President Horn – Closing remarks

Review next steps:

- Administrative staff compiles report of feedback from the evening
- Provide feedback report to the Board
- Make report available to the public (via www.grav.k12.ca.us)
- Make materials from the process available to the public (via www.grav.k12.ca.us)
- Regular Board Meeting Dec 12, 2018 at 5pm in Gravenstein Room 13
- Additional Special Board meetings may need to be scheduled before and/or after 12/12/18
- Board sets programming vision for 2019-20 in Dec 2018 – Jan 2019
- Staff works on the details to execute the Board's direction Jan 2019 – June 2019

7:30pm Participants may provide additional feedback via suggestion boxes & post-its

Thank you for participating in this Public Listening Session with the GUSD Board!

RESOURCE PACKET

GUSD BOARD OF TRUSTEES PUBLIC LISTENING SESSION

Wednesday, November 7, 2018

RE: Dual Program System & Vision for 2019-20 and Beyond

Includes:

- Donations collected for the Kindergarten Discovery Program for 2018-19 (as of 11/1/18)
- Reserves set aside to expand enrichments & Kindergarten Discovery (2018-2021)
- GUSD Parent/Guardian Survey Results, RE: Dual Program System (2018)
- Notes from District-wide Certificated Staff Meeting, RE: Dual Program System (12/6/16)
- GUSD Staff Survey Results, RE: Dual Program System (2018)

**Donations Collected for Discovery! Kindergarten Enrichments &
Grade Level Activities/Field Trips as of 10/24/2018**

Kindergarten Discovery Enrichments	
Ask per year	\$330
Enrollment	80
Total Possible	\$26,400
Collected so far	\$ 9,685
Participants	29
% of Participation	36%
% Collected	37%

* Some families took the option of 3 payments (more to come)

Field Trip Donations by Grade Level
--

	Received	Ask Per Student	Enrolled	Possible \$	% of Possible
Grade K	\$ 1,525.50	\$ 25	80	\$ 2,000	76%
Grade 1	\$ 1,455.00	\$ 25	70	\$ 1,750	83%
Grade 2	\$ 1,250.00	\$ 25	79	\$ 1,975	63%
Grade 3	\$ 2,595.00	\$ 50	79	\$ 3,950	66%
Grade 4	\$ 4,585.00	\$ 50	83	\$ 4,150	110%
Grade 5	\$ 10,040.00	\$ 250	94	\$ 23,500	43%
Grade 6	\$ 5,122.00	\$ 400	72	\$ 28,800	18%
Grade 7	\$ 7,100.00	\$ 150	96	\$ 14,400	49%
Grade 8	\$ 11,068.00	\$ 350	88	\$ 30,800	36%
	\$ 44,740.50			\$ 111,325	40%

Reserves and Ending Balance

Components of Ending Balance:	2018-19	2019-20	2020-21
Revolving Cash (nonspendable)	\$ 1,000	\$ 1,000	\$ 1,000
Restricted: Prepaid Expenditures	\$ -	\$ -	\$ -
Restricted	\$ 343,442	\$ 189,681	\$ 30,256
Other Assignments			
Textbook Adoptions Multi Year	\$ 350,000	\$ 350,000	\$ 350,000
Kindergarten Discovery! 2018-19	\$ 16,520	\$ -	\$ -
Kindergarten Discovery! 1 Year Reserve	\$ 31,508	\$ 31,508	\$ 31,508
Facilities Master Plan Approved Projects	\$ 500,000	\$ 500,000	\$ 500,000
STRS & PERS Increases 2 Years	\$ 108,612	\$ 108,612	\$ 108,612
Reserve for Enrichments 5 Years	\$ 1,500,000	\$ 1,500,000	\$ 1,500,000
30% Rainy Day Reserve	\$ 1,874,174	\$ 1,916,547	\$ 1,959,486
Reserve for Econ.Uncert. (unassigned)	\$ 313,527	\$ 302,964	\$ 309,218
Unassigned/Unappropriated Amount	\$ 747,975	\$ 453,000	\$ 121,852
Net Ending Balance	\$ 5,786,758	\$ 5,353,312	\$ 4,911,932

GUSD Parent/Guardian Survey Results

Fall 2017

How many years have your children attended GUSD?

374 responses

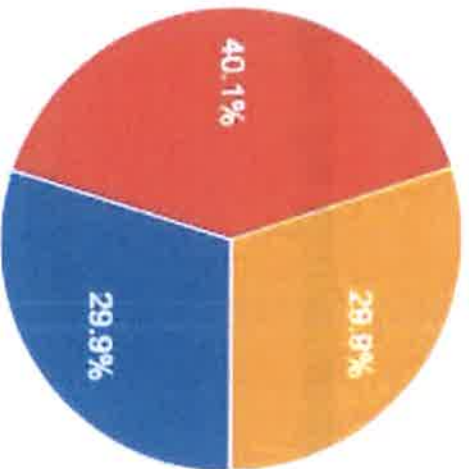

- 1-2 years
- 3-5 years
- 6+ years



If you live outside of the Gravenstein District, how many miles do you drive one-way to school?

267 responses

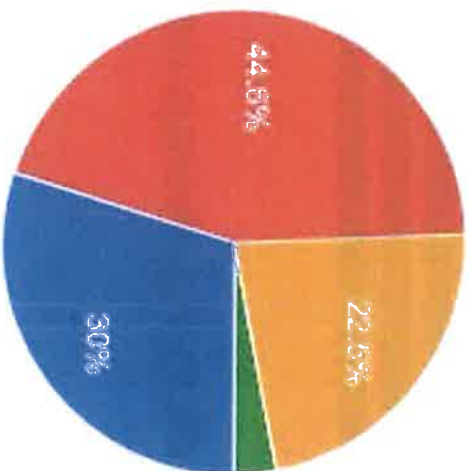

- 0-5 miles
- 6-10 miles
- 11-20 miles
- More than 20 miles

How satisfied are you with the Gravenstein District overall?

376 responses

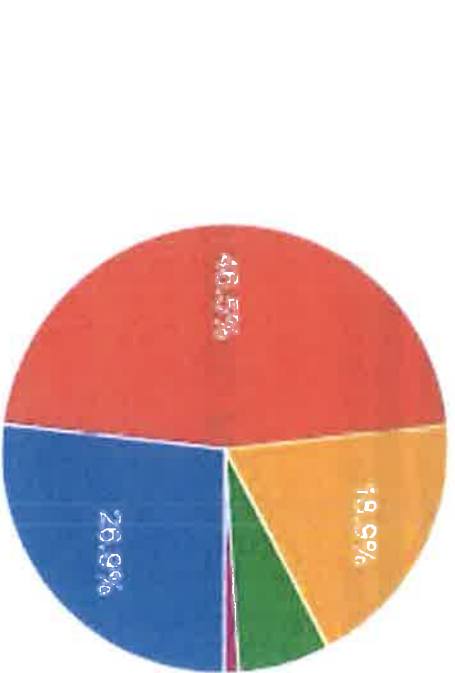

- Extremely Satisfied
- Very Satisfied
- Satisfied
- Somewhat Satisfied
- Not Satisfied

How satisfied are you with GUSD having a dual program system (Traditional and ENRICH! programs)

375 responses

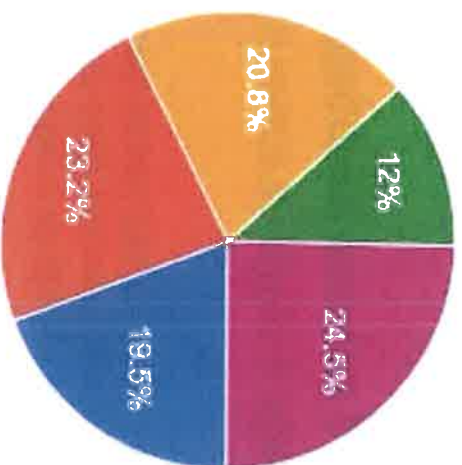

- Extremely Satisfied
- Very Satisfied
- Satisfied
- Somewhat Satisfied
- Not Satisfied

If your child was in the Kindergarten Discovery program (one program for all), and you applied for the ENRICH! program for first grade, and your child did not qualify, would you stay at Gravenstein?



If your child was in the Kindergarten Discovery program (one program for all), and you applied for the ENRICH! p... qualify, would you stay at Gravenstein?

358 responses

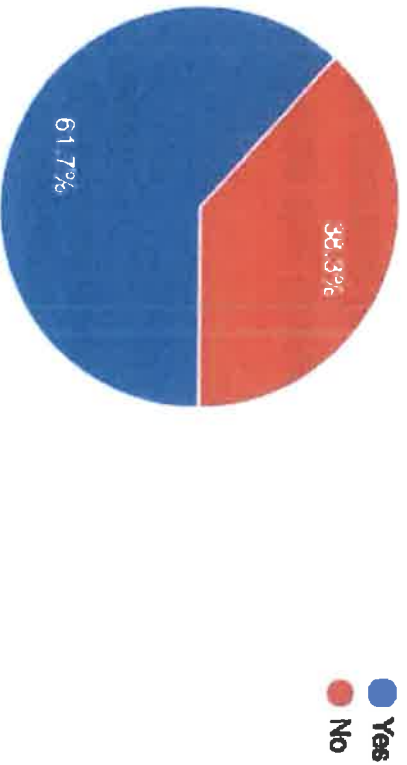

Count of If in the next school year, GUSD offered ONE program with daily courses (eg. art, music, hands-on science...) and field trips, in addition to the core curriculum in your child's grade level(s), how likely would you be to continue enrollment in our District?

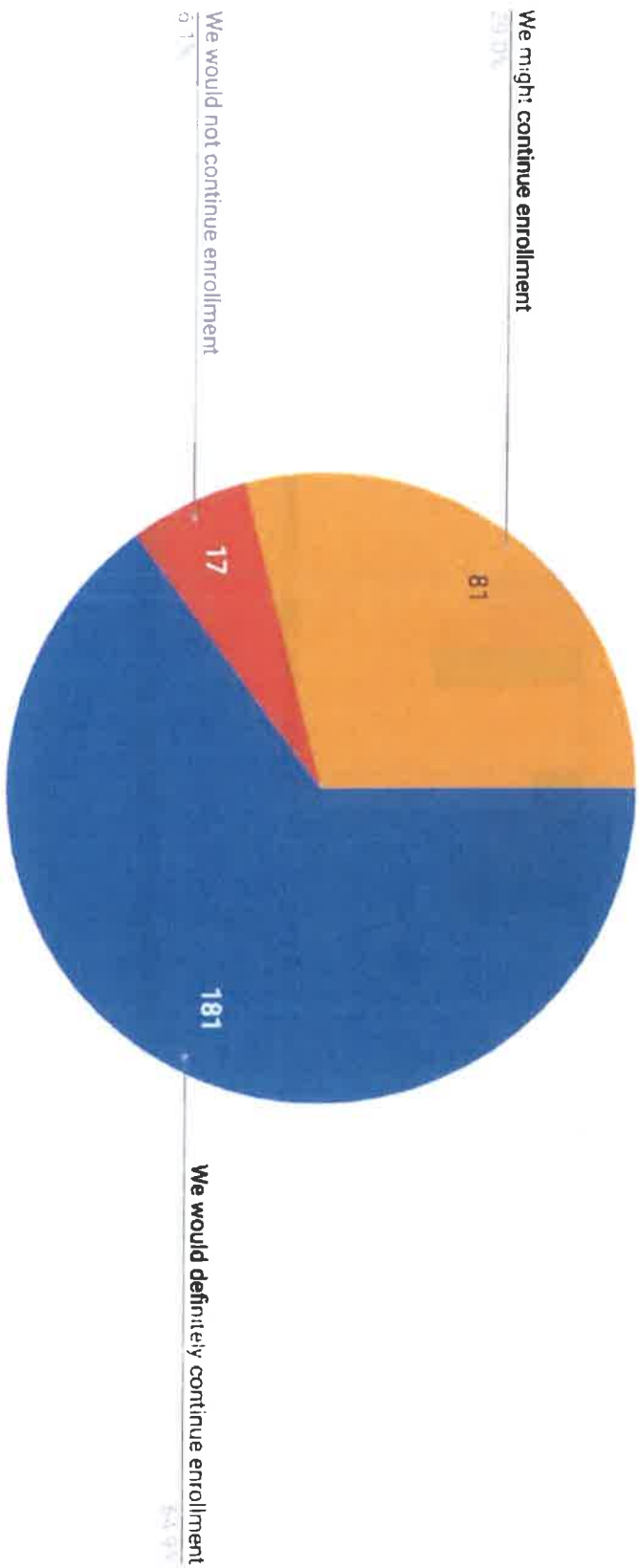

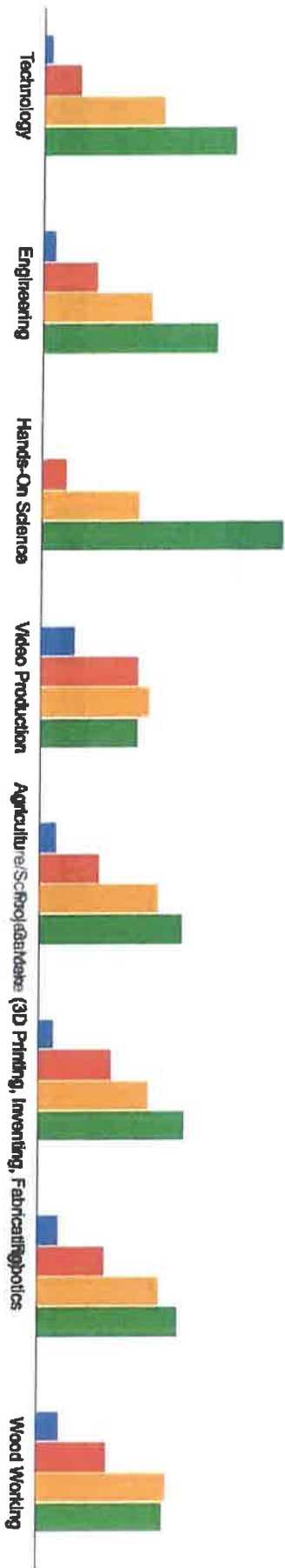

The ENRICH! program currently provides enrichment courses through the support of suggested parent contributi...or able to donate monthly (per child)?

359 responses

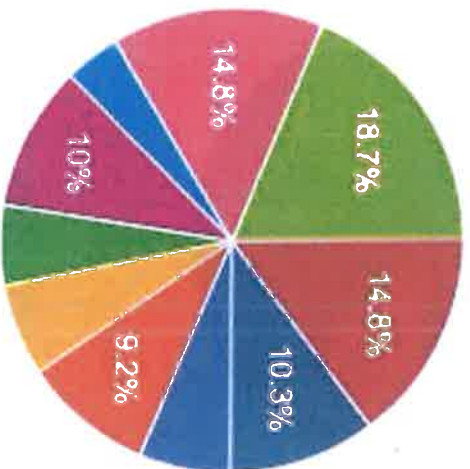

- Not willing to donate
- Not able to donate
- \$5 - \$20 per month
- \$21 - \$40 per month
- \$41 - \$60 per month
- \$61 - \$80 per month
- \$81 - \$100 per month
- \$101 - \$150 per month

1/2

At what level are you willing or able to donate annually (per child) to support field trips?

358 responses

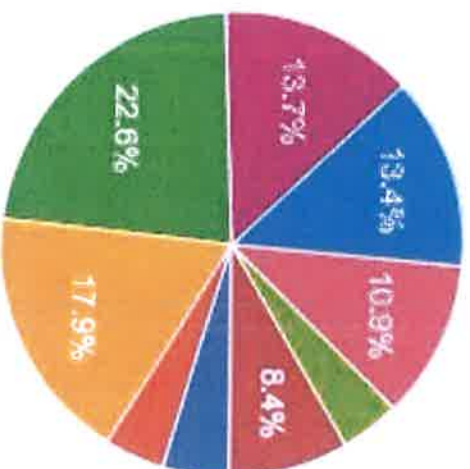

- Not willing to donate
- Not able to donate
- \$20 - \$60 per year
- \$61 - \$100 per year
- \$101 - \$150 per year
- \$151 - \$200 per year
- \$200 - \$300 per year
- \$300 - \$400 per year
- More than \$400 per year

What elements of the ENRICH! program are most important to you?

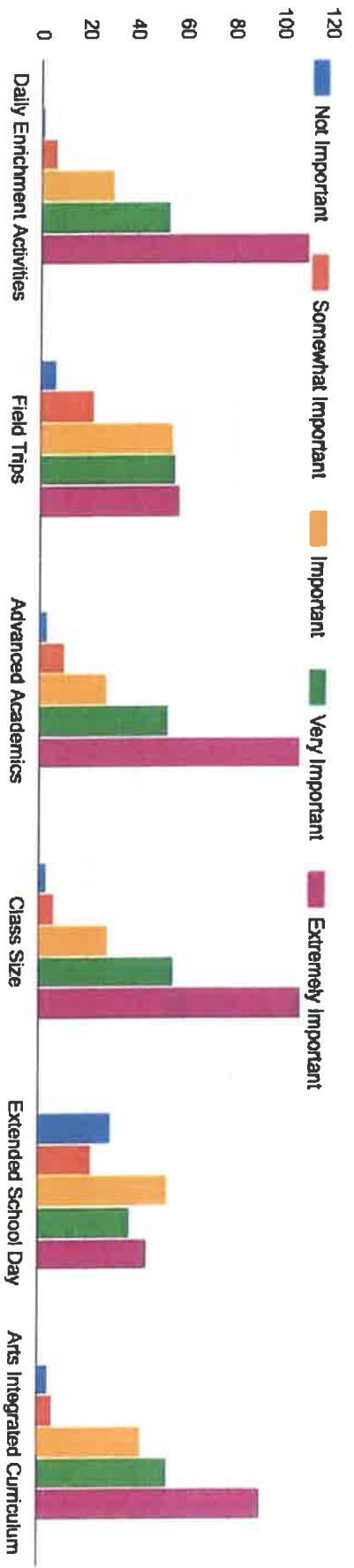

[Current Traditional Program Families]

Would you choose to have your student participate in an extended day program, that allows for daily courses in addition to the core curriculum?

116 responses

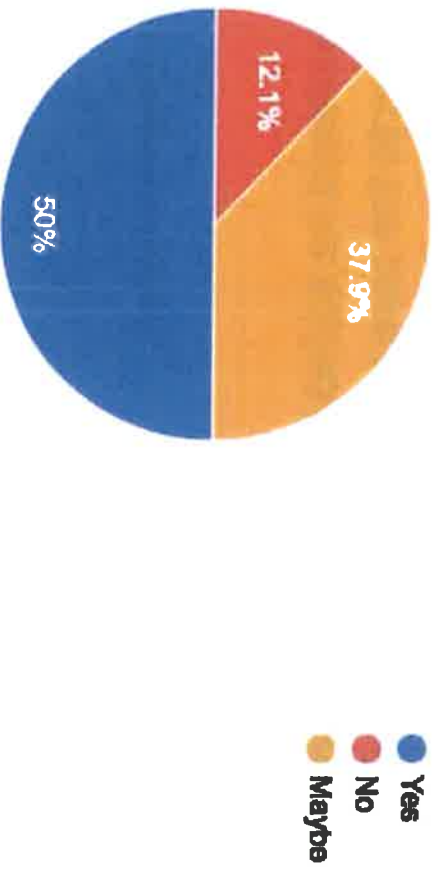

[Current Traditional Program Families]



How satisfied are you with the Traditional program?

116 responses

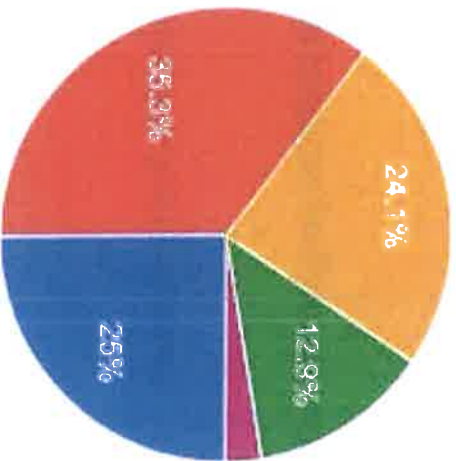

- Extremely Satisfied
- Very Satisfied
- Satisfied
- Somewhat Satisfied
- Not Satisfied

[Families with students in both programs]



How satisfied are you with the ENRICH! program?

25 responses

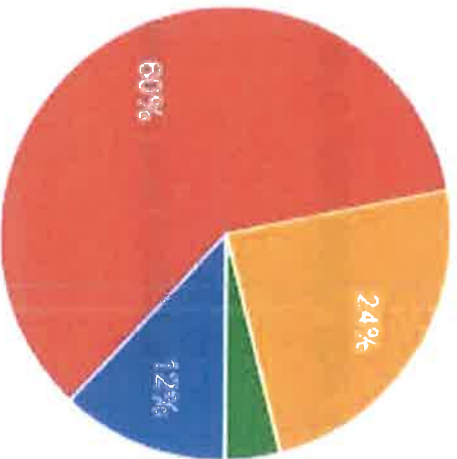

- Extremely Satisfied
- Very Satisfied
- Satisfied
- Somewhat satisfied
- Not satisfied

[Moved Traditional to ENRICH!]



What elements of the ENRICH! program are most important to you?

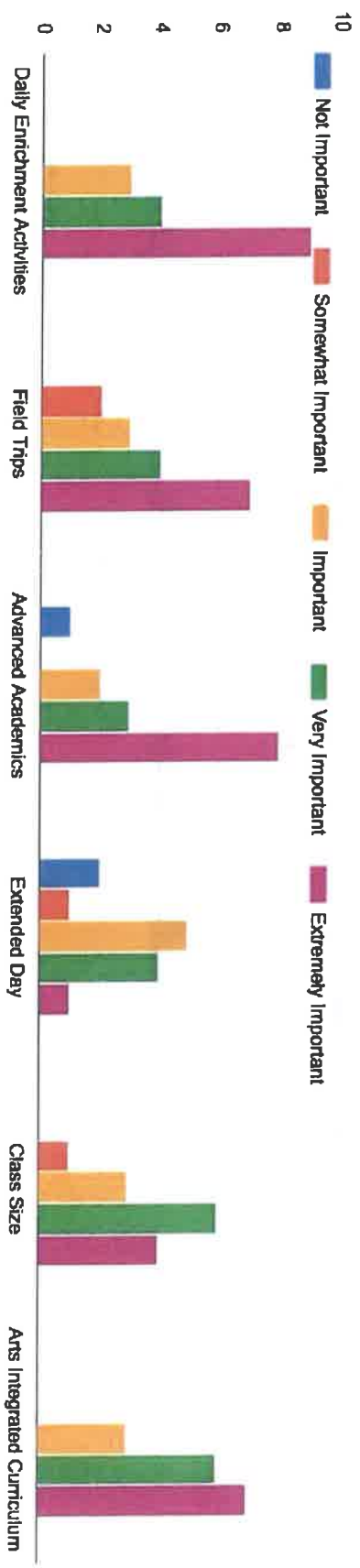

[Moved Traditional to ENRICH]



How satisfied were you with the Traditional program?

16 responses

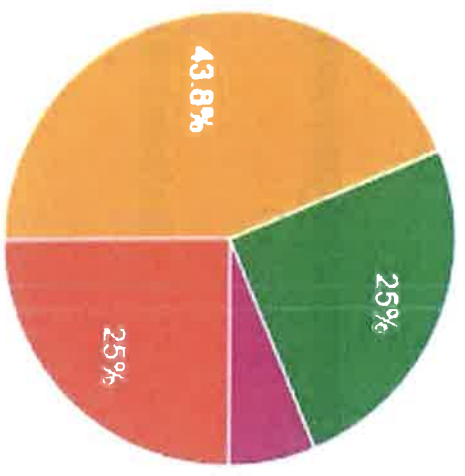

- Extremely Satisfied
- Very Satisfied
- Satisfied
- Somewhat Satisfied
- Not Satisfied

[Moved ENRICH! To Traditional]



How satisfied are you with the Traditional program? 14 responses

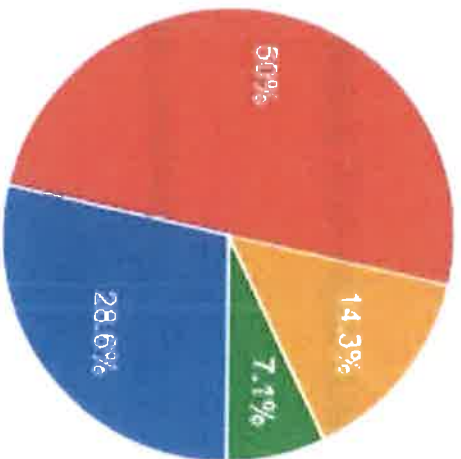

- Extremely Satisfied
- Very Satisfied
- Satisfied
- Somewhat Satisfied
- Not Satisfied

[Moved ENRICH! To Traditional]

What factors influenced your decision to change programs?

13 responses

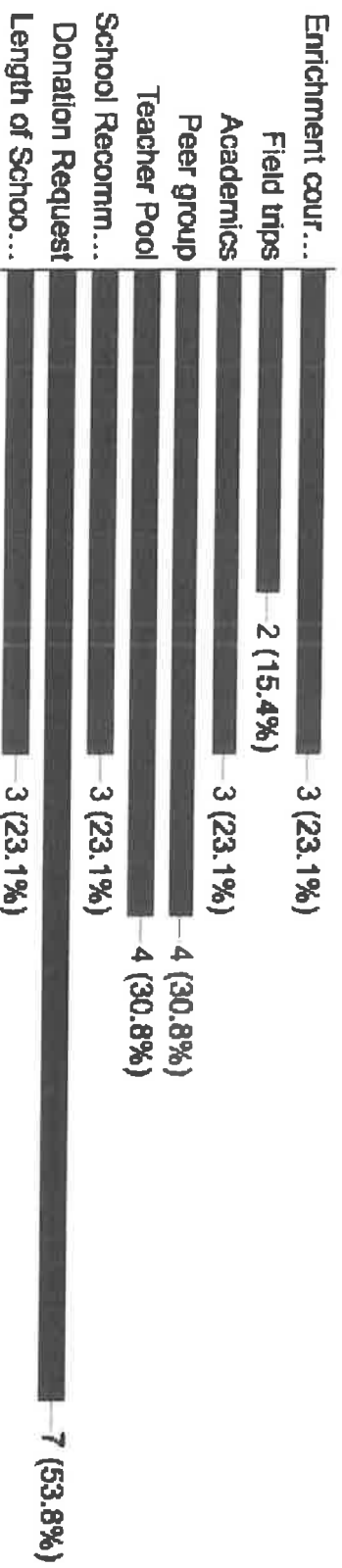



Traditional Program

Count of How satisfied are you with the Gravenstein District overall?

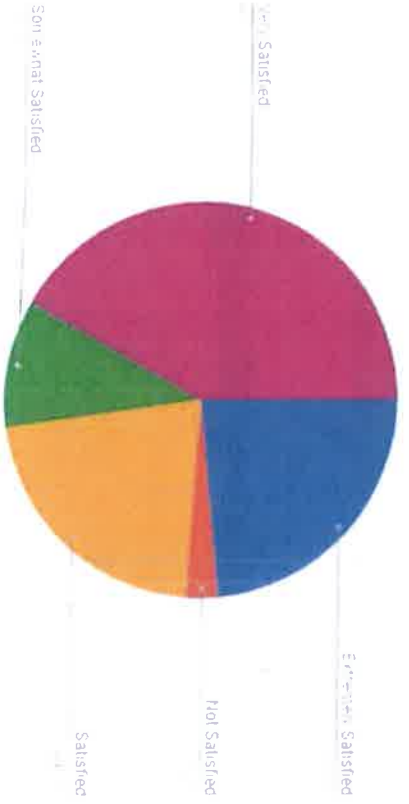

ENRICH! Program

How satisfied are you with the Gravenstein District overall?

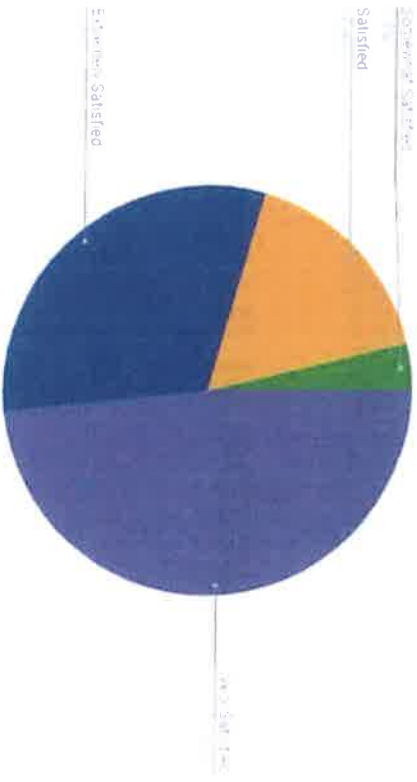



Traditional Program

Count of If Gravenstein were to offer a Kindergarten Discovery program, where all students are integrated into one program,...

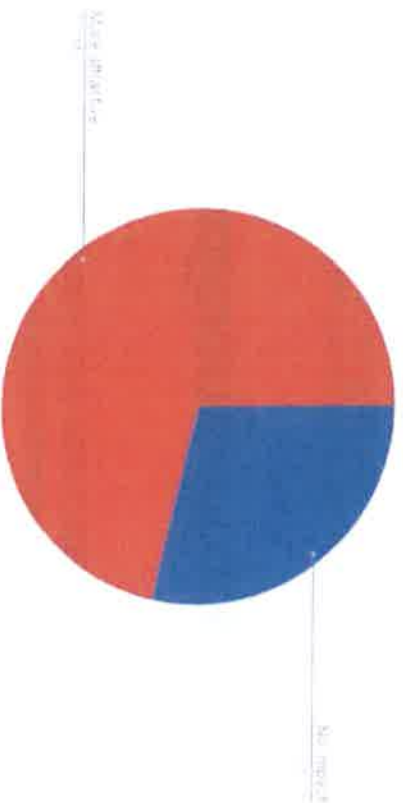

ENRICH! Program

If Gravenstein were to offer a Kindergarten Discovery program, where all students are integrated into one program, with daily...

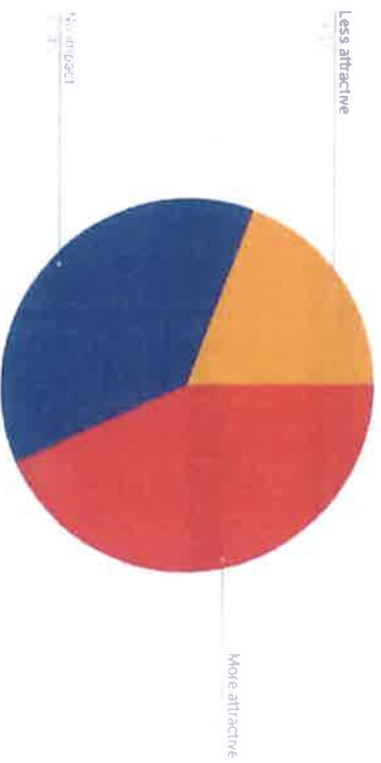



Traditional Program

Would you prefer that the Gravenstein District offer ONE program for all students, with daily courses (eg. art, music, ha...

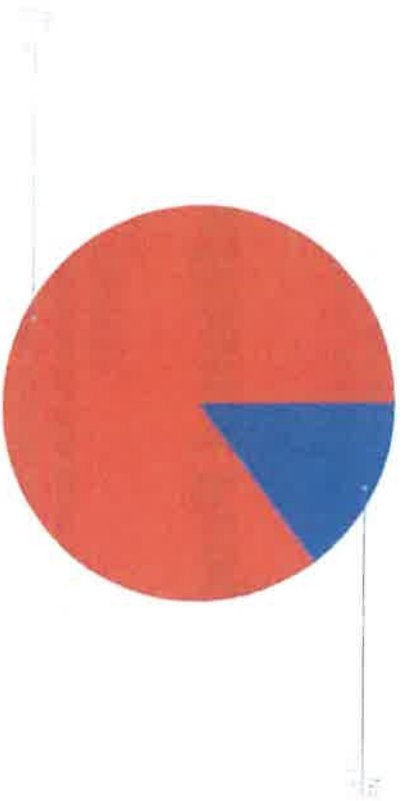

ENRICH! Program

Would you prefer that the Gravenstein District offer ONE program for all students, with daily courses (eg. art, music, ha...

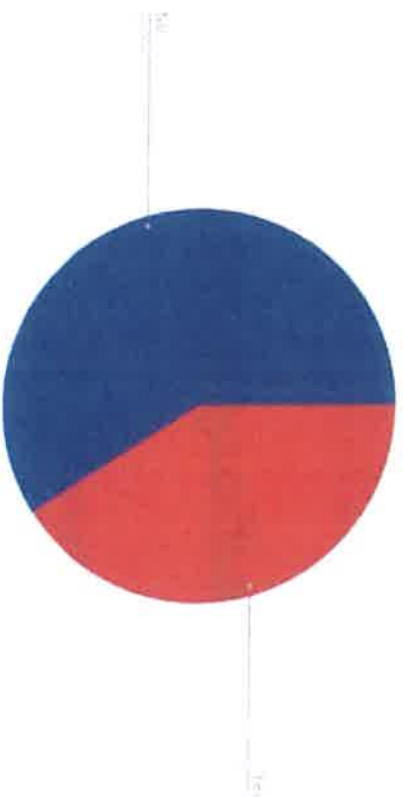

TK & Pre-School Aged Responses

If Gravenstein were to offer a Kindergarten Discovery program, where all students are integrated into one program, with daily courses (eg. art, music, hands-on science...) and field trips in addition to the core curriculum, would this make Gravenstein:

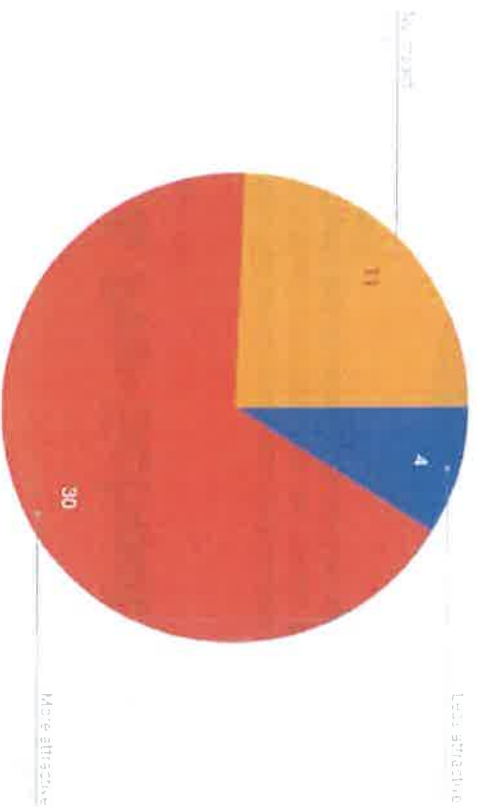

If your child was in the Kindergarten Discovery program (one program for all), and you applied for the ENRICH! program for first grade, and your child did not qualify, would you stay at Gravenstein?

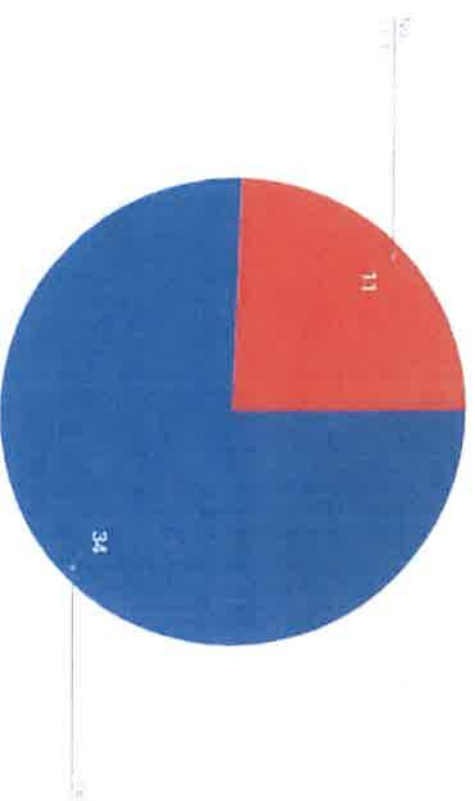

TK & Pre-School Aged Responses

If in the next school year, GUSD offered ONE program with daily courses (eg. art, music, hands-on science...) and field trips, in addition to the core curriculum in your child's grade level(s), how likely would you be to continue enrollment in our District?

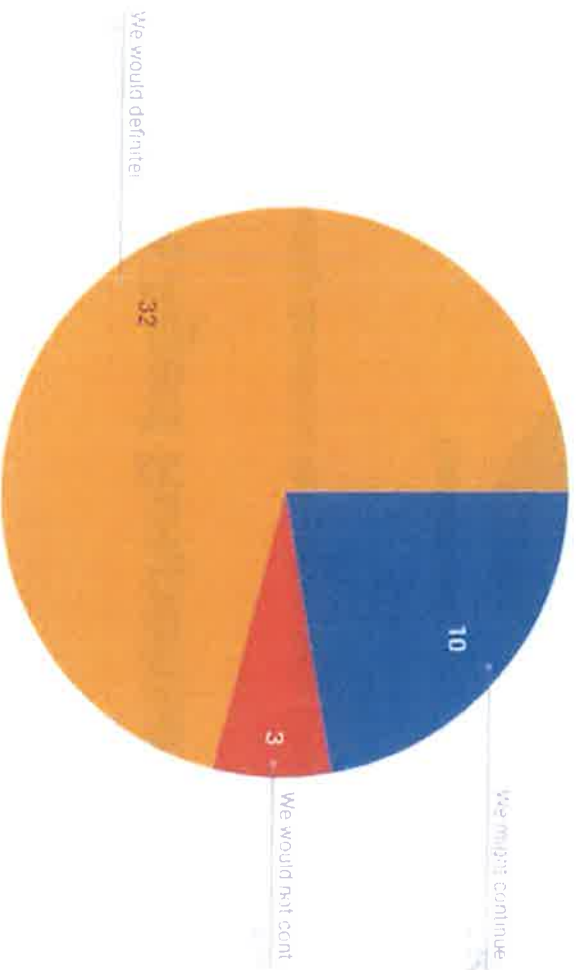

TK & Pre-School Aged Responses

Are you willing and able to make monthly donations to support daily courses in addition to the core curriculum?

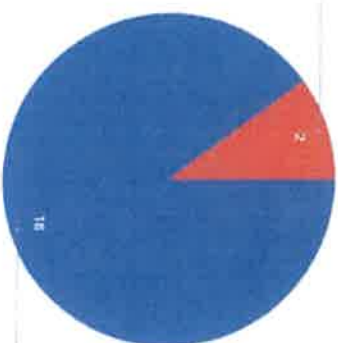
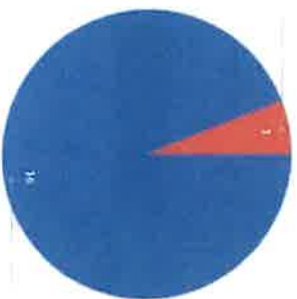
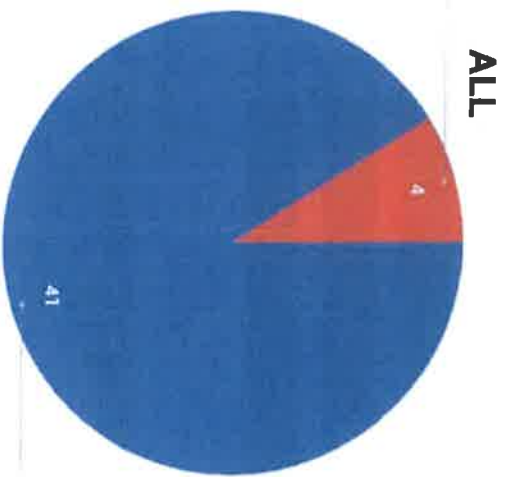

TK & Pre-School Aged Responses

The ENRICH! program currently provides enrichment courses through the support of suggested parent contributions ranging from \$125-\$220 per student, per month. To expand opportunities to ALL students, at what level are you willing or able to donate monthly (per child)?

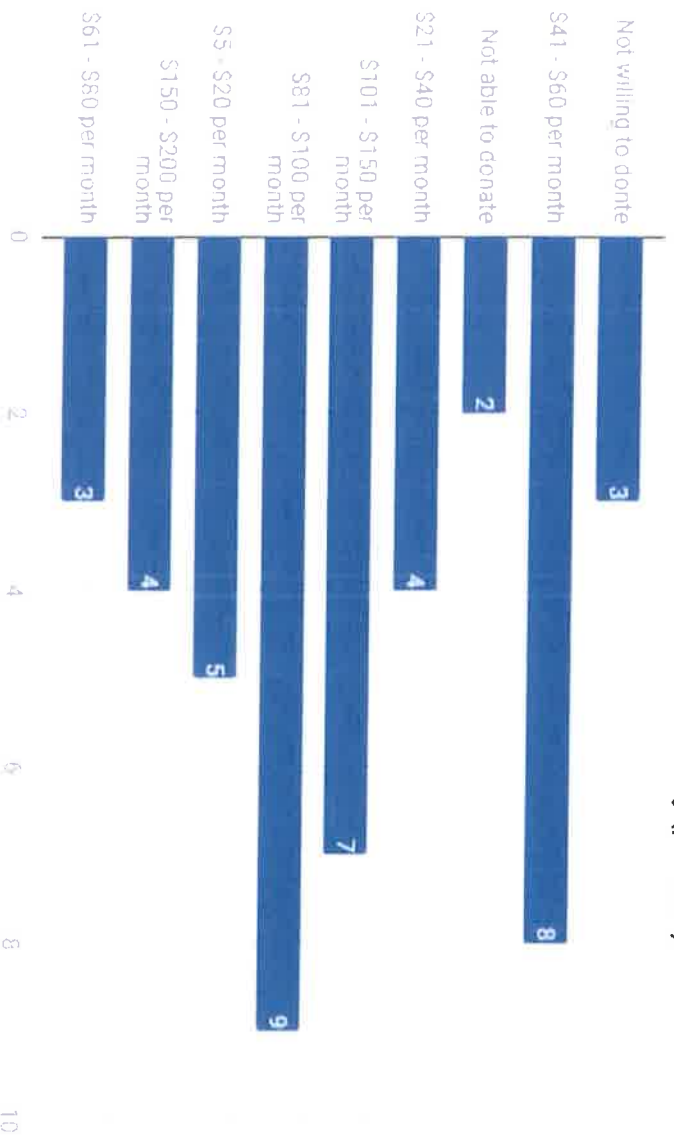

\$2,633 per month total, based on contributions at the lower end of the range.

**Notes from District-wide Certificated Staff Mtg
12/6/16:**

Enrich! & Traditional Teacher feedback Re: District's dual programs:

Strengths: Per Enrich! Teachers

- Families have historically been involved (\$, time, experience)
- Communication between grade level teachers
- Increased enrollment
- Parent choice – serve 2 populations
- Magnet program draws families to us (from out of district)

Strengths: Per Traditional Teachers

- Increased enrollment in District
- encourages competitive academics
- high performing schools
- good test scores
- same curriculum in each program
- GSF has stepped up!
 - More enrichment opportunities for Traditional (at elementary)
- Options available regarding class climate may help certain teachers/students (e.g. certain kids might flourish more in one climate than another)

Weaknesses: Per Enrich! Teachers

- Us/them ; Haves/have nots perception of self and others
- Choice between the two programs is not available for all, due to space limits and criteria
- Stark difference between the two programs
- Unreliable funding
- Concerns around homogenous grouping, rather than heterogeneous class groupings

Weaknesses: Per Traditional Teachers

- Decreased enrollment in the Traditional program
- Lack of creative opportunities for Trad. Students
- Perception of the Trad program is “2nd best “
Example: Language heard around campus, such as “ _____ was sent ‘back down’ to the Traditional program”
- Parents say teachers in the Trad program are “not as good;” the students are “not as good.”
- Therefore, there is pressure on teachers to compete, to prove their worth

- There are too many behavior problems concentrated in the Trad classrooms
- There are different behavior expectations in the two programs
 - As a result, problematic student behaviors may not be addressed as quickly. Instead just put the student in the Traditional program and call the behavior "OK" because they are in that program
- Dual program model hurts the self-concept of students who are in the Trad program
- Classist divide between the two programs
- Students with brown skin disproportionately in Traditional
- Little kids think "Enrich!" = "rich;" that the kids in the Enrich! program are the rich kids
- Inequality in teacher work conditions (e.g. In Trad: fewer prep periods; more behavior problems; more students with special needs to serve)

Questions we want to explore further:

- Does having two programs ultimately limit parent participation on campus?
- We want to gather the following demographic data:
 - What percentage of boys/girls in each program?
 - What percentage of students with IEPs in each program?
 - What percentage of EL students in each program?
- Why are the students separated? E.g. when both programs are going to same field trip (Yosemite) why not go together?
- What percentage of families from inside the District in each program?
- Are parents paying for enrichments for the exclusivity in selecting classmates in the E! program?

As a whole group, we explored... Opportunities for positive change:

- The change in administration provides opportunity to look at the dual programs with fresh eyes.
- Add more enrichments to Trad, but must pay for equal contribution to the E! program.
- Encourage more grade level team planning across the two programs to improve continuity between programs
- Can we house the grade levels together on the HMS campus?
- Better balance the teaching loads
- Rotate teaching assignments every two years. So teachers experience working in each program.

2018 GUSD Staff Survey Results

What is your role in GUSD?

53 responses

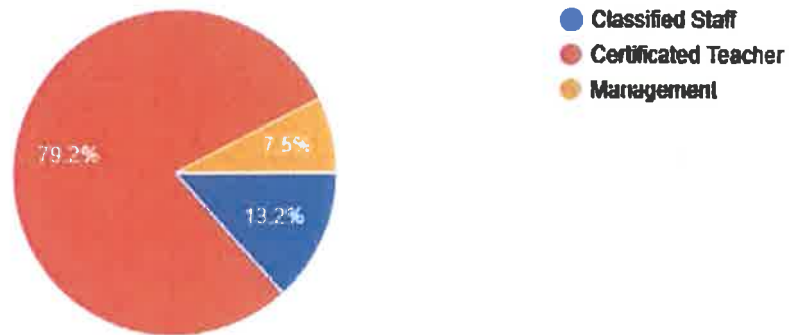

What campus do you work on?

51 responses

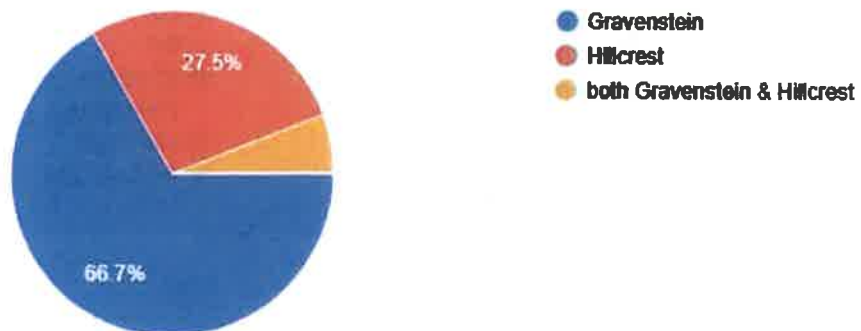

What about GUSD makes it an attractive place to work?

52 responses

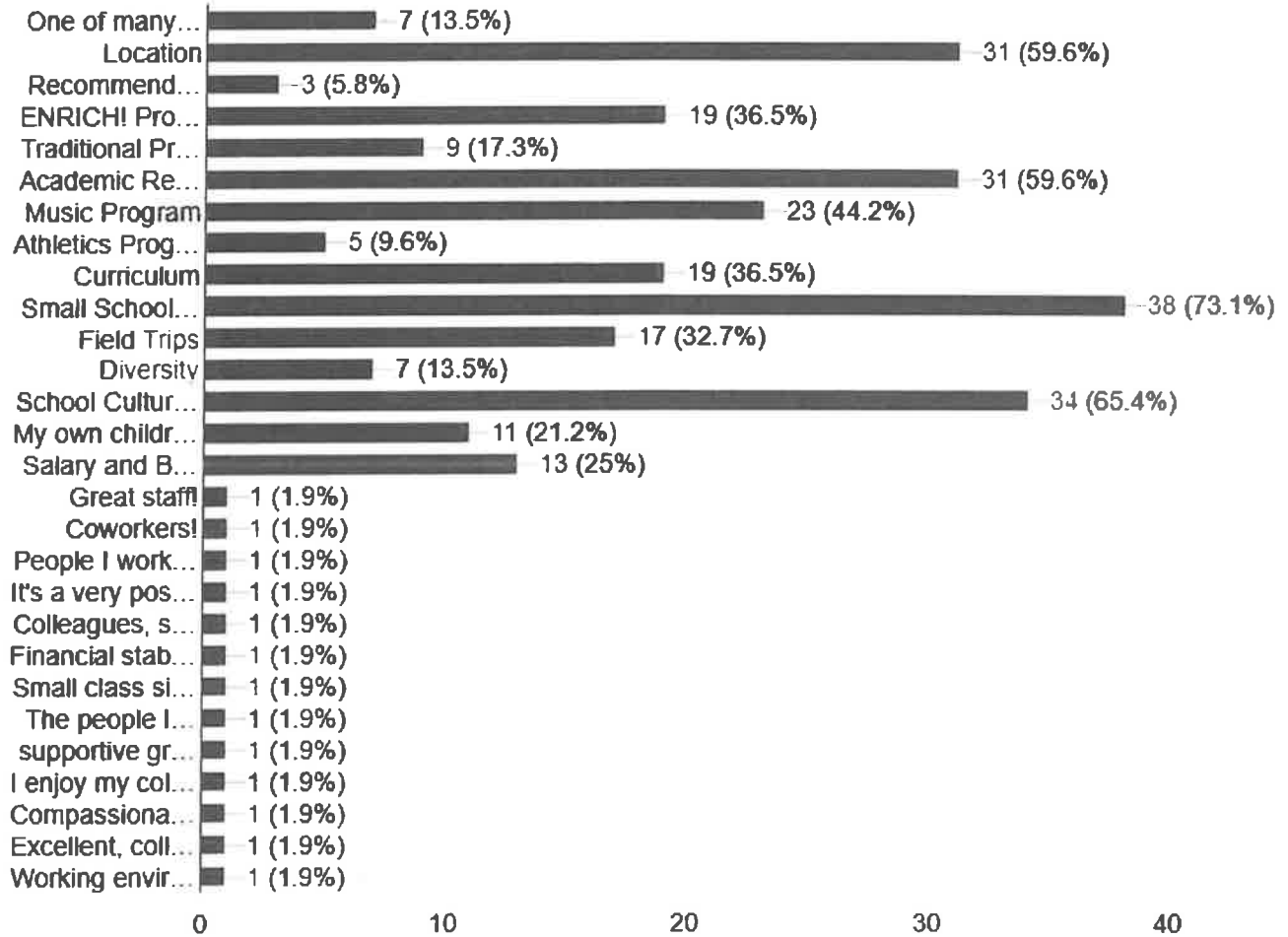

The options for this question are pasted below to clarify phrases that were truncated by the form.

How satisfied are you working within the Gravenstein District overall?

51 responses

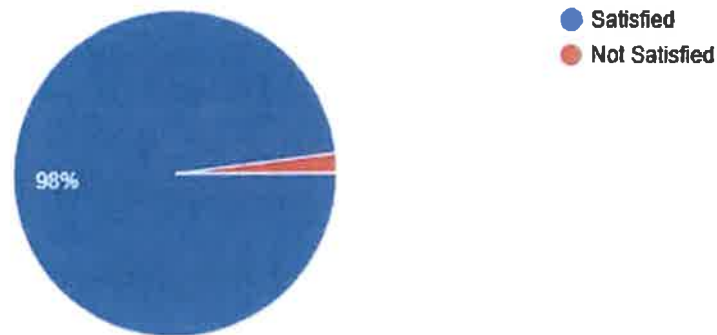

In what areas do you feel that GUSD needs significant improvement?

52 responses

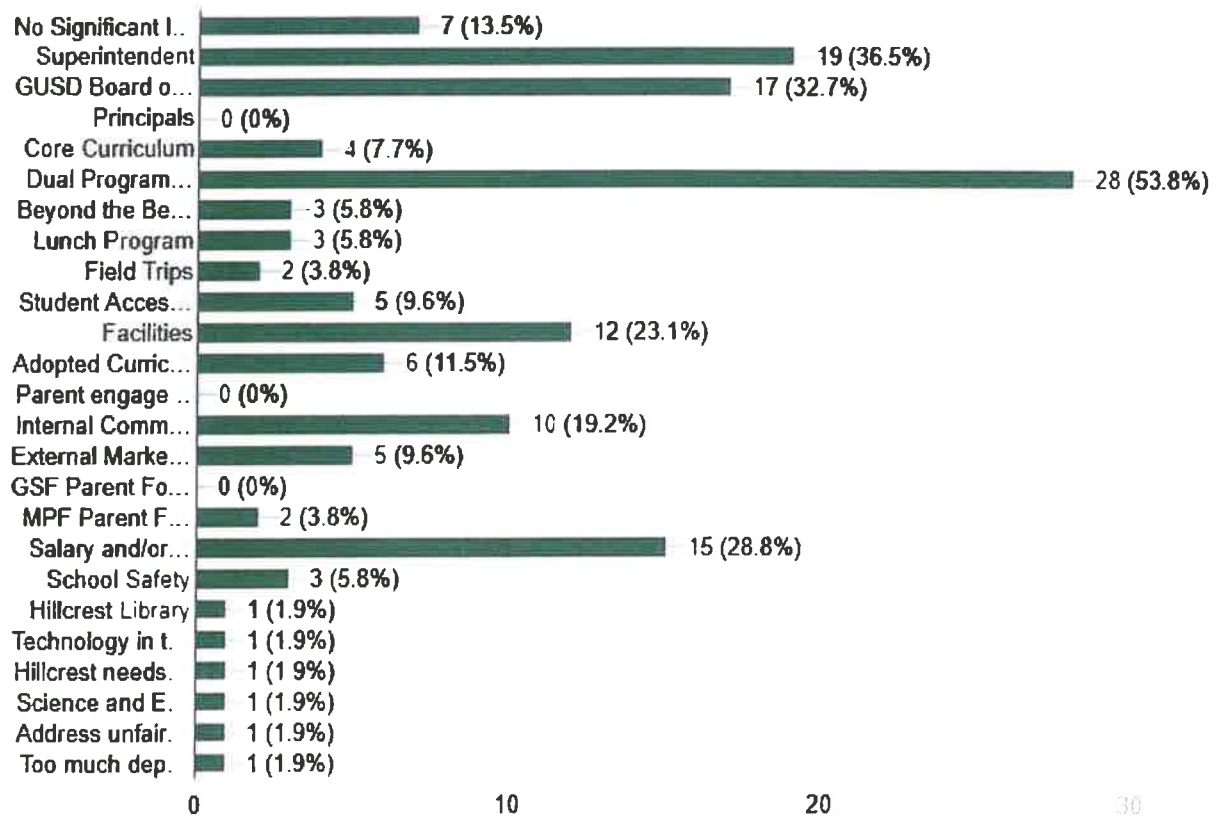

Count of Please share your satisfaction with the piloted Language Arts curriculum (TK-2 Responses)

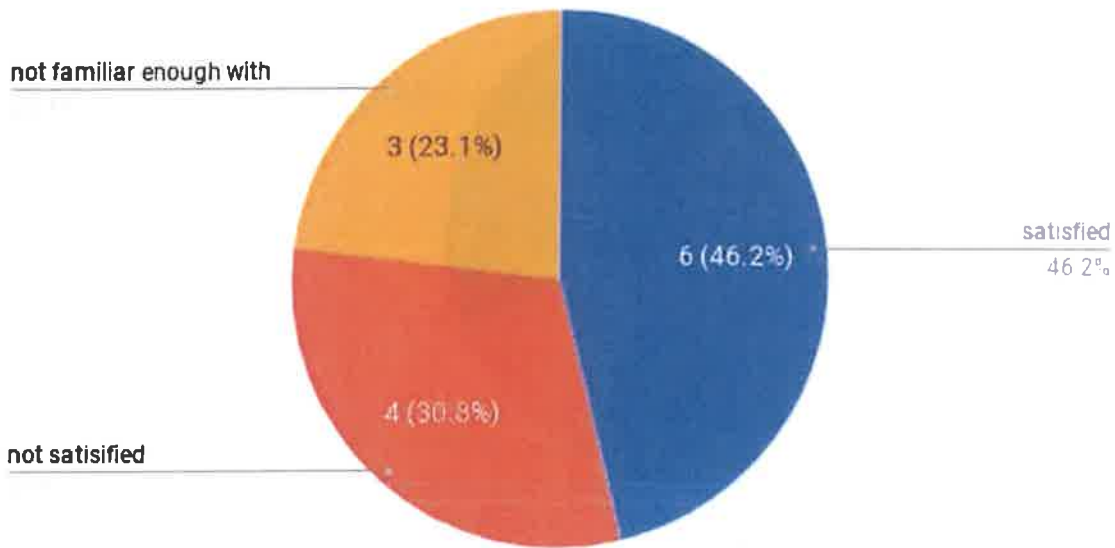

Count of Please share your satisfaction with the piloted Language Arts curriculum? (3-5 Responses)

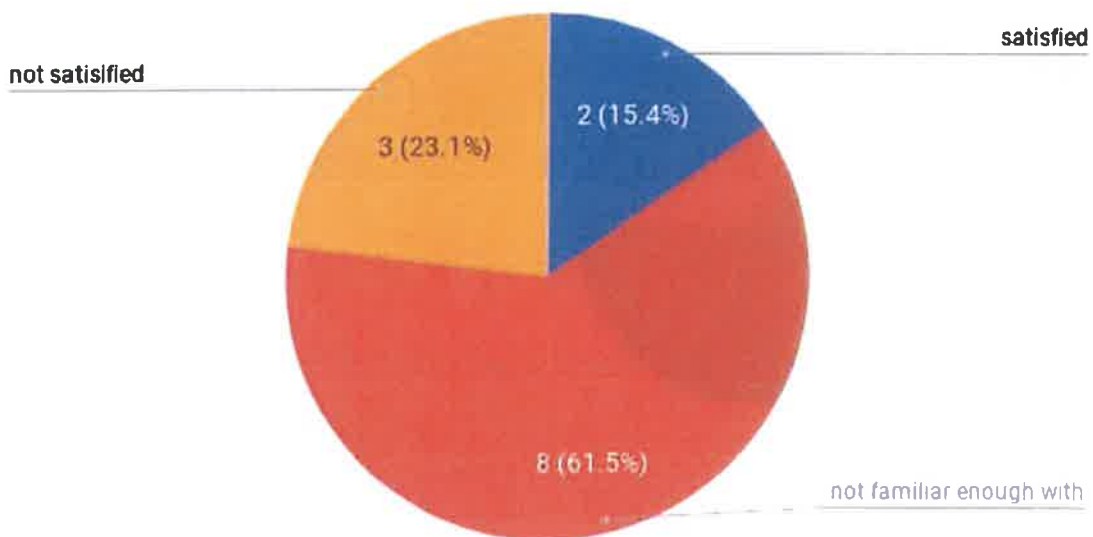

Count of Please share your satisfaction with the adopted Math curriculum? (TK-2 Responses)

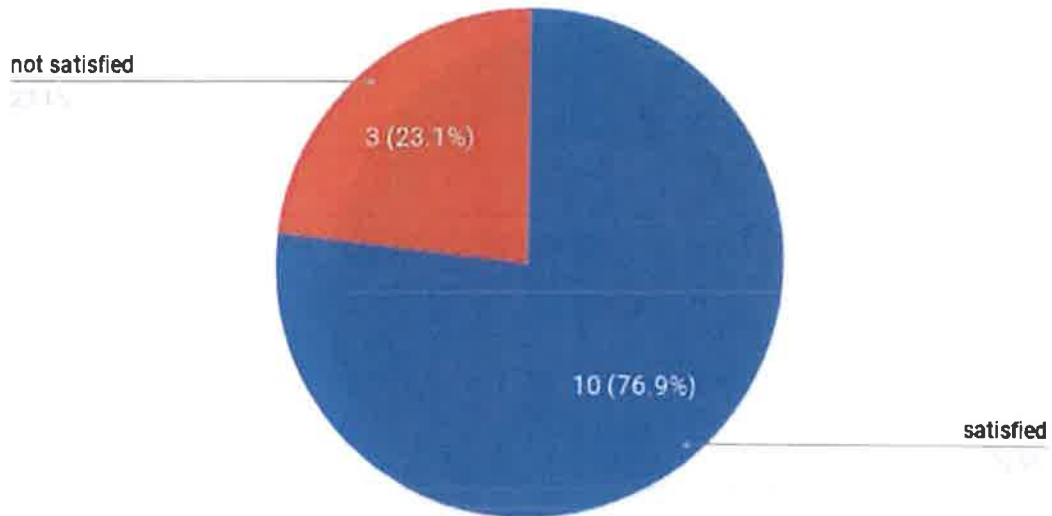

Count of Please share your satisfaction with the adopted Math curriculum? (3-5 Math)

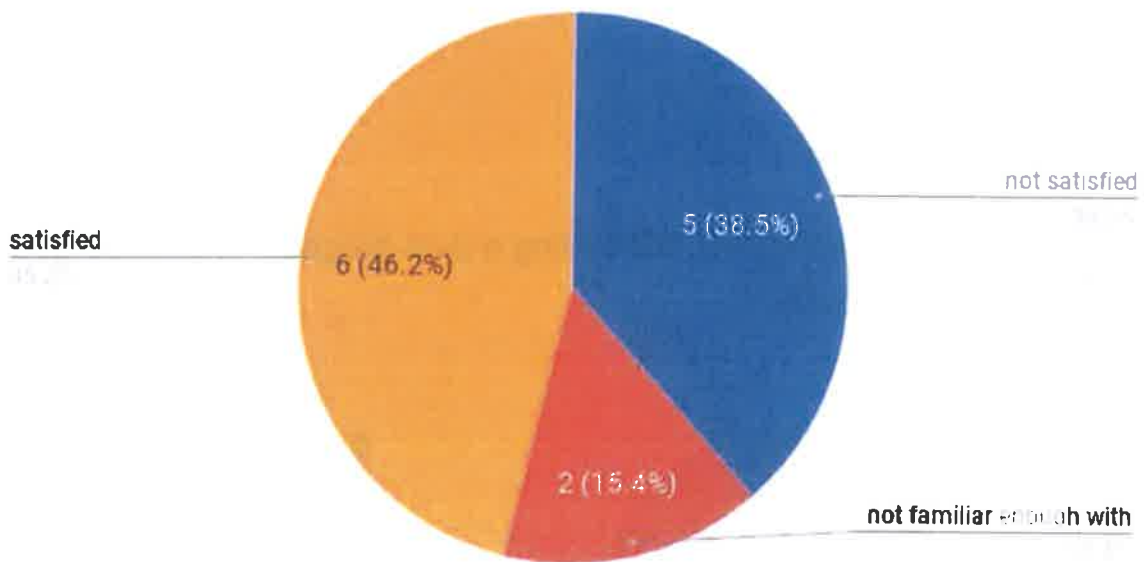

For the 2018-2019 school year, Gravenstein will be piloting a Kindergarten Discovery! program, where all students...you feel this will impact Gravenstein?

47 responses

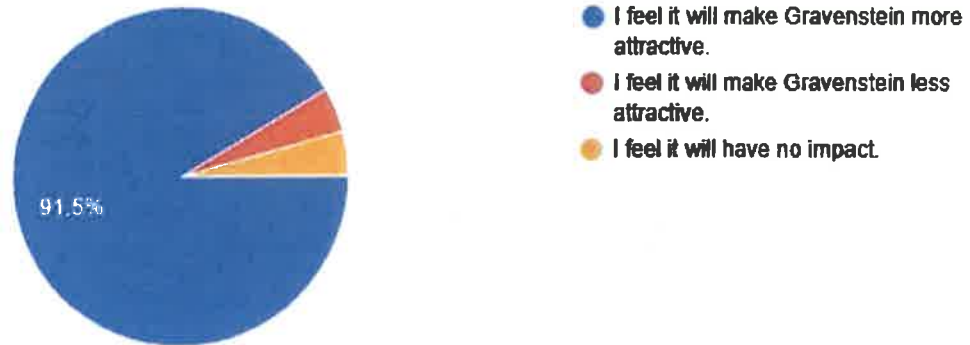

Would you prefer that the Gravenstein District offer ONE program for all students, with daily courses (eg. art, ... curriculum, rather than two programs?

48 responses

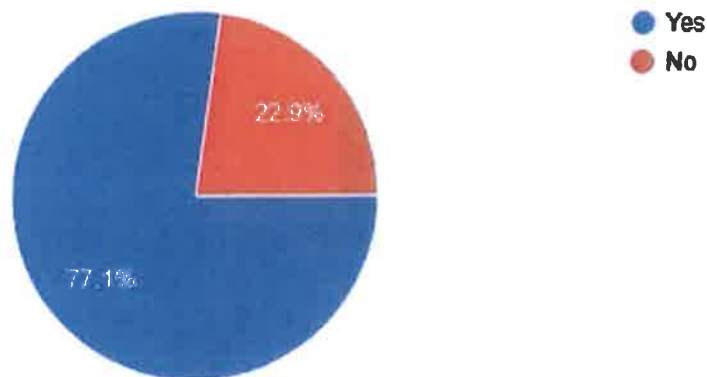

Count of Please rate the following subjects to be offered to elementary school students beyond the core curriculum: [Visual Art]

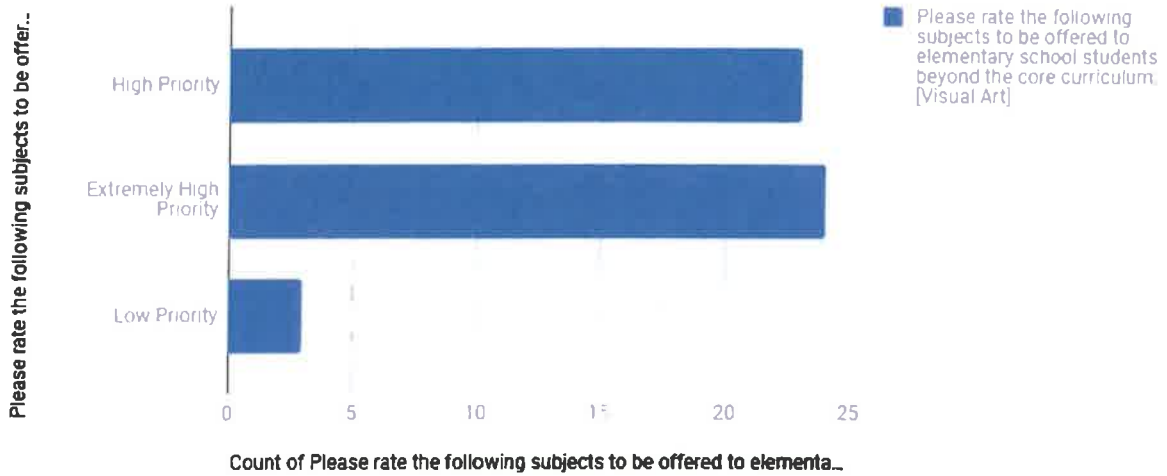

Count of Please rate the following subjects to be offered to elementary school students beyond the core curriculum: [Music]

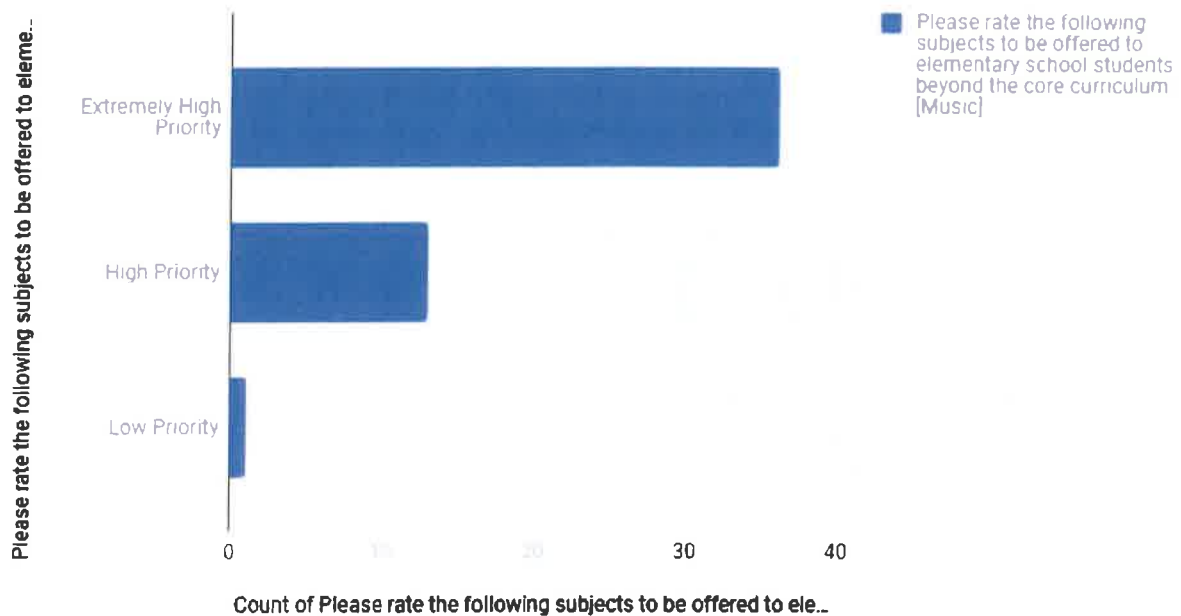

Count of Please rate the following subjects to be offered to elementary school students beyond the core curriculum: [Athletics/Movement]

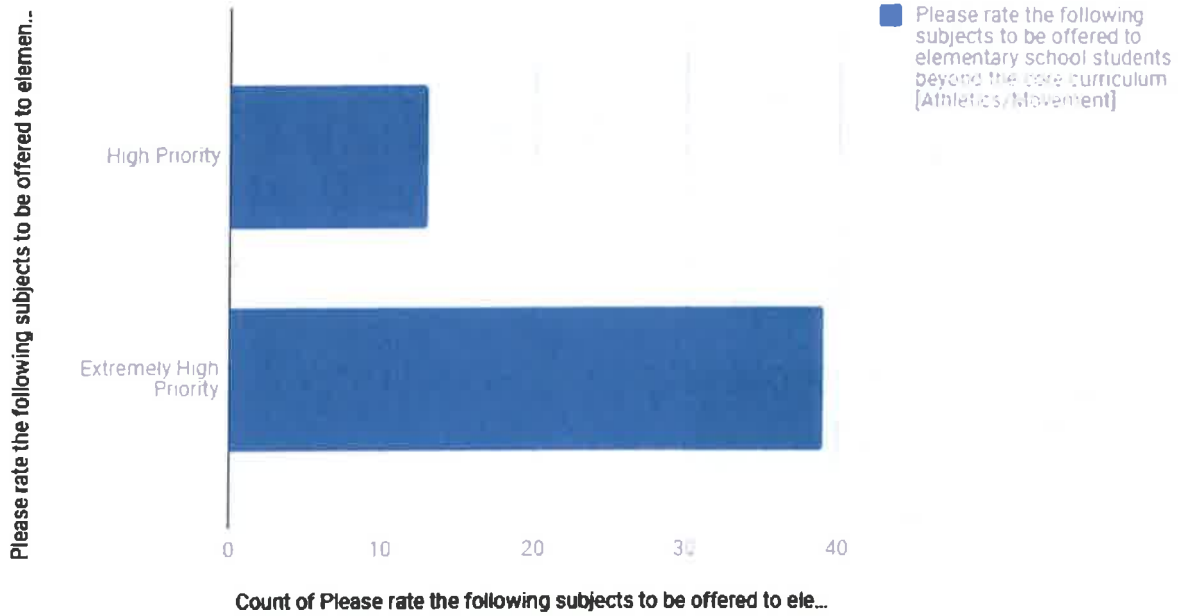

Count of Please rate the following subjects to be offered to elementary school students beyond the core curriculum: [Coding]

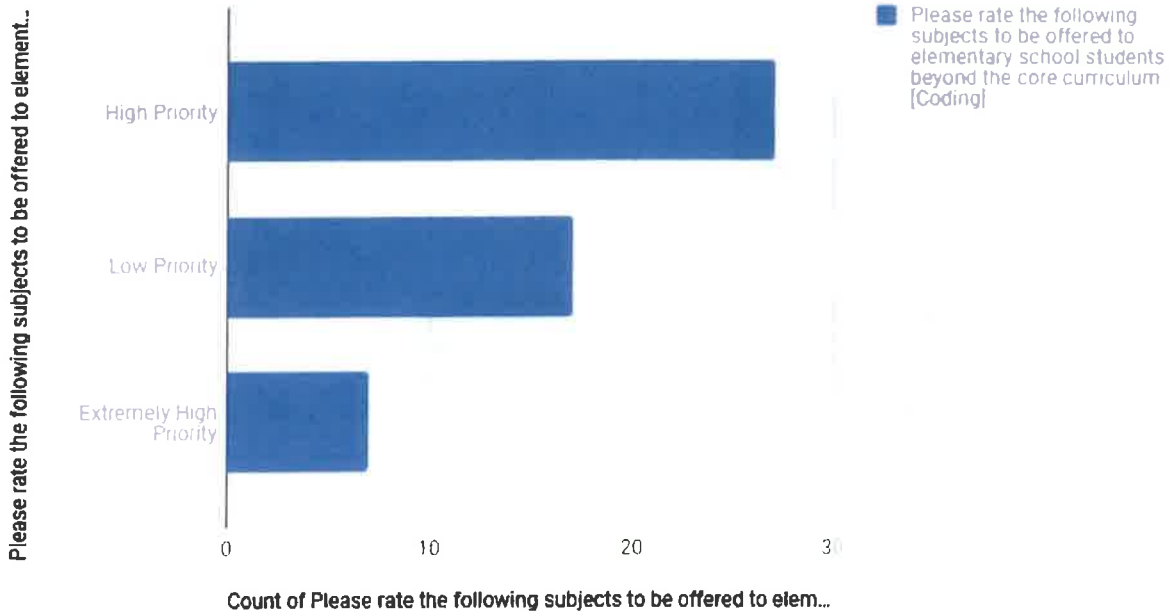

Count of Please rate the following subjects to be offered to elementary school students beyond the core curriculum: [Agriculture/School Garden]

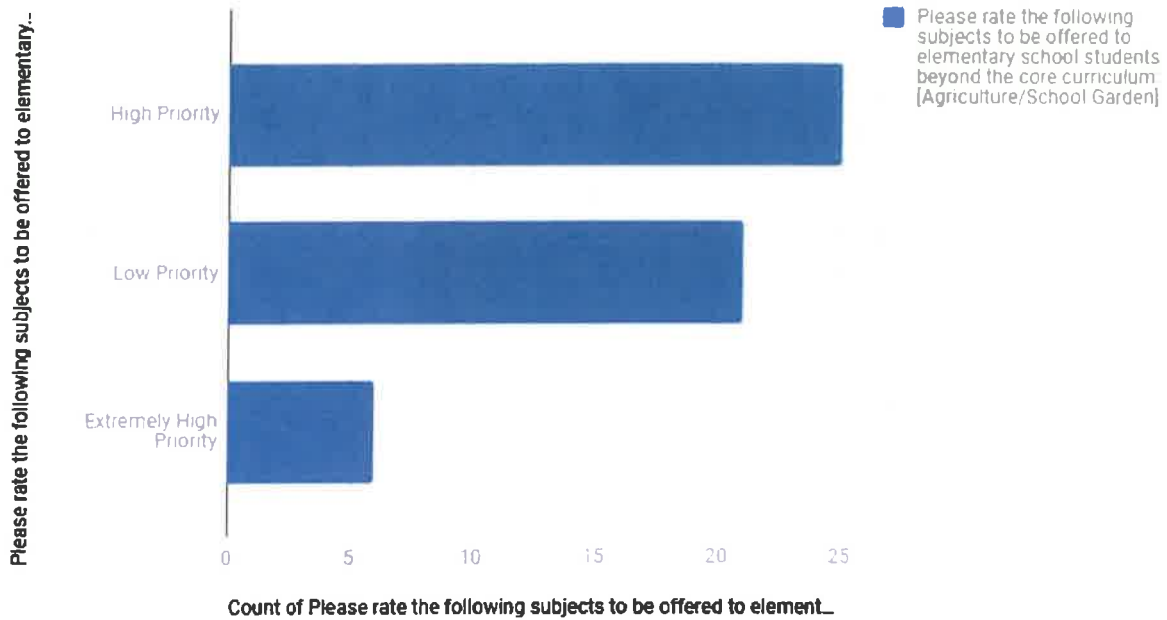

Count of Please rate the following subjects to be offered to elementary school students beyond the core curriculum: [Project Make (3D Printing, Inventing)]

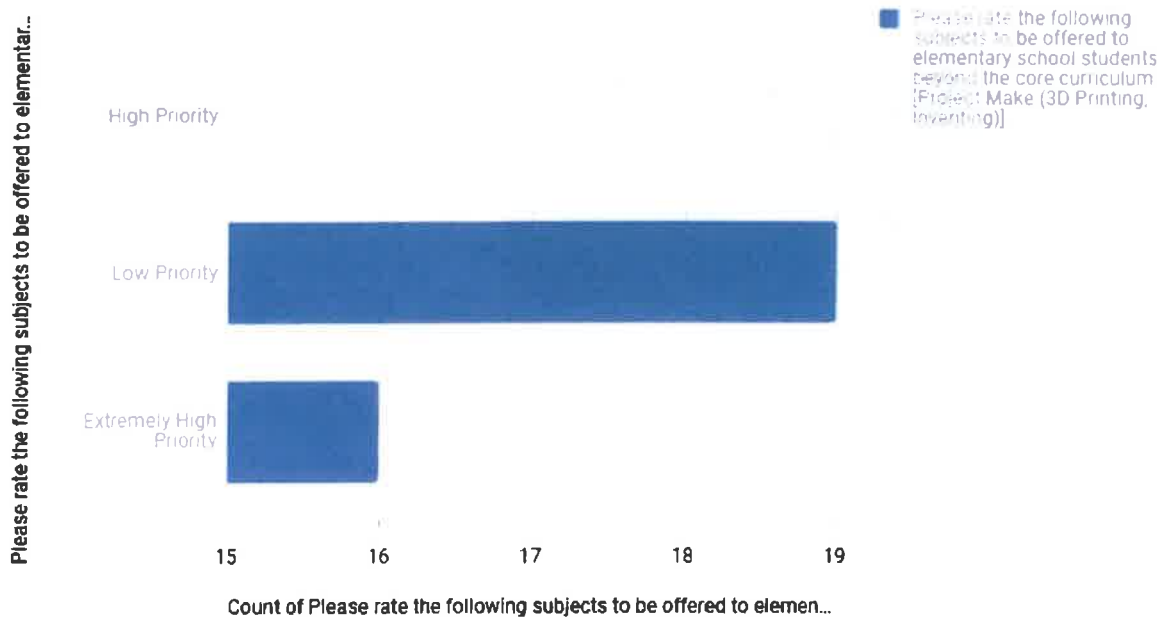

Count of Please rate the following subjects to be offered to elementary school students beyond the core curriculum: [other Foreign Language]

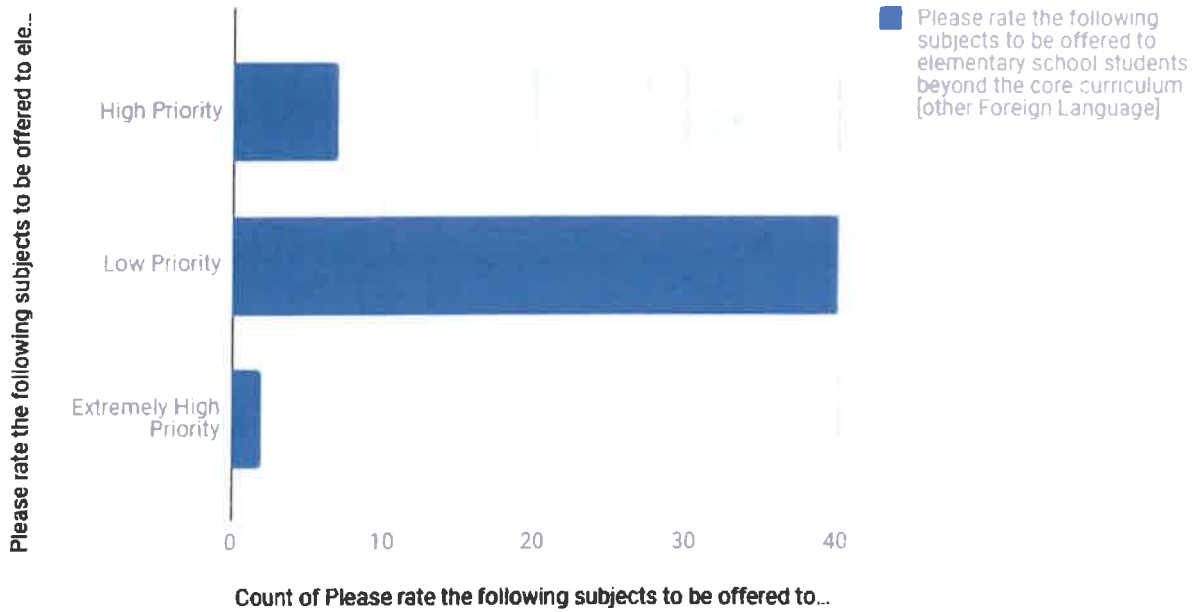

Count of Please rate the following subjects to be offered to middle school students beyond the core curriculum: [Visual Art]

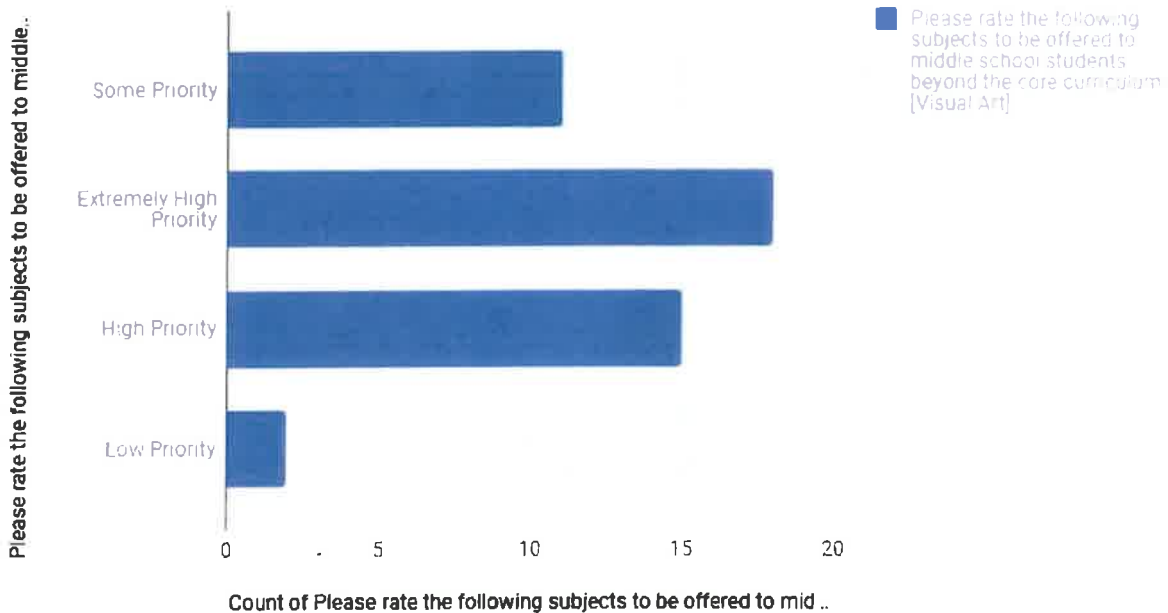

Count of Please rate the following subjects to be offered to middle school students beyond the core curriculum: [Music Production (eg digital music)]

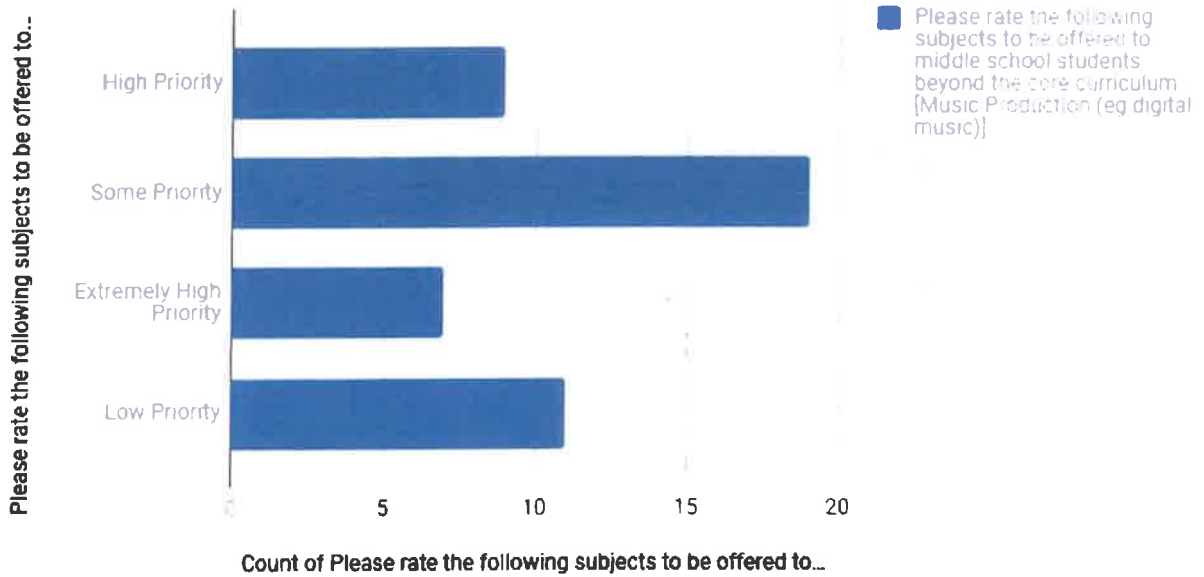

Count of Please rate the following subjects to be offered to middle school students beyond the core curriculum: [Drama]

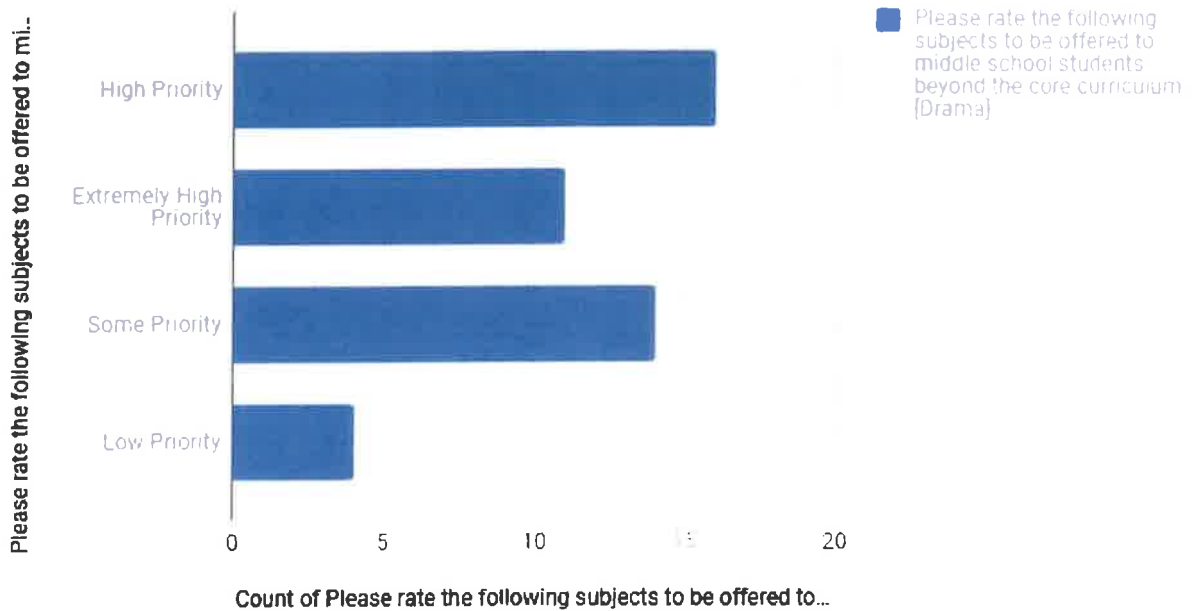

Count of Please rate the following subjects to be offered to middle school students beyond the core curriculum: [Team Athletics]

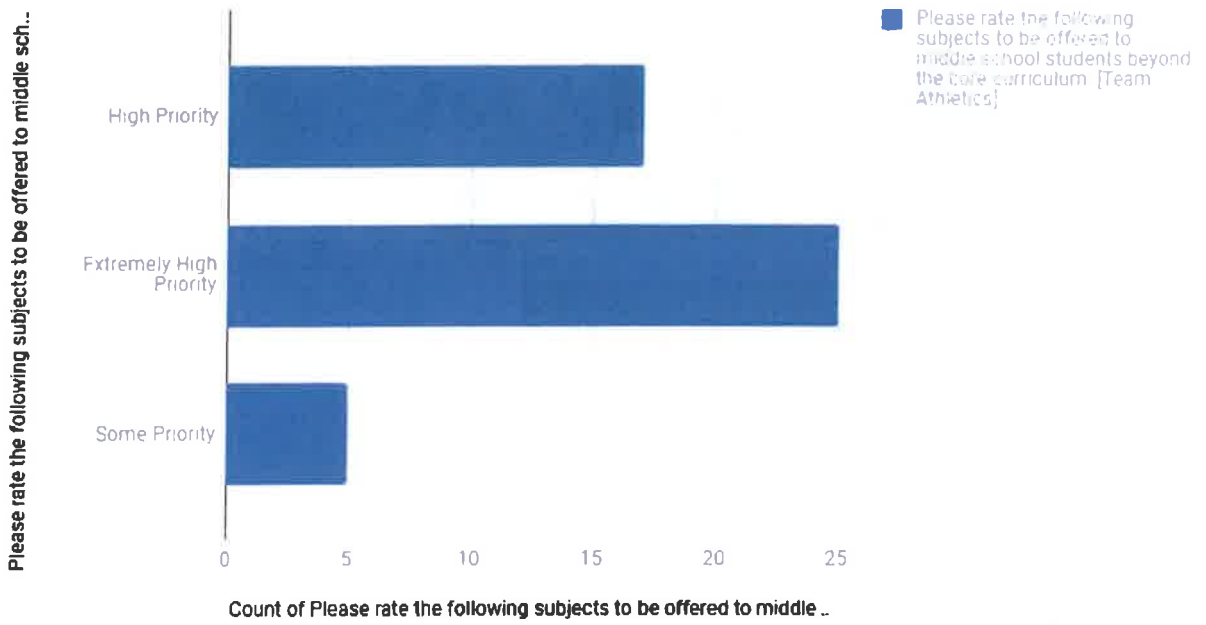

Count of Please rate the following subjects to be offered to middle school students beyond the core curriculum: [Engineering]

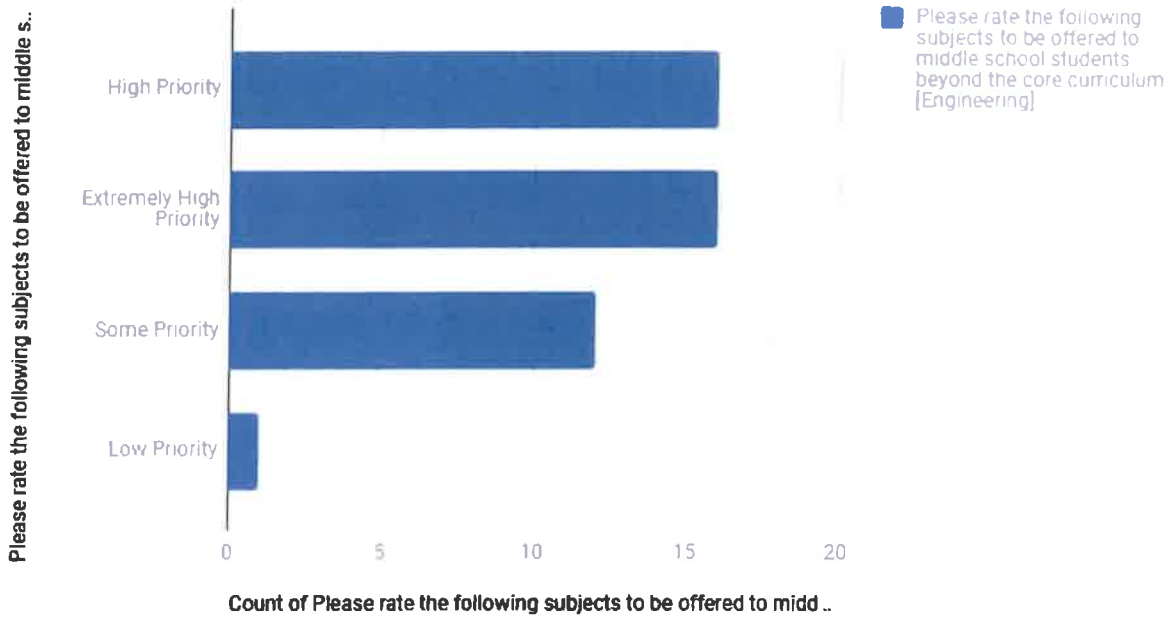

Count of Please rate the following subjects to be offered to middle school students beyond the core curriculum: [Hands-On Science]

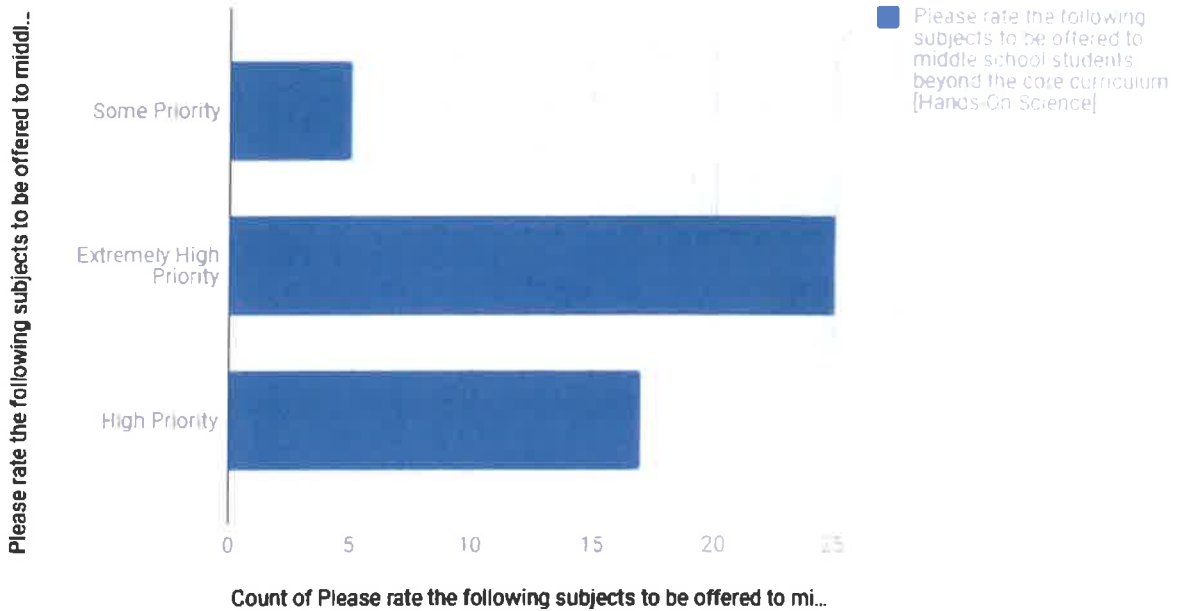

Count of Please rate the following subjects to be offered to middle school students beyond the core curriculum: [Spanish]

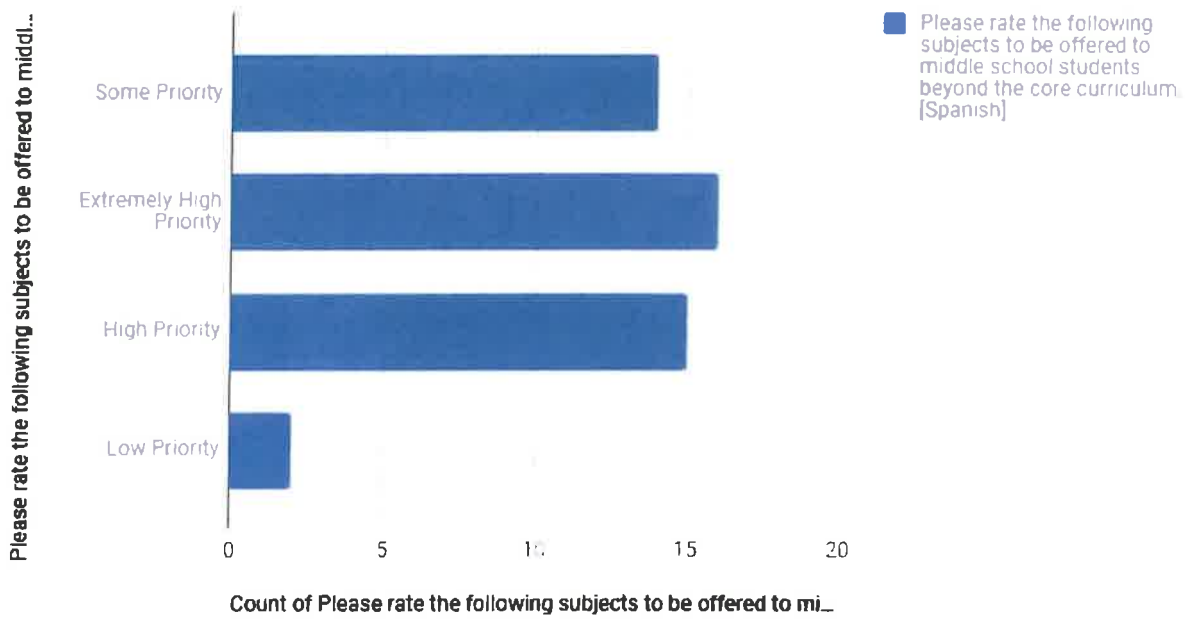

Count of Please rate the following subjects to be offered to middle school students beyond the core curriculum: [Poetry]

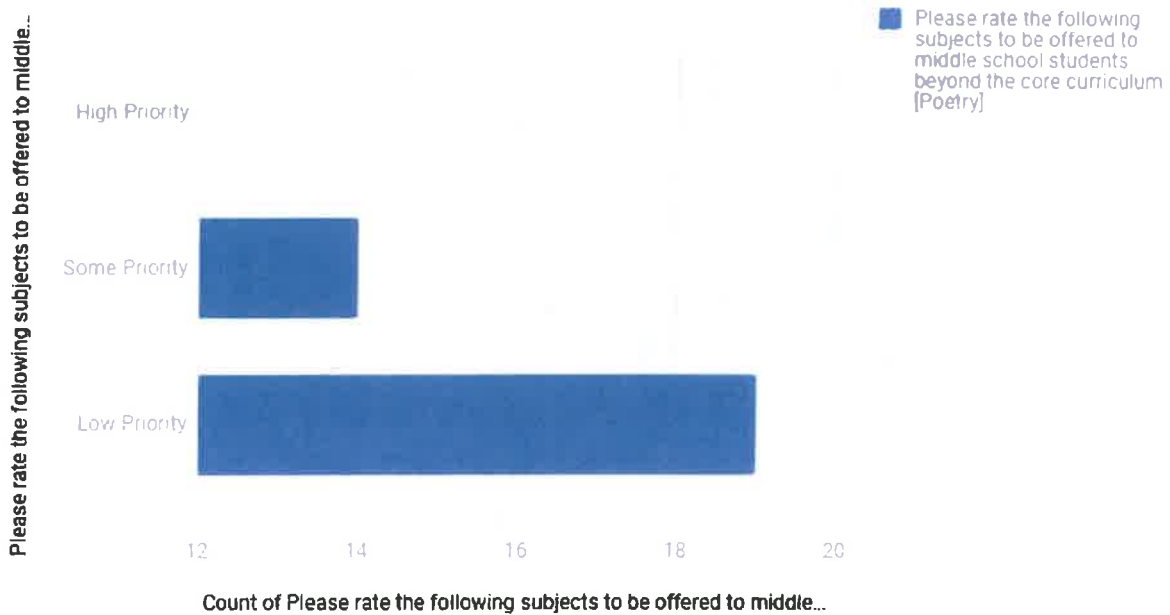

Count of Please rate the following subjects to be offered to middle school students beyond the core curriculum: [Project Make (3D Printing, Inventing)]

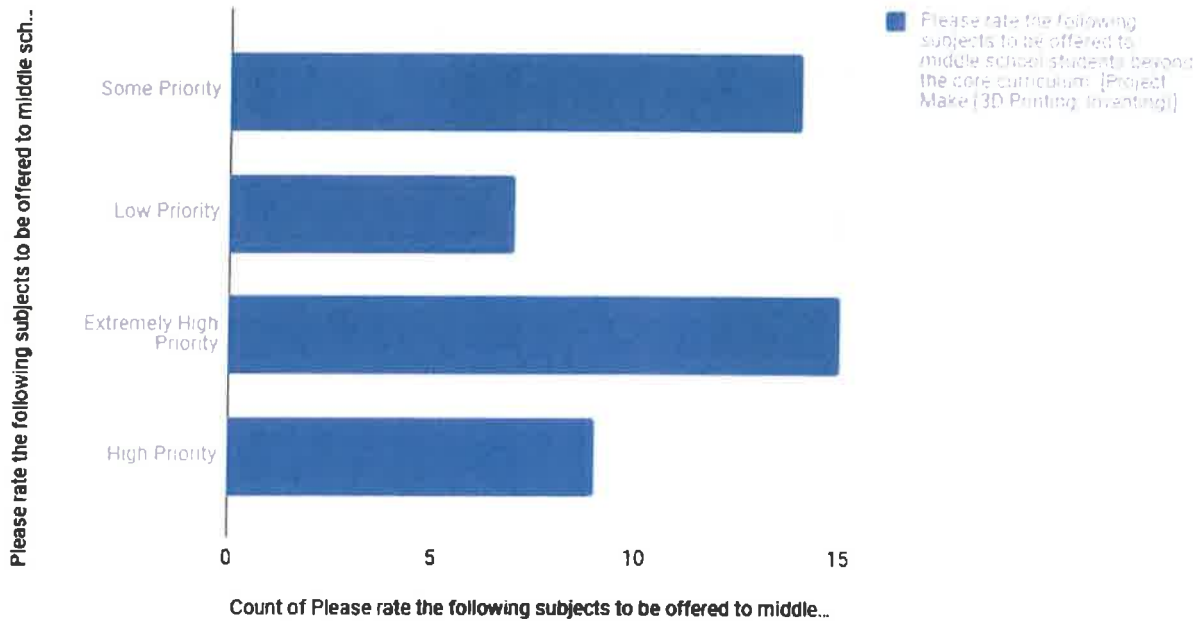

Count of Please rate the following subjects to be offered to middle school students beyond the core curriculum: [Yearbook]

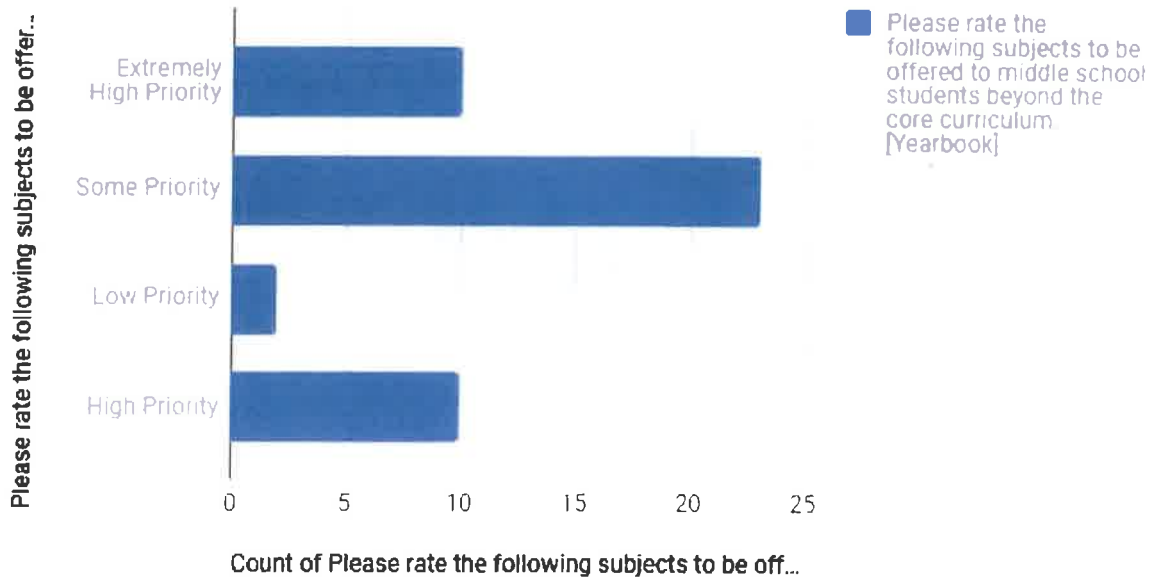

Count of Please rate the following subjects to be offered to middle school students beyond the core curriculum: [Ceramics]

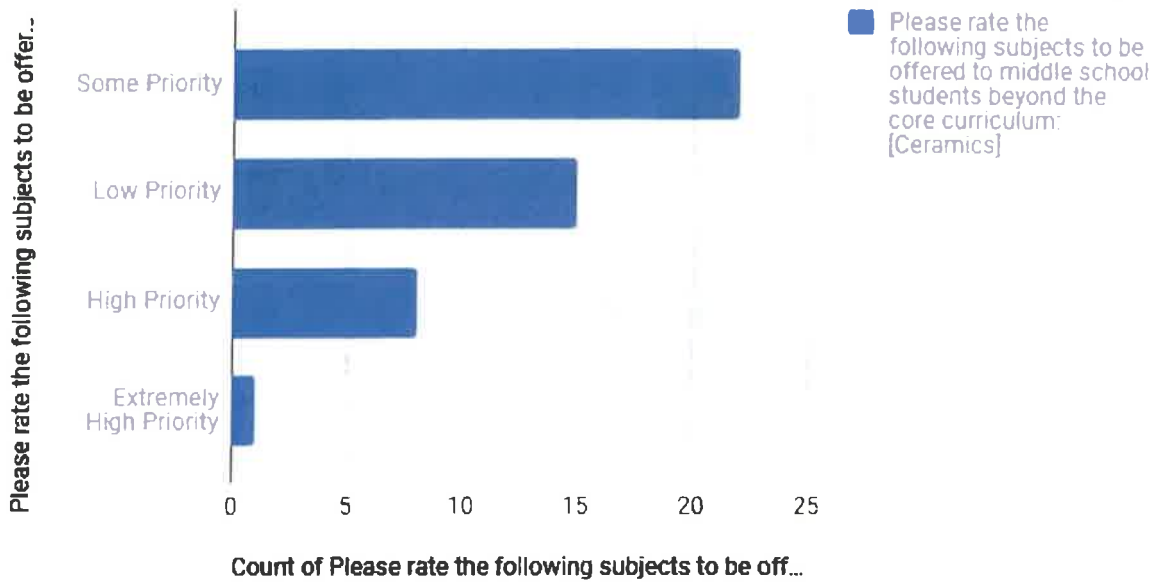

Count of Please rate the following subjects to be offered to middle school students beyond the core curriculum: [Career Exploration (eg CSI, Law)]

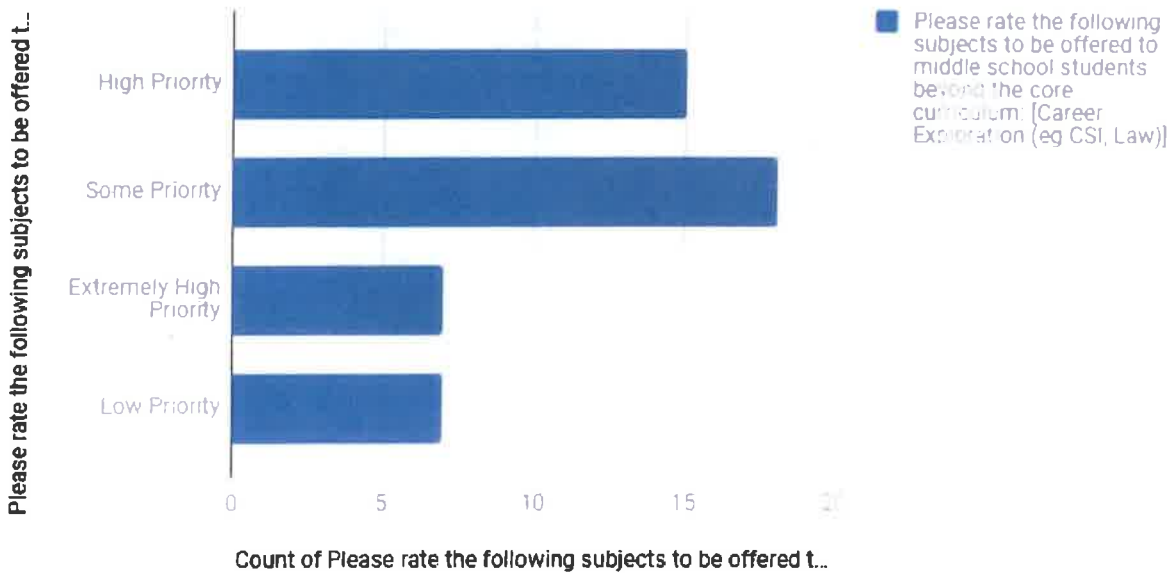

How satisfied are you with what the ENRICH! program currently offers students?

50 responses

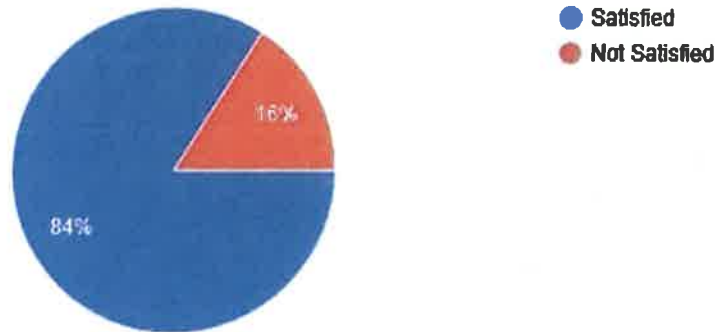

How satisfied are you with what the Traditional program currently offers students?

50 responses

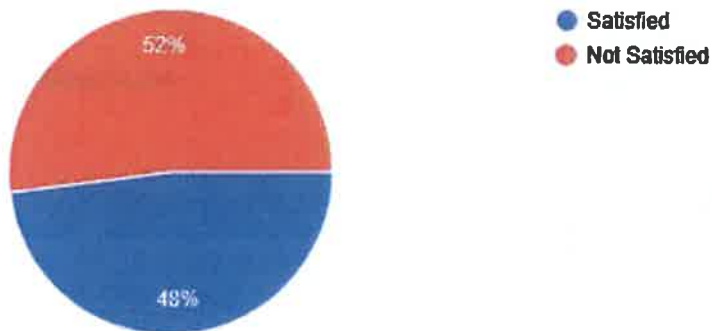

Are you willing to take your 3rd-8th grade students on overnight field trips?

50 responses

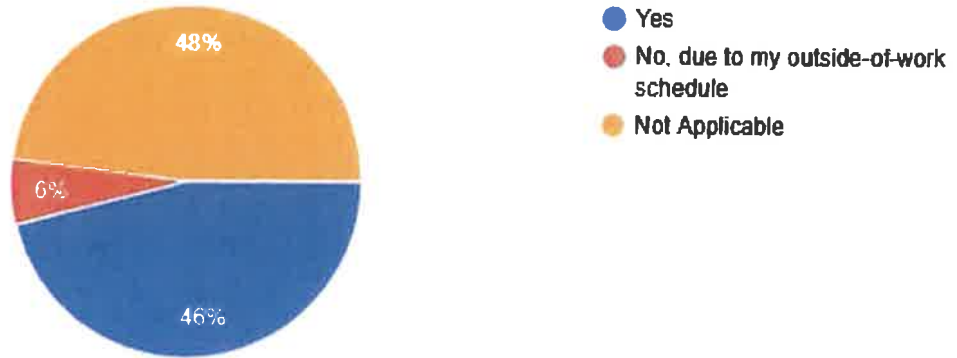

V B

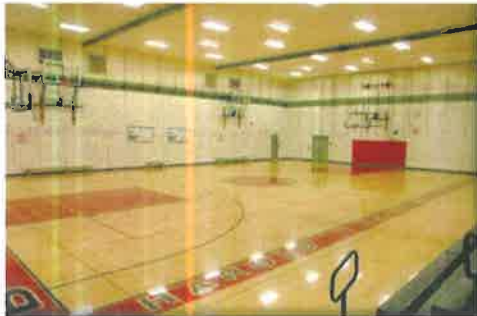

Proposal for:
Gravenstein Union School District

RFP: Proposition 39 Lighting Retrofit

Date Presented: November 19, 2018

Presented by

Kevin Keane
Sales Representative
SYLVANIA Lighting Solutions
kevin.keane@osram.com
(916) 870-8710

Dave Alpert
Regional Sales Manager
SYLVANIA Lighting Solutions
David.alpert@osram.com
(805) 689-3056

Table of Contents

Cover Letter	Page 3
Bid Pricing Detail	Page 4
Approach/Schedule	Page 6
Warranty	Page 6
Supplemental Documents	Page 7
A. Bid Bond and Required Signature Documents	Page 8
B. Specification Sheets	Page 18

November 19, 2018

Brian Sposato
Facilities Manager
Gravenstein Union School District
3840 Twig Avenue
Sebastopol, CA 95472

SYLVANIA Lighting Services Corp, dba SYLVANIA Lighting Solutions (SLS) is pleased to respond to the RFP for Gravenstein Union School District. We would like to express our appreciation for the opportunity to participate in the RFP process. We believe SLS uniquely understands the requirements of the scope of work for the Proposition 39 lighting retrofits at multiple sites.

We are confident that we can fully meet and exceed the requirements of the RFP based on our qualifications and experience, technical approach, implementation approach, proposal pricing and financial strength. We utilize a dedicated management approach and structure to ensure the highest quality for our customers. In response to this RFP, our proposed team brings more than 100 years of combined lighting and electrical experience. We are the largest lighting contractor in the country with over 12 office locations nation-wide. We are confident that we can meet and exceed your immediate needs and support your future growth better than anyone else in the lighting business.

In closing, we wish to thank all parties evaluating this RFP for the consideration given to SLS during your review.

Sincerely Yours,



Juan Lopez
CFO

200 Ballardvale Street
Wilmington, MA 01887
(978) 570-3000
WWW.OSRAM.COM/LS

Bid Pricing Detail

Gravenstein Unified School District
 Prop 39 Lighting Project RFP
 Attachment 3 - Bid Detail Sheet

Contractor

OSRAM SYLVANIA

Measure/Fixture		Gross Installation Cost (\$/fixt)	Incentive (\$/fixt) ^a	Net Cost (\$/fixt)	Qty	Extended Net Cost (\$)
Measure 1: Interior LED Retrofits						
A	3L or 4L Troffer Retrofit	\$191.50		\$191.50	303	\$58,024.50
B	2L TLED Retrofit	\$113.92		\$113.92	83	\$9,455.36
C	3L TLED Retrofit	\$139.79		\$139.79	10	\$1,397.90
D	Not Used	\$97.16		\$97.16	8	\$777.28
E	LED Highbay Fixture	\$640.95		\$640.95	24	\$15,382.80
F	LED Screw In Lamp	\$28.07		\$28.07	4	\$112.28
G	2 CF13TT to LED Retrofit	\$90.82		\$90.82	4	\$363.28
H	50W MH to LED Retrofit	\$227.66		\$227.66	4	\$910.64
Subtotal, Measure 1						\$86,424.04
Measure 2: Exterior LED Retrofits						
AA	LED Wallpack (70W HPS equivalent)	\$563.45		\$563.45	5	\$2,817.25
BB	LED Flood (100W MH Equivalent)	\$245.91		\$245.91	23	\$5,655.93
CC	LED Flood (250W MH Equivalent) w/ photocell	\$326.24		\$326.24	1	\$326.24
DD	LED Wallpack (70W HPS equivalent), Relocated	\$989.27		\$989.27	1	\$989.27
EE	LED Pole Retrofit	\$831.24		\$831.24	2	\$1,662.48
FF	Decorative LED Wallpack	\$227.66		\$227.66	10	\$2,276.60
GG	LED Recessed Undercave	\$43.34		\$43.34	25	\$1,083.50
Allowance - Owners Allowance						\$5,000.00
Subtotal, Measure 2						\$19,811.27
Total Bid Price						\$106,235.31

Notes:

1. This form must be submitted electronically with proposal in excel format, and must match the bid price on the bid sheet.
2. Grey cells indicate entry fields
3. Enter incentive only if contractor will process incentive and directly discount installation price to District. If contractor does not offer this service, enter \$0 and District will apply for incentives.
4. Cells not intended to be edited are protected to avoid accidental changes. Contact the RFP contacts if access is required.

Exclusions & Stipulations

- Quoted pricing assumes 1 for 1 replacement only based on RFP counts, any change in layout or unforeseen electrical issues are not included in the pricing
- Electrical repairs, replacement, rework or modifications beyond the initial fixture connection are expressly excluded unless noted in RFP
- Any change in proposed quantities or recommendations will require a revision to the quote
- Any required permits or associated fees are not included in the quoted pricing
- Asbestos/leaking PCBs/Lead removal is not included in the quoted price above and will need to be removed by a qualified contractor if encountered
- Pricing excludes all applicable taxes
- Attic stock or material to be left onsite after the job has been completed is not included in the quoted pricing
- Pre/post M&V services are not included in the quoted pricing
- Pricing assumes reasonable access to all fixtures
- Quote excludes scaffolding
- Post award audit/re-design services (CAD drawings/reflective ceiling plans/stamped electrical drawings) are not included in the quoted pricing
- New lens replacements and sockets are not included in the quoted pricing and will be handled via change order if required
- Quoted pricing assumes universal voltage (120/277). If 480V is needed, a revision to the quote will be required
- Emergency drivers/ballast are expressly excluded
- This quote excludes the upgrade of pre-existing conditions to meet current code requirements
- Due to frequently changing rebate programs, rebate estimates will need to be verified post award of project and pre-installation
- Pricing is valid for 90 days
- Quoted pricing does not include Title 24 compliance, permits, stamped drawings, fees or acceptance testing
- Quoted pricing excludes rebate administration services by SLS

Approach/Schedule

Estimated time frame from notice to proceed is 10 weeks with the following breakdown:

Mobilization/Material Lead time: 6 weeks

Construction: 3 weeks

Punchlist/Project Closeout & Sign off: 1 week

Sylvania Lighting Solutions (SLS) will submit a schedule detailing the scope of work, area included, and time frame. Hours of installation will be after normal business hours. Implementation to be done in accordance with investment grade audit.

Work to be performed and coordinated by local office (Sacramento). All debris created by retrofit will be removed from site. SLS will provide used lamp and ballast recycling. Manifests and certificates can be provided on request. Equipment utilized for installation will/may include the following: 6', 8', & 10' ladders, scaffolding, scissor lifts. Access to site by contract personnel will be via company and employee vehicles. Contractor will coordinate with customer on access and parking available. Availability of staging areas will be coordinated with customer. SLS representatives will be wearing uniforms for identification and public safety. Work areas will be identified and as necessary marked off as applicable to prevent public access.

Project Management Approach

SYLVANIA has a wealth of experience managing projects large and small. The benefit of a truly national footprint has enabled us to work on just about every type of facility from city halls, to sports arenas, to seventy story office towers and million square foot manufacturing plants. This experience has enabled us to perfect a strong project management style and approach that uses a multi-level approach to successful project execution. SYLVANIA operates a group of National Project Managers, experienced, battle tested specialists who become the single point of contact for the customer.

The Project Manager is supported from above and below to help maintain a strong connection to all job actions and the use of specialized team members to focus expertise where its best put to work. A key member of this management team is our Subcontractor Manager. SYLVANIA uses a network of pre-qualified external partners to perform the labor to install the majority of the project scopes. As a national provider of lighting services, we have found that it is more efficient to maintain a strong network of quality construction partners than it is to try to maintain a top class installation arm from city to city.

Crews are supervised by Project Foreman who are the eyes and ears of SYLVANIA on the job site. They report directly to the project manager and will be responsible for ensuring quality work, clear access, cleanliness and daily reporting of progress. The following are some of the Teams we will be deploying for this project.

Warranty

SYLVANIA agrees to include in the contract (a) a two (2) year warranty for all labor, and a five (5) year warranty for all materials, with the warranty commencing on the date of completion as indicated in the project's Notice of Completion.

Supplemental Documents:

Bid Bond
Specification Sheets

BID BOND

We, the Contractor, Sylvania Lighting Services Corp. as principal ("Principal"), and Federal Insurance Company, as surety ("Surety"), are firmly bound unto the ^{Gravenstein} _{Union School} District ("District") in the penal sum of ten percent (10%) of the total amount of the bid of the Principal submitted to the District for the work described below for the payment of which sum in lawful money of the United States, we bind ourselves, our heirs, executors, administrators, successors and assigns, jointly and severally, firmly by this agreement.

Whereas, the Principal has submitted the accompanying bid ("Bid") dated November 19, 2018, for the following project ("Project"): Prop 39 Lighting Retrofit

Now, therefore, if the Principal does not withdraw its Bid within the period specified, and if the Principal is awarded the Contract and within the period specified fails to enter into a written contract with District, in accordance with the Bid as accepted, or fails to provide the proof of required insurance, the performance bond and/or the payment bond by an admitted surety within the time required, or in the event of unauthorized withdrawal of the Bid, if the Principal pays the District the difference between the amount specified in the Bid and the amount for which District may otherwise procure the required work and/or supplies, if the latter amount is in excess of the former, together with all related costs incurred by District, then the above obligation shall be void and of no effect. Otherwise, the Principal and Surety shall pay to the District the penal sum described above as liquidated damages.

Surety, for value received, hereby agrees that no change, extension of time, alteration or addition to the term of the Contract or the call for bids, or to the work to be performed thereunder, or the Specifications accompanying the same, shall in any way affect its obligation under this bond, and it does hereby waive notice of any such change, extension of time, alteration or addition.

In witness whereof the above-bound parties have executed this instrument under their several seals this 14th day of November, 2018, the name and corporate seal of each corporate Party being hereunder affixed and these presents duly signed by its undersigned representative, pursuant to the authority of its governing body.

(Corporate Seal)

Sylvania Lighting Services Corp.

Principal/Contractor

By



Title:

Chief Financial Officer

(Corporate Seal)

Federal Insurance Company

Surety

Attach Attorney-In-Fact Certificate

By  _____
Jessica Iannotta, Attorney-in-Fact
Title

To be signed by Principal and Surety and Acknowledgment and Notary Seal to be attached.

CALIFORNIA ALL- PURPOSE CERTIFICATE OF ACKNOWLEDGMENT

A notary public or other officer completing this certificate verifies only the identity of the individual who signed the document to which this certificate is attached, and not the truthfulness, accuracy, or validity of that document.

State of _____ }

County of _____ }

On _____ before me, _____, Notary Public
(Here insert name and title of the officer)

personally appeared _____,
who proved to me on the basis of satisfactory evidence to be the person(s) whose name(s) is/are subscribed to the within instrument and acknowledged to me that he/she/they executed the same in his/her/their authorized capacity(ies), and that by his/her/their signature(s) on the instrument the person(s), or the entity upon behalf of which the person(s) acted, executed the instrument.

I certify under PENALTY OF PERJURY under the laws of the State of California that the foregoing paragraph is true and correct.

WITNESS my hand and official seal.

Notary Public Signature (Notary Public Seal)
My Commission Expires: _____

ADDITIONAL OPTIONAL INFORMATION

DESCRIPTION OF THE ATTACHED DOCUMENT

(Title or description of attached document)

(Title or description of attached document continued)

Number of Pages _____ Document Date _____

CAPACITY CLAIMED BY THE SIGNER

- Individual (s)
 Corporate Officer

(Title)

- Partner(s)
 Attorney-in-Fact
 Trustee(s)
 Other _____

INSTRUCTIONS FOR COMPLETING THIS FORM

This form complies with current California statutes regarding notary wording and, if needed, should be completed and attached to the document. Acknowledgments from other states may be completed for documents being sent to that state so long as the wording does not require the California notary to violate California notary law.

- State and County information must be the State and County where the document signer(s) personally appeared before the notary public for acknowledgment.
- Date of notarization must be the date that the signer(s) personally appeared which must also be the same date the acknowledgment is completed.
- The notary public must print his or her name as it appears within his or her commission followed by a comma and then your title (notary public).
- Print the name(s) of document signer(s) who personally appear at the time of notarization.
- Indicate the correct singular or plural forms by crossing off incorrect forms (i.e. ~~he/she/they~~, is /are) or circling the correct forms. Failure to correctly indicate this information may lead to rejection of document recording.
- The notary seal impression must be clear and photographically reproducible. Impression must not cover text or lines. If seal impression smudges, re-seal if a sufficient area permits, otherwise complete a different acknowledgment form.
- Signature of the notary public must match the signature on file with the office of the county clerk.
 - ❖ Additional information is not required but could help to ensure this acknowledgment is not misused or attached to a different document.
 - ❖ Indicate title or type of attached document, number of pages and date.
 - ❖ Indicate the capacity claimed by the signer. If the claimed capacity is a corporate officer, indicate the title (i.e. CEO, CFO, Secretary).
- Securely attach this document to the signed document with a staple.

CALIFORNIA ALL-PURPOSE CERTIFICATE OF ACKNOWLEDGMENT

A notary public or other officer completing this certificate verifies only the identity of the individual who signed the document to which this certificate is attached, and not the truthfulness, accuracy, or validity of that document.

State of NJ }

County of Morris }

On 11/14/2018 before me, April Perez, Notary Public
(Here insert name and title of the officer)

personally appeared Jessica Iannotta
who proved to me on the basis of satisfactory evidence to be the person(s) whose name(s) is/~~are~~ subscribed to the within instrument and acknowledged to me that he/~~she/they~~ executed the same in his/~~her/their~~ authorized capacity(ies), and that by his/~~her/their~~ signature(s) on the instrument the person(s), or the entity upon behalf of which the person(s) acted, executed the instrument.

I certify under PENALTY OF PERJURY under the laws of the State of California that the foregoing paragraph is true and correct.

WITNESS my hand and official seal.



April Perez
Notary Public Signature
My Commission Expires: 4/16/2019

(Notary Public Seal)

ADDITIONAL OPTIONAL INFORMATION

DESCRIPTION OF THE ATTACHED DOCUMENT

(Title or description of attached document)

(Title or description of attached document continued)

Number of Pages _____ Document Date _____

CAPACITY CLAIMED BY THE SIGNER

- Individual (s)
 Corporate Officer

(Title)
 Partner(s)
 Attorney-in-Fact
 Trustee(s)
 Other _____

INSTRUCTIONS FOR COMPLETING THIS FORM

This form complies with current California statutes regarding notary wording and, if needed, should be completed and attached to the document. Acknowledgments from other states may be completed for documents being sent to that state so long as the wording does not require the California notary to violate California notary law.

- State and County information must be the State and County where the document signer(s) personally appeared before the notary public for acknowledgment.
- Date of notarization must be the date that the signer(s) personally appeared which must also be the same date the acknowledgment is completed.
- The notary public must print his or her name as it appears within his or her commission followed by a comma and then your title (notary public).
- Print the name(s) of document signer(s) who personally appear at the time of notarization.
- Indicate the correct singular or plural forms by crossing off incorrect forms (i.e. he/~~she/they~~, is /~~are~~) or circling the correct forms. Failure to correctly indicate this information may lead to rejection of document recording.
- The notary seal impression must be clear and photographically reproducible. Impression must not cover text or lines. If seal impression smudges, re-seal if a sufficient area permits, otherwise complete a different acknowledgment form.
- Signature of the notary public must match the signature on file with the office of the county clerk.
 - ❖ Additional information is not required but could help to ensure this acknowledgment is not misused or attached to a different document.
 - ❖ Indicate title or type of attached document, number of pages and date.
 - ❖ Indicate the capacity claimed by the signer. If the claimed capacity is a corporate officer, indicate the title (i.e. CEO, CFO, Secretary).
- Securely attach this document to the signed document with a staple.

Power of Attorney

Federal Insurance Company | Vigilant Insurance Company | Pacific Indemnity Company

Know All by These Presents, That FEDERAL INSURANCE COMPANY, an Indiana corporation, VIGILANT INSURANCE COMPANY, a New York corporation, and PACIFIC INDEMNITY COMPANY, a Wisconsin corporation, do each hereby constitute and appoint Kristin S. Bender, Jessica Iannotta, Annette M. Leuschner, Kelly O'Malley and April D. Perez of Morristown, New Jersey; Megan Schlueter of Raleigh, North Carolina-----

each as their true and lawful Attorney-in-Fact to execute under such designation in their names and to affix their corporate seals to and deliver for and on their behalf as surety thereon or otherwise, bonds and undertakings and other writings obligatory in the nature thereof (other than bail bonds) given or executed in the course of business, and any instruments amending or altering the same, and consents to the modification or alteration of any instrument referred to in said bonds or obligations.

In Witness Whereof, said FEDERAL INSURANCE COMPANY, VIGILANT INSURANCE COMPANY, and PACIFIC INDEMNITY COMPANY have each executed and attested these presents and affixed their corporate seals on this 21st day of August, 2018.

Dawn M. Chloros

Dawn M. Chloros, Assistant Secretary

Stephen M. Haney

Stephen M. Haney, Vice President



STATE OF NEW JERSEY

County of Hunterdon

SS.

On this 21st day of August, 2018, before me, a Notary Public of New Jersey, personally came Dawn M. Chloros, to me known to be Assistant Secretary of FEDERAL INSURANCE COMPANY, VIGILANT INSURANCE COMPANY, and PACIFIC INDEMNITY COMPANY, the companies which executed the foregoing Power of Attorney, and the said Dawn M. Chloros, being by me duly sworn, did depose and say that she is Assistant Secretary of FEDERAL INSURANCE COMPANY, VIGILANT INSURANCE COMPANY, and PACIFIC INDEMNITY COMPANY and knows the corporate seals thereof, that the seals affixed to the foregoing Power of Attorney are such corporate seals and were thereto affixed by authority of said Companies; and that she signed said Power of Attorney as Assistant Secretary of said Companies by like authority; and that she is acquainted with Stephen M. Haney, and knows him to be Vice President of said Companies; and that the signature of Stephen M. Haney, subscribed to said Power of Attorney is in the genuine handwriting of Stephen M. Haney, and was thereto subscribed by authority of said Companies and in deponent's presence.

Notarial Seal



KATHERINE J. ADELAAR
NOTARY PUBLIC OF NEW JERSEY
No. 2318886
Commission Expires July 16, 2019

Katherine J. Adelaar
Notary Public

CERTIFICATION

Resolutions adopted by the Boards of Directors of FEDERAL INSURANCE COMPANY, VIGILANT INSURANCE COMPANY, and PACIFIC INDEMNITY COMPANY on August 30, 2016:

"RESOLVED, that the following authorizations relate to the execution, for and on behalf of the Company, of bonds, undertakings, recognizances, contracts and other written commitments of the Company entered into in the ordinary course of business (each a "Written Commitment"):

- (1) Each of the Chairman, the President and the Vice Presidents of the Company is hereby authorized to execute any Written Commitment for and on behalf of the Company, under the seal of the Company or otherwise.
- (2) Each duly appointed attorney-in-fact of the Company is hereby authorized to execute any Written Commitment for and on behalf of the Company, under the seal of the Company or otherwise, to the extent that such action is authorized by the grant of powers provided for in such person's written appointment as such attorney-in-fact.
- (3) Each of the Chairman, the President and the Vice Presidents of the Company is hereby authorized, for and on behalf of the Company, to appoint in writing any person the attorney-in-fact of the Company with full power and authority to execute, for and on behalf of the Company, under the seal of the Company or otherwise, such Written Commitments of the Company as may be specified in such written appointment, which specification may be by general type or class of Written Commitments or by specification of one or more particular Written Commitments.
- (4) Each of the Chairman, the President and the Vice Presidents of the Company is hereby authorized, for and on behalf of the Company, to delegate in writing to any other officer of the Company the authority to execute, for and on behalf of the Company, under the Company's seal or otherwise, such Written Commitments of the Company as are specified in such written delegation, which specification may be by general type or class of Written Commitments or by specification of one or more particular Written Commitments.
- (5) The signature of any officer or other person executing any Written Commitment or appointment or delegation pursuant to this Resolution, and the seal of the Company, may be affixed by facsimile on such Written Commitment or written appointment or delegation.

FURTHER RESOLVED, that the foregoing Resolution shall not be deemed to be an exclusive statement of the powers and authority of officers, employees and other persons to act for and on behalf of the Company, and such Resolution shall not limit or otherwise affect the exercise of any such power or authority otherwise validly granted or vested."

I, Dawn M. Chloros, Assistant Secretary of FEDERAL INSURANCE COMPANY, VIGILANT INSURANCE COMPANY, and PACIFIC INDEMNITY COMPANY (the "Companies") do hereby certify that

- (i) the foregoing Resolutions adopted by the Board of Directors of the Companies are true, correct and in full force and effect,
- (ii) the foregoing Power of Attorney is true, correct and in full force and effect.

Given under my hand and seals of said Companies at Whitehouse Station, NJ, this November 14, 2018.



Dawn M. Chloros

Dawn M. Chloros, Assistant Secretary

IN THE EVENT YOU WISH TO VERIFY THE AUTHENTICITY OF THIS BOND OR NOTIFY US OF ANY OTHER MATTER, PLEASE CONTACT US AT:

Telephone (908) 903-3493 Fax (908) 903-3656 e-mail: surety@chubb.com

FEDERAL INSURANCE COMPANY

STATEMENT OF ASSETS, LIABILITIES AND SURPLUS TO POLICYHOLDERS

Statutory Basis

DECEMBER 31, 2017

(in thousands of dollars)

<i>ASSETS</i>		<i>LIABILITIES AND SURPLUS TO POLICYHOLDERS</i>	
Cash and Short Term Investments.....	\$ (78,340)	Outstanding Losses and Loss Expenses	\$ 10,545,326
United States Government, State and Municipal Bonds	7,063,387	Unearned Premiums.....	2,087,124
Other Bonds.....	5,366,068	Ceded Reinsurance Premiums Payable.....	739,431
Stocks	134,041	Provision for Reinsurance	57,140
Other Invested Assets.....	1,006,599	Other Liabilities.....	<u>1,044,341</u>
TOTAL INVESTMENTS	<u>13,491,755</u>	TOTAL LIABILITIES	<u>14,473,362</u>
Investments in Affiliates:		Capital Stock.....	20,980
Chubb Investment Holdings, Inc.....	3,890,677	Paid-In Surplus.....	3,209,193
Great Northern Insurance Company	557,388	Unassigned Funds	<u>4,066,505</u>
Vigilant Insurance Company.....	327,316		
Chubb Indemnity Insurance Company.....	171,786	SURPLUS TO POLICYHOLDERS.....	<u>7,296,678</u>
Chubb National Insurance Company	171,493		
Chubb European Investment Holdings, SLP .	119,836		
Other Affiliates	76,806		
Premiums Receivable	1,594,780		
Other Assets	<u>1,368,203</u>		
TOTAL ADMITTED ASSETS	<u>\$ 21,770,040</u>	TOTAL LIABILITIES AND SURPLUS	<u>\$ 21,770,040</u>

Investments are valued in accordance with requirements of the National Association of Insurance Commissioners. At December 31, 2017, investments with a carrying value of \$558,430,596 were deposited with government authorities as required by law.

State, County & City of New York, — ss:

Dawn M. Chloros, Assistant Secretary _____ of the Federal Insurance Company

being duly sworn, deposes and says that the foregoing Statement of Assets, Liabilities and Surplus to Policyholders of said Federal Insurance Company on December 31, 2017 is true and correct and is a true abstract of the Annual Statement of said Company as filed with the Secretary of the Treasury of the United States for the 12 months ending December 31, 2017.

Subscribed and sworn to before me
this March 1, 2018.

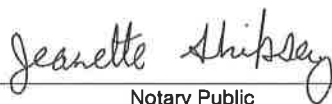
Notary Public

Assistant Secretary

JEANETTE SHIPSEY
Notary Public, State of New York
No. 02SH5074142
Qualified in Nassau County
Commission Expires March 10, 2019

BID PROPOSAL FORM

Governing Board
Gravenstein Union School District

Dear Members of the Governing Board:

The undersigned, doing business under the name of SYLVANIA Lighting Solutions Corp., having carefully examined the location of the proposed work, the local conditions of the place where the work is to be done, the Notice Inviting Bids, the General Conditions, the Instructions to Bidders, the Plans and Specifications, and all other Contract Documents for the proposed Proposition 39 Lighting Project ("Project"), proposes to perform all work and activities in accordance with the Contract Documents, including all of its component parts, and to furnish all required labor, materials, equipment, transportation and services required for the construction of the Project in strict conformity with the Contract Documents, including the Plans and Specifications, as follows:

BASE BID:

For the sum of

One-Hundred, Six-Thousand, Two-Hundred, Thirty-Five Dollars and Thirty-One Cents
Dollars (\$ 106,235.31).

ADDITIVE/DEDUCTIVE ALTERNATE [if applicable]:

Additive/Deductive Alternate #1 _____
Add/Subtract _____ Dollars (\$ _____)

Additive/Deductive Alternate #2 _____
Add/Subtract _____ Dollars (\$ _____)

Additive/Deductive Alternate #3 _____
Add/Subtract _____ Dollars (\$ _____)

The undersigned has checked carefully all the above figures and understands that the District is not responsible for any errors or omissions on the part of the undersigned in making this bid.

Enclosed find certified or cashier's check no. _____ of the
_____ Bank for _____
Dollars (\$ _____) or Bidder's Bond of the Federal Insurance Company surety company
in an amount of not less that ten percent (10%) of the entire bid. The undersigned further agrees,
on the acceptance of this proposal, to execute the Contract and provide the required bonds and
insurance and that in case of default in executing these documents within the time fixed by the

Contract Documents, the proceeds of the check or bond accompanying this bid shall be forfeited and shall become the property of the District.

Contractor agrees to commence the work within the time specified in the Notice to Proceed. It is understood that this bid is based upon completing the work within the number of calendar days specified in the Contract Documents.

ADDENDA:

Receipt of the following addenda is hereby acknowledged:

Addendum #1	Dated 10/2018	Addendum # _____	Dated: _____
Addendum #2	Dated: 11/9/2018	Addendum # _____	Dated: _____
Addendum _____	Dated: _____	Addendum # _____	Dated: _____

Respectfully submitted,

Company: SYLVANIA Lighting Services, Corp. dba SYLVANIA Lighting Solutions

Address: 200 Ballardvale Street

Wilmington, MA 01887

By: Juan Lopez
(Please Print Or Type)

Signature:  _____

Title: CFO

Date: 11/15/2018

Telephone: 978-570-3000

Contractor's License No: 317264 Class C-10, B Expiration Date 8/31/2020

- Required Attachments:
- Subcontractor List Form
 - Non-Collusion Declaration
 - Bid Bond (or Cashier's or Certified Check)
 - Workers' Compensation Certificate

SUBCONTRACTOR LIST FORM

Each bidder shall list below the name and location of place of business for each Subcontractor who will perform a portion of the Contract work in an amount in excess of 1/2 of 1 percent of the total contract price. The nature of the work to be subcontracted shall also be described.

DESCRIPTION OF WORK	NAME	LOCATION	LICENSE #
<i>Self Perform</i>			

WORKERS' COMPENSATION CERTIFICATE

Labor Code §3700 in relevant part provides:

"Every employer except the State shall secure the payment of compensation in one or more of the following ways:

- (a) By being insured against liability to pay compensation in one or more insurers duly authorized to write compensation insurance in this State.
- (b) By securing from the Director of Industrial Relations a certificate of consent to self-insure, which may be given upon furnishing proof satisfactory to the Director of Industrial Relations of ability to self-insure and to pay any compensation that may become due to his employees."

I am aware of the provisions of §3700 of the Labor Code which require every employer to be insured against liability for workers' compensation or to undertake self-insurance in accordance with the provisions of that Code, and I will comply with such provisions before commencing the performance of the work of this Contract and will require all Subcontractors to do the same.

SYLVANIA Lighting Services Corp., dba SYLVANIA Lighting Solutions
Contractor

By: _____

In accordance with Article 5 (commencing at §1860), Chapter 1, Part 7, Division 2 of the Labor Code, the above certificate must be signed and filed with the awarding body prior to performing any work under this Contract.

PL V 16.5W BYP

TITANIUM LED SERIES



PL:EDGE
SERIES

16.5W REPLACES

42W
CFL

60% Energy Savings

PRO



- High output 1900lm
- Built-in universal voltage driver - Bypass installation
- Compatible with G24d, GX24d, G24q & GX24q sockets
- Innovative round design
- Exceptional efficacy 115 LPW
- Available in 3000K, 3500K & 4000K CCT



50,000 H



UNIVERSAL

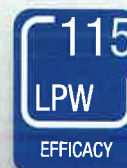

EFFICACY



WARRANTY

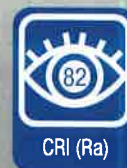

CRI (Ra)



SEMI DIRECTIONAL



DESIGNED FOR VERTICAL APPLICATIONS



PL V 16.5W BYP TITANIUM LED SERIES



APPLICATIONS

Retail



Hospitality

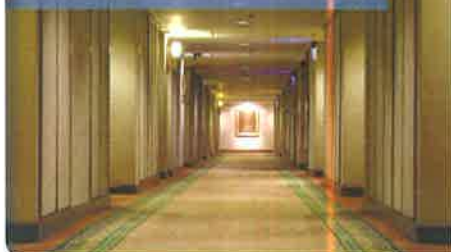

Office



- Base:** G24d, GX24d, G24q & GX24q (2/4-pin CFL)
- Voltage:** 120-277V
- Dimmable:** No
- PF:** 0.9
- Lifetime (L70):** 50,000 hrs
- Weight:** 0.66lb / 301g

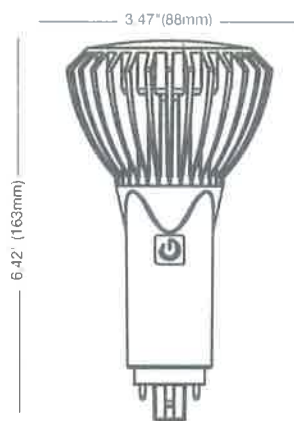

SPECIFICATIONS

Model	Product	Power (W)	CCT	CRI (typ.)	Lumens	LPW	Beam Angle
16.5PLV/830/BYP	98256	16.5	Warm White 3000K	82	1800	109	120°
16.5PLV/835/BYP	98257	16.5	Neutral White 3500K	82	1850	112	120°
16.5PLV/840/BYP	98258	16.5	Cool White 4000K	82	1900	115	120°

* Suitable for damp locations. Not for use where directly exposed to weather or water.
 ** Not intended for use in enclosed fixtures.

ECHB44Q ThermaLED Technology

ThermaLED Bentley 16" LED Highbay



12802 COMMODITY PL
TAMPA, FL 33626
PHONE: 844-636-2036
SALES@ECO-REVOLUTION.COM
WWW.ECO-REVOLUTION.COM

Order Information Example:

ECHB44QF1X169U5KGWSP

ECHB44Q F 1X169

Model	Optics	Wattage	Driver	CCT	Lens	Color	Options
ECHB44Q=ThermaLED Bentley 16" LED Highbay	F=Wide	1X169=169w	U=120-277V H=347-480V	4K=4000K 5K=5000K	G=Clear Flat Glass Lens C=Acrylic Conical Lens D=Acrylic Drop Lens B=Polycarbonate Drop Lens	W=White C=Custom (Consult Factory)	SF=Single Fuse DF=Double Fuse SP=Surge Protection M3= Microwave Sensor for Mounting Heights of 20 Feet or Above C6300W=6 Foot White Cord, 300VAC, 3 Wire, Leads CP6120W=6 Foot White Cord, 3 Wire, L5-15P Twist-Lock Plug CP6277W=6 Foot White Cord, 3 Wire, L7-15P Twist-Lock Plug C6600B=6 Foot Black Cord, Type STW, 600VAC, 3 Wire, Leads

The Eco-Revolution ThermaLED Bentley 16" Highbay is available with a choice of four lenses designed to replace HID lighting systems up to 400w MH. Typical high bay lighting applications include warehouses, manufacturing facilities, gymnasiums, indoor sports facilities, and retail and big box store lighting. Suitable for 16 to 30 foot mounting heights based on light level and uniformity requirements.



Microwave Sensor Factory Installed "M3" Option

L70
(25°C) **302,000 Hours**

Specifications and Features:

Housing:	Die Cast Aluminum Housing with External Heat Sinks for Cooler Operating Temperatures. Includes 4" Stem. Maximum Stem Length: 30 Feet.
Listing & Ratings:	CSA: Listed for Damp Locations, ANSI/UL 1598, 8750 (Lens Gasket Use Required.) IP65 Sealed LED Compartment.
Finish:	White Powdercoat Finish Over a Chromate Conversion Coating. Custom Colors Available Upon Request.
Lens:	Tempered Clear Flat Glass Lens, Polycarbonate Drop Lens, Acrylic Drop Lens, Acrylic Conical Lens.
Mounting Options:	Mount with Included 3/4" Die Cast Hook.
ThermaLED LED:	Aluminum Boards
Wattage:	Array: 169w; System: 178.5w; (400w HID Equivalent)
Driver:	Electronic Driver, 120-277V, 50/60Hz or 347-480V, 50/60Hz; Less Than 20% THD and PF>0.90. Standard Internal Surge Protection 6kV. 0-10V Dimming Standard for a Dimming Range of 100% to 10%; Dimming Source Current is 150 Microamps.
Controls:	Fixtures Ordered with Factory-Installed Photocell or Motion Sensor Controls are Internally Wired for Switching and/or 1-10V Dimming Within the Housing. Remote Direct Wired Interface of 1-10V Dimming is Not Implied and May Not Be Available. Please Consult Factory. Fixtures are Tested with Eco-Revolution Controls and May Not Function Properly With Controls Supplied By Others. Fixtures are NOT Designed for Use with Line Voltage Dimmers.
Warranty:	5-Year Warranty for -40°C to +50°C Environment

See Page 3 for Projected Lumen Maintenance Table.

Certification & Listings:



DesignLights Consortium™
Qualified Luminaire:
ECHB44QF1X169[U H]5KG**

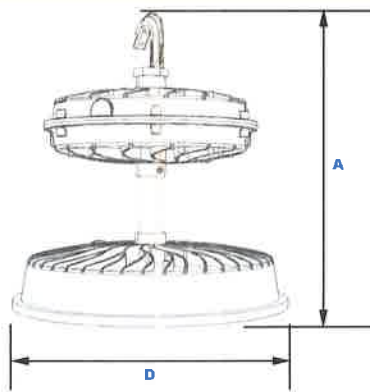

Dimensions

Diameter (D)	16 3/4" (413mm)
Height (A)	16 3/4" (413mm)

Project Information:

Project Name:

Fixture Type:

Complete Catalog #:

Date:

Comments:

5 LOCATIONS
Tampa, FL
Vancouver, WA
Cerritos, CA
Walden, NY
Memphis, TN

Specifications subject to change without notice. Rev. 081418

ECHB44Q **ThermaLED** echnology

ThermaLED Bentley 16" LED Highbay



12802 COMMODITY PL
TAMPA, FL 33626
PHONE: 844-636-2036
SALES@ECO-REVOLUTION.COM
WWW.ECO-REVOLUTION.COM

Lens Options:



ECHB44Q Shown with Tempered Clear Flat Glass Lens (G)



ECHB44Q Shown with Acrylic Conical Lens (C)



ECHB44Q Shown with Acrylic Drop Lens (D)



ECHB44Q Shown with Polycarbonate Drop Lens (B)

Accessories & Replacement Parts:



ECHB44WG



ECP17116

Accessories (Order Separately, Field Installed)

ECHB44WG Wire Guard, Fits ECHB44, for Use with Flat Glass Lenses.

Replacement Parts (Order Separately, Field Installed)

ECHBGL16	16" Tempered Clear Flat Glass Lens
ECHBCL16	16" LexaLite Clear Prismatic Acrylic Conical Lens. UV Stabilized, High-Efficiency Operation In General Applications.
ECHBDL16	16" LexaLite Clear Prismatic Acrylic Drop Lens. UV Stabilized, High-Efficiency Operation In General Applications.
ECHBPC16	16" Polycarbonate Drop Lens.
ECHBCB16	16" Clampband
ECCPMH1	Die Cast Hook with 3/4" NPS Threads
ECP17116	Microwave Sensor for Mounting Heights of 20 Feet or Above.

ECHB44Q ThermaLED technology

ThermaLED Bentley 16" LED Highbay



12802 COMMODITY PL
TAMPA, FL 33626
PHONE: 844-636-2036
SALES@ECO-REVOLUTION.COM
WWW.ECO-REVOLUTION.COM

Photometric Data

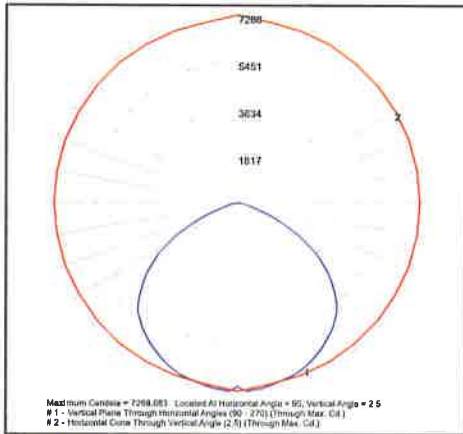

ECHB44QF1X169U5KG - Clear Glass Lens

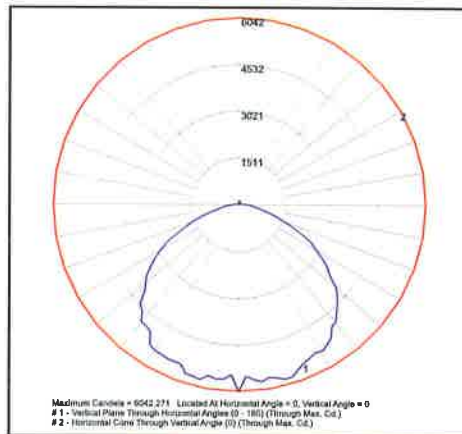

ECHB44QF1X169U5KG - Conical Lens

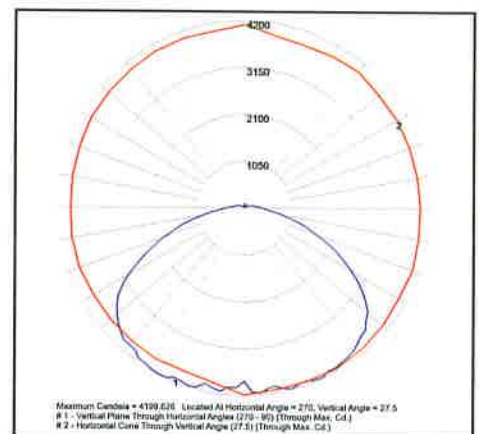

ECHB44QF1X169U5KG - Drop Lens

Photometric Performance

LED Board Watts	Drive Current (mA)	Input Watts	Spacing Criteria	5000 CCT 80 CRI		4000 CCT 80 CRI	
				Lumens	LPW	Lumens	LPW
ThermaLED 169w with Clear Glass (G)	525	179	1.52	19,811	111	19,019	106
ThermaLED 169w with Acrylic Conical Lens (C)			1.36	18,184	102	17,456	98
ThermaLED 169w with Acrylic Drop Lens (D)			1.52	16,442	92	15,784	88

Projected Lumen Maintenance

Data shown for 5000 CCT	Compare to MH						
	TM-21-11	Input Watts	Initial	25,000 Hrs	50,000 Hrs	100,000 Hrs	Calculated L70@ 25°C
L70 Lumen Maintenance @ 25°C / 77°F	TM-21-11	179	1.00	0.98	0.95	0.90	302,000
L70 Lumen Maintenance @ 50°C / 122°F	TM-21-11	179	1.00	0.94	0.88	0.76	124,000
L80 Lumen Maintenance @ 40°C / 104°F	TM-21-11	179	1.00	0.96	0.91	0.83	117,000

- NOTES:**
1. Projected per IESNA TM-21-11. Data references the extrapolated performance projections for the 626mA base model in a 25°C ambient, based on 10,000 hours of LED testing per IESNA LM-80-08.
2. Compare to MH box indicates suggested Light Loss Factor (LLF) to be used when comparing to Metal Halide (MH) systems.

ECPF70Q ThermalLED technology

ThermalLED Reveal Open Small Round Post Top



12802 COMMODITY PL
TAMPA, FL 33626
PHONE: 844-636-2036
SALES@ECO-REVOLUTION.COM
WWW.ECO-REVOLUTION.COM
A QESI COMPANY SINCE 1985

Order Information Example:

ECPF70QF1X84U5KCBS

ECPF70Q

Model	Optics	Wattage	Driver	CCT	Lens	Color	Options
ECPF70Q= ThermalLED Reveal Open Small Round Post Top	C=Type III* F=Type V *37 & 65w Model Only	1X37=37w 1X42=42w 1X65=65w 1X84=84w	U=120-277V H=347-480V	3K=3000K 4K=4000K 5K=5000K	C=Clear Polycarbonate Array Lens L=SoftLED LumaLens Opal Polycarbonate Array Lens	B=Black C=Custom (Consult Factory)	SF=Single Fuse DF=Double Fuse SP=Surge Protection S2=Microwave Sensor with Dimming for Mounting Heights of 8 to 40' R3=3-Pin Twist Lock Photocell Receptacle R7=7-Pin ANSI C136.41—2013 Twist Lock Photocell Receptacle



L70
(25°C) **473,000 Hours**

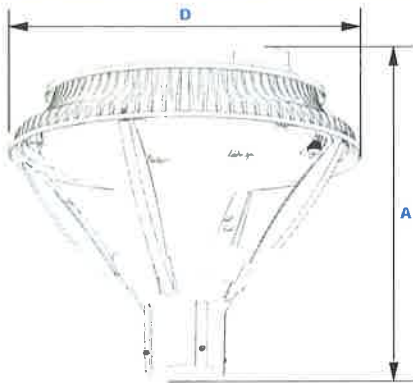

Dimensions

Diameter (D)	16 1/2" (411mm)
Height (A)	14 1/4" (378mm)

Specifications and Features:

Housing:	Die Cast Aluminum Housing, Integral Heat Sinking. Photocell Adaptable.
Listing & Ratings:	CSA: Listed for Wet Locations, ANSI/UL 1598, 8750 IP66 Sealed LED Compartment.
Finish:	Black Powdercoat Finish Over a Chromate Conversion Coating. Custom Colors Available Upon Request
Lens:	Clear Polycarbonate or SoftLED LumaLens Opal Polycarbonate Vandal-Resistant Array Lens to Seal LED Array
Mounting Options:	Accommodates "P3" 2 1/4" O.D. x 3" Tenons
ThermalLED LED:	Aluminum Boards
Wattage:	37w Array: 37w, System: 41w; (70-150w HID Equivalent) 42w Array: 42w, System: 43.2w; (70-150w HID Equivalent) 65w Array: 65.1w, System: 72w; (150-250w HID Equivalent) 84w Array: 84w, System: 86.3w; (150-250w HID Equivalent)
Driver:	Electronic Driver, 120-277V, 50/60Hz or 347-480V, 50/60Hz; Less Than 20% THD and PF>0.90. Standard Internal Surge Protection 6kV. 0-10V Dimming Standard for a Dimming Range of 100% to 10%; Dimming Source Current is 150 Microamps
Controls:	Fixtures Ordered with Factory-Installed Photocell or Motion Sensor Controls are Internally Wired for Switching and/or 1-10V Dimming Within the Housing. Remote Direct Wired Interface of 1-10V Dimming is Not Implied and May Not Be Available, Please Consult Factory. Fixtures are Tested with Eco-Revolution Controls and May Not Function Properly With Controls Supplied By Others. Fixtures are NOT Designed for Use with Line Voltage Dimmers.
Warranty:	5-Year Warranty for -40°C to +50°C Environment.

See Page 2 for Projected Lumen Maintenance Table.

Certification & Listings:



DesignLights Consortium™
Qualified Luminaires:
ECPF70QF1X84[U H]4KC***
ECPF70QF1X84[U H]6KC***



Project Information:

Project Name:	Fixture Type:
Complete Catalog #:	Date:
Comments:	

5 LOCATIONS
Tampa, FL
Vancouver, WA
Cerritos, CA
Walden, NY
Memphis, TN

ECPF70Q **ThermaLED** Technology

ThermaLED Reveal Open Small Round Post Top



12802 COMMODITY PL
TAMPA, FL 33626
PHONE: 844-636-2036
SALES@ECO-REVOLUTION.COM
WWW.ECO-REVOLUTION.COM
A QESI COMPANY SINCE 1985

Accessories & Replacement Parts:



Accessories (Order Separately, Field Installed)	
ECP18131	Twist Lock Non-Shorting (Open) Cap Disconnects Service to Fixture for Temporary or Permanent Disabling (Fixture Always Off). IP65, 480V Maximum.
ECP18132	Twist Lock Shorting Cap Provides Fixed Service to Fixture (Fixture Always on). IP65, Rated Load 7200w Tungsten.
ECP18140	110-120VAC Instant Twist Lock Photocell
ECP18142	105-287VAC Instant Twist Lock Photocell
ECP18150	120VAC Time Delay Twist Lock Photocell
ECP18152	277VAC Time Delay Twist Lock Photocell
ECP18154	480VAC Time Delay Twist Lock Photocell. For 480V use only.
ECP18156	120-277VAC Universal Twist Lock Photocell

Replacement Parts (Order Separately, Field Installed)	
ECPF70ALL	SoftLED LumaLens Opal Polycarbonate Array Lens
ECP17117	Internal Microwave Sensor with Dimming for Mounting Heights of 8 to 40'. 120-277VAC, 50/60Hz

Photometric Data

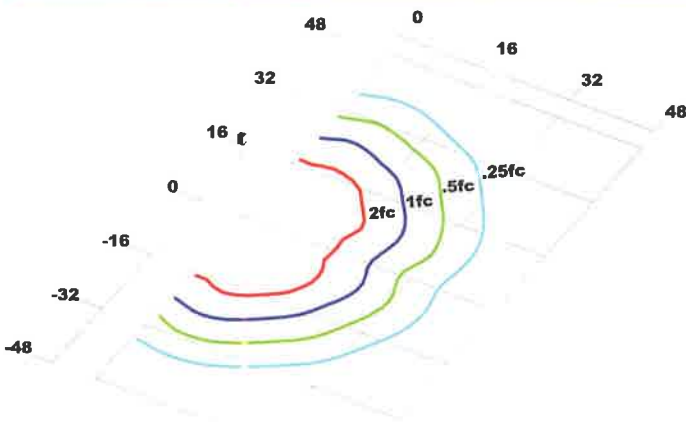

Effective Projected Area (EPA)

EPA (Sq. Ft.)	Weight (Lbs.)
0.48	14 Lbs

ECPF70QF1X84U5KC
Type V
Grid in MH
MH=16 Feet

Photometric Performance

LED Board Watts	Drive Current (mA)	Input Watts	Optics	5000 CCT 80 CRI				4000 CCT 80 CRI					
				Lumens	LPW	B	U	G	Lumens	LPW	B	U	G
ThermaLED 84w	525	86	Type V Clear	8,398	97	3	2	1	8,192	95	3	2	1
			Type V Opal	7,180	83	2	2	1	7,004	81	2	2	1

Projected Lumen Maintenance

Data shown for 5000 CCT			Compare to MH			
TM-21-11	Input Watts	Initial	25,000 Hrs	50,000 Hrs	100,000 Hrs	Calculated L70@ 25°C
L70 Lumen Maintenance @ 25°C / 77°F	86	1.00	0.98	0.97	0.94	473,000
TM-21-11	Input Watts	Initial	25,000 Hrs	50,000 Hrs	100,000 Hrs	Calculated L70@ 50°C
L70 Lumen Maintenance @ 50°C / 122°F	86	1.00	0.97	0.95	0.90	290,000
TM-21-11	Input Watts	Initial	25,000 Hrs	50,000 Hrs	100,000 Hrs	Calculated L80@ 40°C
L80 Lumen Maintenance @ 40°C / 104°F	86	1.00	0.98	0.95	0.91	220,000

NOTES:
1. Projected per IESNA TM-21-11. Data references the extrapolated performance projections for the 626mA base model in a 25°C ambient, based on 10,000 hours of LED testing per IESNA LM-80-08.
2. Compare to MH box indicates suggested Light Loss Factor (LLF) to be used when comparing to Metal Halide (MH) systems.

ECTV2C3 **COB** Technology

Small LED Traverse Wall Accent and Flood Light



1 2802 COMMODITY PL
TAMPA, FL 33626
PHONE: 844-636-2036
SALES@ECO-REVOLUTION.COM
WWW.ECO-REVOLUTION.COM
A QSSI COMPANY SINCE 1985

Order Information Example:

ECTV2C32X20U41KZKN5P

ECTV2C3		41K		KN		
Model	Wattage	Driver	CCT	Color	Mounting	Options
ECTV2C3=Small LED Traverse Wall Accent and Flood Light	2X10=20w 2X20=40w	U=120-277V V=12V* *20w Model Only.	41K=4100K	Z=Bronze C=Custom (Consult Factory)	KN=½" NPS Knuckle (Field Installed)	SF=Single Fuse* DF=Double Fuse* SP=Surge Protection* *Not Available on 12V Model.



Shown with "KN" Knuckle Installed.



The Eco-Revolution ECTV2C3 luminaire is available in two wattages designed to replace HID lighting systems up to 175w MH or HPS. Typical applications include general area, parking, flood, security, and accent lighting for retail centers, industrial parks, schools and universities, public transit and airports, office buildings and medical facilities. Mounting heights of 8 to 15 feet can be used based on light level and uniformity requirements.

Specifications and Features:

Housing:	Die-Cast Gasketed Aluminum Housing, Includes Cast-In Box Template and Built in Level. White Reflector. Nickel-Plated Stainless Steel Hardware.
Listing & Ratings:	CSA: Listed for Wet Locations, ANSI/UL 1598, 8750 IP66 Sealed LED Compartment.
Finish:	Textured Architectural Bronze Powdercoat Finish Over a Chromate Conversion Coating. Custom Colors Available Upon Request.
Lens:	Tempered Clear Flat Glass Lens
Mounting Options:	Mount Directly Over Recessed Electrical Box or Use ½" Surface Conduit or Adjustable Knuckle with ½" NPS Threads, (Included, Field Installed).
COB LED:	Cool Copper COB
Wattage:	20w COB: 20w, System: 21w; (100w HID Equivalent) Note: 12V Model is 20w only. 40w COB: 40w, System: 43w; (175w HID Equivalent)
Driver:	Electronic Driver, 120-277V, 50/60Hz; Less Than 20% THD and PF>0.90. Standard Internal Surge Protection is 2kV for 20w, 6kV for 40w. 0-10V Dimming Standard for a Dimming Range of 100% to 10%; Dimming Source Current is 150 Microamps. 12V: Electronic Driver, 12-17VAC Input, 50/60Hz, Non-Dimmable (20w Model Only)
Controls:	Fixtures Ordered with Factory-Installed Photocell or Motion Sensor Controls are Internally Wired for Switching and/or 1-10V Dimming Within the Housing. Remote Direct Wired Interface of 1-10V Dimming is Not Implied and May Not Be Available, Please Consult Factory. Fixtures are Tested with Eco-Revolution Controls and May Not Function Properly With Controls Supplied By Others. Fixtures are NOT Designed for Use with Line Voltage Dimmers.
Warranty:	5-Year Warranty for -40°C to +50°C Environment.

See Page 3 for Projected Lumen Maintenance Table.

Certification & Listings:



DesignLights Consortium™
Qualified Luminaires:
ECTV2C32X10U41K***
ECTV2C32X20U41K***

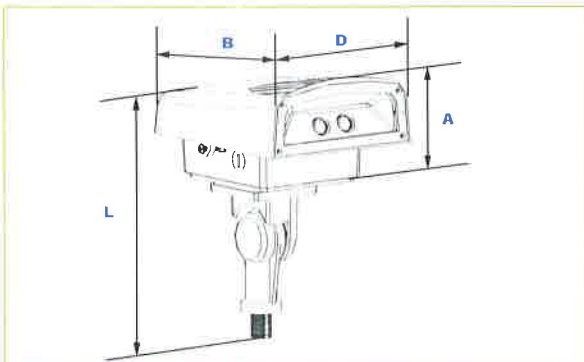

Dimensions

Width (D)	6" (168mm)
Length (B)	7" (200mm)
Height (A)	4½" (114mm)
Length with Mount (L)	10" (270mm)

Project Information:

Project Name:

Complete Catalog #:

Comments:

Fixture Type:

Date:

5 LOCATIONS
Tampa, FL
Vancouver, WA
Cerritos, CA
Walden, NY
Memphis, TN

25

Specifications subject to change without notice. Rev. 081318

ECTV2C3 COB Technology

Small LED Traverse Wall Accent and Flood Light



12802 COMMODITY PL
TAMPA, FL 33626
PHONE: 844-636-2036
SALES@ECO-REVOLUTION.COM
WWW.ECO-REVOLUTION.COM

Accessories & Replacement Parts:



Mounting Accessories (Order Separately, Field Installed)		Accessories (Order Separately, Field Installed)		Replacement Parts (Order Separately, Field Installed)	
ECFLPTFZ	Die-Cast Post Top Fitter for 2 1/4" to 3 1/2" Poles, Bronze Powdercoat Finish, Three (3) 1/2" Coin Plugs.	ECP18110*	110-130V, 120VAC Pencil Photocell	ECFLSTZ	Die-Cast Adjustable Knuckle with 1/2" NPS Threads, Bronze Powdercoat Finish.
ECFLSTK	Heavy Duty Ground Stake, Built-In Wiring Compartment with 1/2" NPS Threaded Fitting, Black Plastic. For Line-Voltage Applications.	ECP18112*	208-277V, 240VAC Pencil Photocell		
ECNA04	Plastic Ground Stake with 1/2" NPT Threads, 11" H x 3" Diameter. For Low-Voltage Applications.	ECNT150BK	150w, 120V Black Powdercoat Steel Landscape Transformer, 12V, with Timer and Photocell		
		ECNT300SS	300w, 120V Stainless Steel Landscape Transformer, 12V, with Timer and Photocell		
		ECNT300SSM	300w, 120V Stainless Steel Landscape Transformer, Multi-Tap 12/14/17V, with Timer and Photocell		

*Shown Mounted

Photometric Data

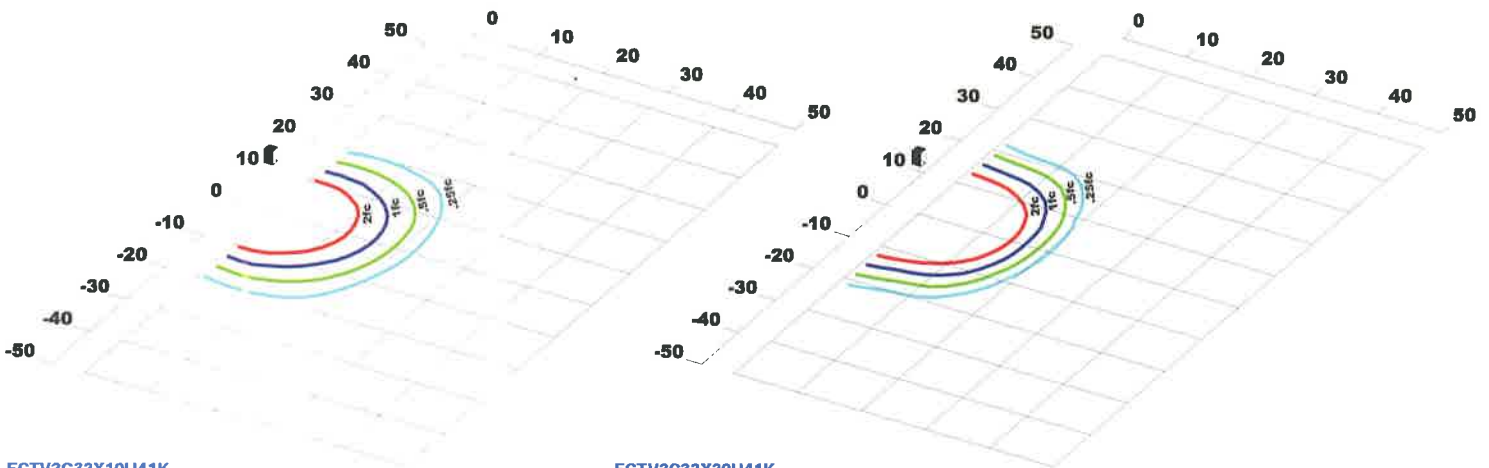

ECTV2C32X10U41K
Type III
Grid in MH
MH=10 Feet

ECTV2C32X20U41K
Type II
Grid in MH
MH=10 Feet

Photometric Performance

LED Board Watts	Drive Current (mA)	Input Watts	Optics	4100K CCT 80 CRI				
				Lumens	LPW	B	U	G
COB LED 21w	525	21	Type II	2,300	110	1	1	0
COB LED 43w		43	Type II	4,025	94	2	1	1

ECTV2C3 COB Technology

Small LED Traverse Wall Accent and Flood Light



12802 COMMODITY PL
TAMPA, FL 33626
PHONE: 844-636-2036
SALES@ECO-REVOLUTION.COM
WWW.ECO-REVOLUTION.COM

Photometric Data

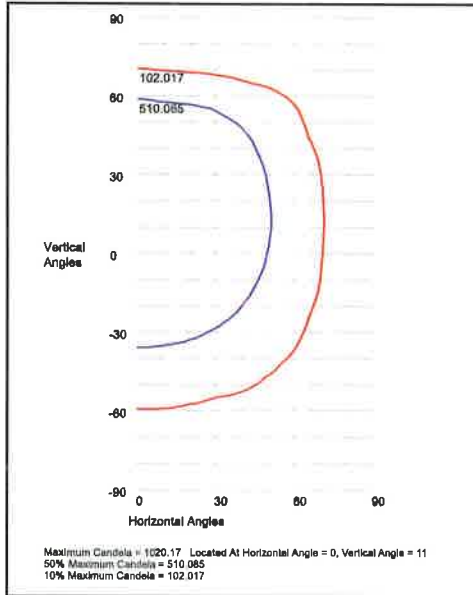

ECTV2C32X10U41K
110°H x 100°V Beam, NEMA 7H x 6V

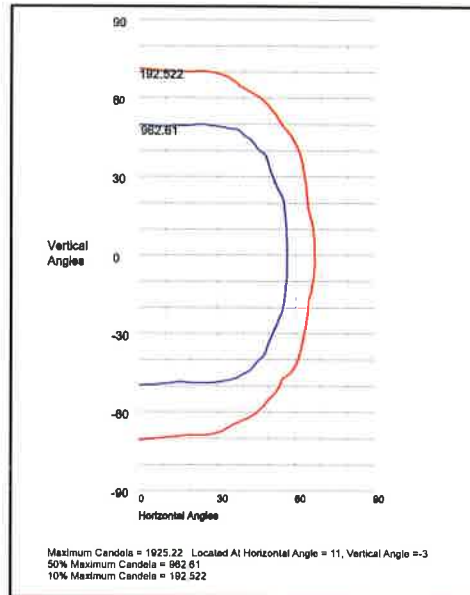

ECTV2C32X20U41K
100°H x 90°V Beam, NEMA 7H x 6V

Photometric Performance

LED Board Watts	Drive Current (mA)	Input Watts	Beam	4100K CCT 80 CRI	
				Lumens	LPW
COB LED 21w	525	21	110°H x 100°V, NEMA 7H x 6V	2,304	110
COB LED 43w		43	100°H x 90°V, NEMA 7H x 6V	4,034	94

Projected Lumen Maintenance

Data shown for 4100 CCT		Compare to MH				
TM-21-1	Input Watts	Initial	25,000 Hrs	50,000 Hrs	100,000 Hrs	Calculated L70@ 25°C
L70 Lumen Maintenance @ 25°C / 77°F	21	1.00	0.91	0.82	0.64	84,000
L70 Lumen Maintenance @ 25°C / 77°F	43	1.00	0.90	0.80	0.61	76,000
TM-21-1	Input Watts	Initial	25,000 Hrs	50,000 Hrs	100,000 Hrs	Calculated L70@ 50°C
L70 Lumen Maintenance @ 50°C / 122°F	21	1.00	0.89	0.78	0.55	67,000
L70 Lumen Maintenance @ 50°C / 122°F	43	1.00	0.86	0.72	0.44	54,000
TM-21-1	Input Watts	Initial	25,000 Hrs	50,000 Hrs	100,000 Hrs	Calculated L80@ 40°C
L80 Lumen Maintenance @ 40°C / 104°F	21	1.00	0.89	0.78	0.57	46,000
L80 Lumen Maintenance @ 40°C / 104°F	43	1.00	0.88	0.76	0.52	42,000

- NOTES:**
1. Projected per IESNA TM-21-11. Data references the extrapolated performance projections for the 525mA base model in a 25°C ambient, based on 10,000 hours of LED testing per IESNA LM-80-08.
2. Compare to MH box indicates suggested Light Loss Factor (LLF) to be used when comparing to Metal Halide (MH) systems.

ECTV3C3 COB Technology

Large LED Traverse Wall and Flood Light



12802 COMMODITY PL
TAMPA, FL 33626
PHONE: 844-636-2036
SALES@ECO-REVOLUTION.COM
WWW.ECO-REVOLUTION.COM
A QESI COMPANY SINCE 1985

Order Information Example:

ECTV3C34X20U41KZKNP

ECTV3C3		U	41K			
Model	Wattage	Driver	CCT	Color	Mounting	Options
ECTV3C3- Large LED Traverse Wall and Flood Light	4X15=60w 4X20=80w	U=120-277V	41K=4100K	Z=Bronze C=Custom (Consult Factory)	KN=½" NPS Knuckle SF=Slipfitter BR=Two-Piece Swivel Bracket *All Mounts Are Field Installed.	SF=Single Fuse DF=Double Fuse SP=Surge Protection



Shown with "SF" Slipfitter Mounting Option.

L70
(25°C) **77,000 Hours**

The Eco-Revolution ECTV3C3 luminaire is available in two wattages designed to replace HID lighting systems up to 400w MH or HPS. Typical applications include general area, parking, flood, security, and accent lighting for retail centers, industrial parks, schools and universities, public transit and airports, office buildings and medical facilities. Mounting can be accomplished using ground attachment accessories and up to heights of 20 feet based on light level and uniformity requirements.

Housing:	Die-Cast Gasketed Aluminum Housing, Includes Cast-In Box Template and Built in Level. White Reflector Nickel-Plated Stainless Steel Hardware.
Listing & Ratings:	CSA: Listed for Wet Locations, ANSI/UL 1598, 8750 IP66 Sealed LED Compartment.
Finish:	Textured Architectural Bronze Powdercoat Finish Over a Chromate Conversion Coating. Custom Colors Available Upon Request.
Lens:	Tempered Clear Flat Glass Lens.
Mounting Options:	Mount Directly Over Recessed Electrical Box, Use ½" Surface Conduit, Heavy-Duty Adjustable Knuckle, Slipfitter, or Two-Piece Swivel Bracket (Field Installed).
COB LED:	Cool Copper COB
Wattage:	60w COB: 60w, System: 56w; (250w HID Equivalent) 80w COB: 80w, System: 80w; (400w HID Equivalent)
Driver:	Electronic Driver, 120-277V, 50/60Hz; Less Than 20% THD and PF>0.90. Standard Internal Surge Protection 6kV. 0-10V Dimming Standard for a Dimming Range of 100% to 10%; Dimming Source Current is 150 Microamps.
Controls:	Fixtures Ordered with Factory-Installed Photocell or Motion Sensor Controls are Internally Wired for Switching and/or 1-10V Dimming Within the Housing. Remote Direct Wired Interface of 1-10V Dimming is Not Implied and May Not Be Available. Please Consult Factory. Fixtures are Tested with Eco-Revolution Controls and May Not Function Properly With Controls Supplied By Others. Fixtures are NOT Designed for Use with Line Voltage Dimmers.
Warranty:	5-Year Warranty for -40°C to +50°C Environment.

Specifications and Features:

Dimensions	
Width (D)	9¾" (248mm)
Length (B)	11¼" (286mm)
Height (A)	6¾" (156mm)
Length with Mount (L)	Bracket (BR): 11¼" (302mm) Knuckle (KN): 11¼" (302mm) Slipfitter (SF): 13¾" (340mm)

See Page 3 for Projected Lumen Maintenance Table.

Certification & Listings:



DesignLights Consortium™
Qualified Luminaires:
ECTV3C34X15U41K***
ECTV3C34X20U41K***



Project Information:	Project Name:	Fixture Type:
	Complete Catalog #:	Date:
	Comments:	

5 LOCATIONS
Tampa, FL
Vancouver, WA
Cerritos, CA
Walden, NY
Memphis, TN

28
Specifications subject to change without notice Rev. 081318

ECTV3C3 COB Technology

Large LED Traverse Wall and Flood Light



12802 COMMODITY PL
TAMPA, FL 33626
PHONE: 844-636-2036
SALES@ECO-REVOLUTION.COM
WWW.ECO-REVOLUTION.COM
A QESI COMPANY SINCE 1985

Accessories & Replacement Parts:



*Shown Mounted

Mounting Accessories (Order Separately, Field Installed)	
ECFLPTFZ	Die-Cast Post Top Fitter for 2 3/4" to 3 1/2" Poles, Bronze Powdercoat Finish, Three (3) 1/2" Coin Plugs.
ECFLSTK	Heavy Duty Ground Stake, Built-In Wiring Compartment with 1/2" NPS Threaded Fitting, Black Plastic.

Accessories (Order Separately, Field Installed)	
ECP18110	110-130V, 120VAC Pencil Photocell
ECP18112	208-277V, 240VAC Pencil Photocell

Replacement Parts (Order Separately, Field Installed)	
ECFLSTZ	Die-Cast Adjustable Knuckle with 1/2" NPS Threads, Bronze Powdercoat Finish
ECFL73SFZX	External Mount Die-Cast Adjustable Silpfitter for 2 3/4" Tenons, Bronze Powdercoat Finish, Includes Hardware.
ECFL73BRZ	Two-Piece Stamped Steel Adjustable Bracket, Bronze Powdercoat Finish, Includes Hardware.

Photometric Data

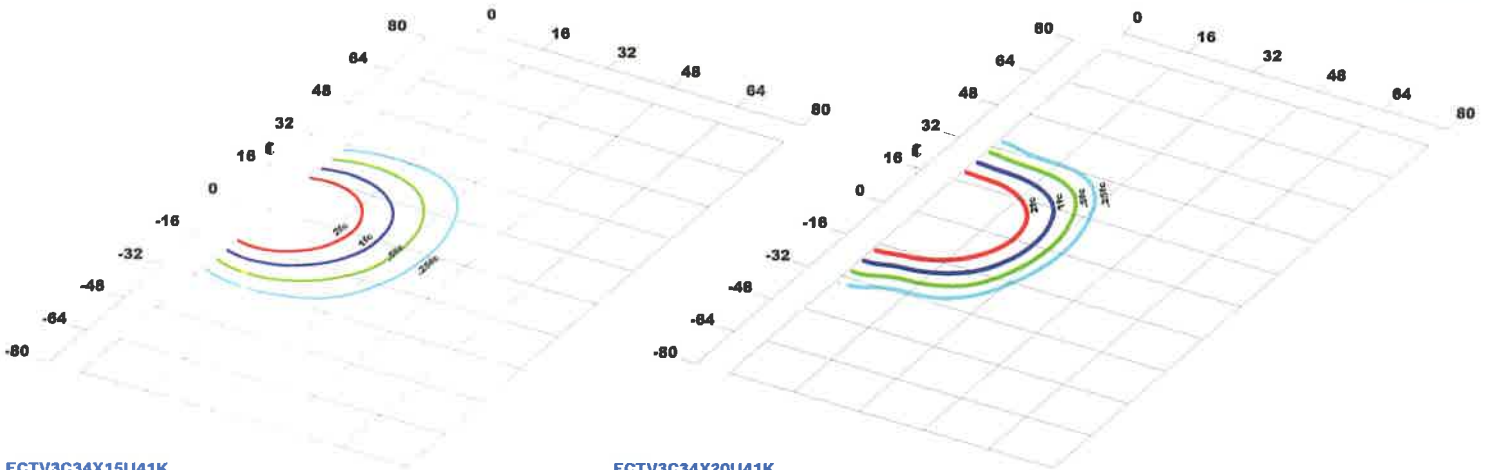

ECTV3C34X15U41K
Type III
Grid in MH
MH=16 Feet

ECTV3C34X20U41K
Type III
Grid in MH
MH=16 Feet

Photometric Performance

LED Board Watts	Drive Current (mA)	Input Watts	Optics	4100K CCT 80 CRI				
				Lumens	LPW	B	U	G
COB LED 60w	525	56	Type III	6,508	116	2	1	1
COB LED 80w		80	Type III	8,212	103	3	1	1

ECTV3C3 COB Technology

Large LED Traverse Wall and Flood Light



12802 COMMODITY PL
TAMPA, FL 33626
PHONE: 844-636-2036
SALES@ECO-REVOLUTION.COM
WWW.ECO-REVOLUTION.COM
A Q591 COMPANY SINCE 1985

Accessories & Replacement Parts:



*Shown Mounted

Mounting Accessories (Order Separately, Field Installed)

ECFLPTFZ	Die-Cast Post Top Filter for 2 3/4" to 3 1/2" Poles, Bronze Powdercoat Finish, Three (3) 1/4" Coin Plugs.
ECFLSTK	Heavy Duty Ground Stake, Bull-In Wiring Compartment with 1/2" NPS Threaded Fitting, Black Plastic.

Accessories (Order Separately, Field Installed)

ECP18110	110-130V, 120VAC Pencil Photocell
ECP18112	208-277V, 240VAC Pencil Photocell

Replacement Parts (Order Separately, Field Installed)

ECFLSTZ	Die-Cast Adjustable Knuckle with 1/2" NPS Threads, Bronze Powdercoat Finish.
ECFL73SFZX	External Mount Die-Cast Adjustable Slipfitter for 2 3/4" Tenons, Bronze Powdercoat Finish, Includes Hardware.
ECFL73BRZ	Two-Piece Stamped Steel Adjustable Bracket, Bronze Powdercoat Finish, Includes Hardware.

Photometric Data

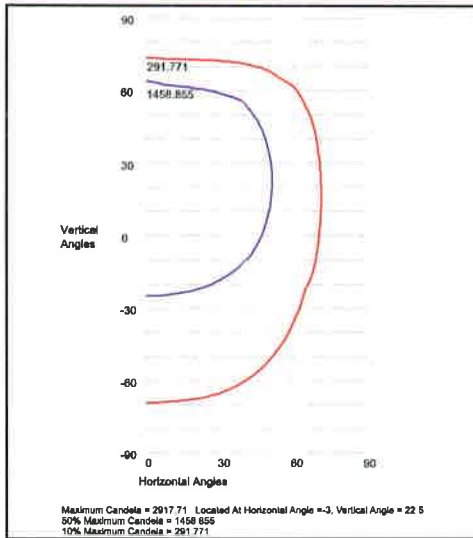

ECTV3C34X15U41K
105°H x 90°V Beam, NEMA 7H x 7V

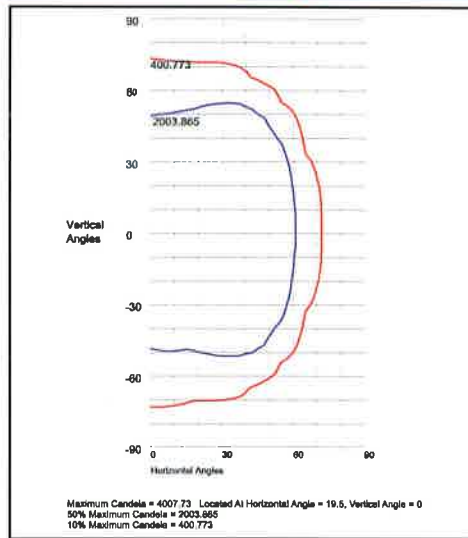

ECTV3C34X20U41K
100°H x 80°V Beam, NEMA 7H x 7V

Photometric Performance

LED Board Watts	Drive Current (mA)	Input Watts	Beam	4100K CCT 80 CRI	
				Lumens	LPW
COB LED 60w	525	56	105°H x 90°V, NEMA 7H x 7V	6,509	116
COB LED 80w		80	100°H x 80°V, NEMA 7H x 7V	8,221	103

Projected Lumen Maintenance

Data shown for 4100 CCT		Compare to MH				
TM-21-11	Input Watts	Initial	25,000 Hrs	50,000 Hrs	100,000 Hrs	Calculated L70@ 25°C
L70 Lumen Maintenance @ 25°C / 77°F	56	1.00	0.91	0.83	0.65	86,000
L70 Lumen Maintenance @ 25°C / 77°F	80	1.00	0.90	0.81	0.61	77,000
TM-21-11	Input Watts	Initial	25,000 Hrs	50,000 Hrs	100,000 Hrs	Calculated L70@ 50°C
L70 Lumen Maintenance @ 50°C / 122°F	56	1.00	0.89	0.78	0.56	68,000
L70 Lumen Maintenance @ 50°C / 122°F	80	1.00	0.87	0.73	0.46	56,000
TM-21-11	Input Watts	Initial	25,000 Hrs	50,000 Hrs	100,000 Hrs	Calculated L80@ 40°C
L80 Lumen Maintenance @ 40°C / 104°F	56	1.00	0.89	0.79	0.57	47,000
L80 Lumen Maintenance @ 40°C / 104°F	80	1.00	0.88	0.77	0.53	43,000

NOTES:
1. Projected per IESNA TM-21-11. Data references the extrapolated performance projections for the 525mA base model in a 25°C ambient, based on 10,000 hours of LED testing per IESNA LM-80-08.
2. Compare to MH box indicates suggested Light Loss Factor (LLF) to be used when comparing to Metal Halide (MH) systems.

Eseta™ LED Wall Sconce ES1

Luminaire Data

Weight 9.9 lbs [4.5 kg]
14.6 lbs [6.5kg] with EM, MS options

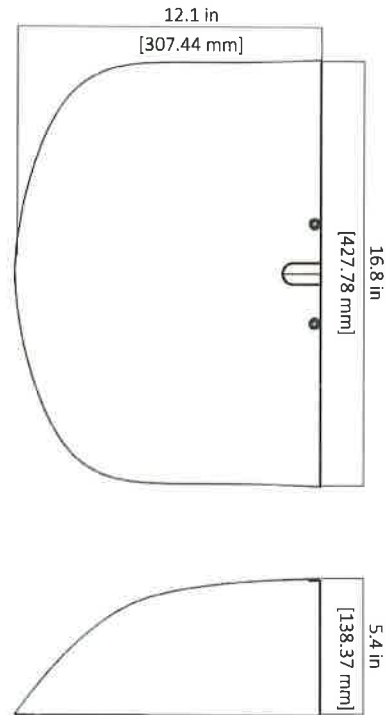

Ordering Information

Sample Catalog No. ES1 24H MV NW W BK 700 EM

Product	No. & Type of LEDs	Voltage	Color Temperature ¹	Distribution	Finish ²	Drive Current ³	Options
ES1	24H 48H	MV	120-277V	WW 3000K	W Wide	350 350mA	PC ⁶ Photo Control
		HV	347-480V	NW 4000K	FT Forward Throw	530 530mA	MSL2 ⁴ Motion Sensor, L2 Lens
				CW 5000K		700 700mA	MSL3 ⁴ Motion Sensor, L3 Lens
							EM ⁵ Emergency Battery System
							FSIR100 Motion Sensor Configuration Tool

Notes:

- 1 Consult factory for other color temperatures.
- 2 Consult factory for non-standard finish options.
- 3 Factory set drive current, non-field adjustable. 700mA is not available for 48H version. Refer to performance data on page 2. Consult factory for other drive current options.
- 4 Motion Sensor available with MV only. Motion Sensor default setting dims luminaire to 50% when no motion is detected for 5 minutes. Field adjustable settings available using FSIR100 option.
- 5 Emergency Battery System available with MV only. 3-year limited warranty on Emergency Battery System.
- 6 Available with MV. Consult factory for HV option, single voltage only, either 347V or 480V.

Eseta™ LED Wall Sconce

ES1

Luminaire Specifications

Housing

Die cast aluminum housing with back mounting plate and outdoor rated cable. Back mounting plate includes novel hanging features to allow one-person installation. Knockouts on the top and bottom of the housing allow conduit entry. Electrical components are accessed behind gasketed optical cover.

Light Emitting Diodes

Hi-flux/Hi-power white LEDs are tested in accordance with IES LM-80 testing procedures. Warm White (3000K), Neutral White (4000K) and Cool White (5000K) with minimum 70 CRI are standard. LEDs are 100% mercury and lead free.

Optical Systems

The OMNILENS™ system creates a low brightness source to reduce glare with precise Wide or Forward Throw distributions. Lens cover is UV stabilized, vandal-resistant polycarbonate. Luminaire produces 0% total lumens above 90° (BUG Rating, U=0).

Electrical

Power supply features a minimum power factor of .90 and <20% Total Harmonic Distortion (THD). EMC meets or exceeds FCC CFR Part 15. Transient voltage complies with ANSI C62.41 Cat. A. Integral surge protector is tested per ANSI/IEEE C62.45 procedures based on ANSI/IEEE C62.41.2 definitions for standard and optional waveforms for Location Category C High.

Finish

Housing receives a fade and abrasion resistant epoxy polyester powder coat. Finish tested to withstand 5000 hours in salt spray exposure per ASTM B117. Finish tested 5000 hours in UV exposure per ASTM G154 and meets ASTM D523 gloss retention.

Listings/Ratings/Labels

Luminaires are UL listed for use in wet locations and emergency lighting in the United States and Canada. Ambient operating temperature is -40°C to 40°C with no accessories installed. Entire fixture maintains an IP66 and IK10 rating. DesignLights Consortium™ 3000K, 4000K and 5000K qualified product. Assembled in the United States.

Photometry

Luminaires are photometrically tested by certified independent testing laboratories in accordance with IES LM-79 testing procedures.

Lumen Maintenance

Models	TM-21 Lumen Maintenance (hours) at 25°C	
	At 50,000	At 100,000
ES1-24H	99%	97%
ES1-48H	97%	93%

Warranty

10-year limited warranty is standard on luminaire and components. 5-year limited warranty on motion sensor and photo control. 3-year limited warranty on Emergency Battery System.

Performance Data

All data nominal, consult factory for IES files or LM-79 reports.

CCT	Two Distributions		Wide Distribution			Forward Throw Distribution		
	No. of LEDs & Type	Drive Current (mA)	System Wattage (W)	Delivered Lumens (Lm)	Efficacy (Lm/W)	System Wattage (W)	Delivered Lumens (Lm)	Efficacy (Lm/W)
3000K	24H	350	30	3205	108	28	3146	112
		530	45	4690	103	43	4604	108
		700	56	5641	101	53	5537	104
	48H	530	83	8826	106	81	8751	108
4000K	24H	350	29	3301	115	30	3471	117
		530	44	4541	104	43	4548	105
		700	59	5771	99	59	5738	98
	48H	530	82	8707	106	83	8466	102
5000K	24H	350	29	3730	130	30	3922	132
		530	44	5131	118	43	5139	119
		700	58	6521	112	56	6260	112
	48H	530	82	9839	120	84	9585	115

Eseta™ LED Wall Sconce ES1

Motion Sensor (Optional) Data

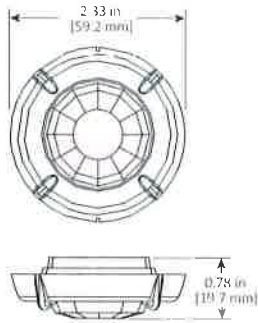

L2 Lens Coverage Top View

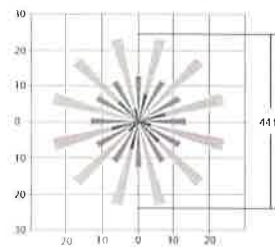

L3 Lens Coverage Top View

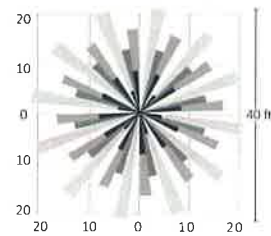

L2 Lens Coverage Side View

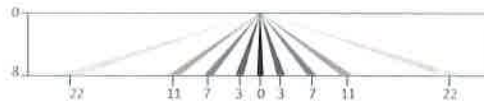

L3 Lens Coverage Side View

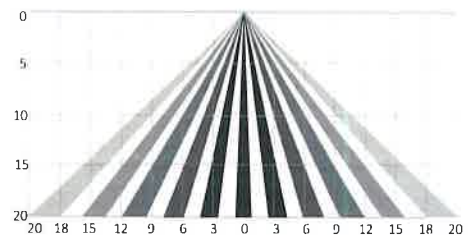

Motion Sensor (Optional) Specifications

Description

Digital passive infrared luminaire integrated outdoor occupancy sensor provides high/low/off control based on motion. Initial setup and subsequent sensor adjustments are made using a handheld configuration tool.

Operation

Standard factory setting will dim the luminaire to 50% until motion is sensed and then it will power to 100%. When motion is not detected for five minutes, the luminaire will dim back to 50%. Ramp up and fade down times are adjustable, but initially set to NONE.

The percent dimming and time durations may be field adjusted as required using FSIR100 option. FSIR user guide available at: www.wattstopper.com.

Optical System

Multi-cell, multi-tier Fresnel lens with a 360 degree view detects unobstructed motion. L2 lens is designed for a mounting height up to 8 feet and detects motion up to 3 times mounting height. L3 lens is designed for a mounting height up to 20 feet and detects motion within one mounting height.

Finish

Sensor exterior ring and lens are white polycarbonate, UV and impact resistant.

Listings/Ratings

Sensor is TUV, UL and cUL listed, IP66 rated and CE compliant.

Warranty

5-year limited warranty on luminaires and components with a motion sensor.

Emergency Battery System (Optional) Specifications

Description

Emergency battery system option provides a nominal 1900 lumens for a minimum of 90 minutes and can be specified with motion sensor option. Test switch and charging indicator light are visible and accessible on the optical cover.

Temperature Rating

Ambient operating temperature is -20C to +60C.

Listings/Ratings/Labels

Emergency LED driver and batteries are UL recognized and CSA certified. Emergency illumination time exceeds the National Electrical Code (NEC), Life Safety Code (NFPA-LSC), National Building Code of Canada (NBC), National Fire Code of Canada (NFC) and UL 90-minute requirements.

Warranty

3-year limited warranty on Emergency Battery System.

A23 25W 277V E26

TITANIUM LED SERIES



25W REPLACES



200W Inc.

80% Energy Savings



Optional Lamp Extender

PRO

- Ⓞ Direct line voltage 120-277V - Not compatible with ballasts
- Ⓞ Omnidirectional: 290° beam angle
- Ⓞ Exceptional efficacy 132 LPW in Cool White
- Ⓞ Frosted diffuser maintains low glare
- Ⓞ Optional lamp extender available for use in larger fixtures
- Ⓞ Suitable for use in totally enclosed fixtures



LM 79

LM 80

TM 21



A23 PRODUCT FEATURES

Suitable for Enclosed Fixtures



This A23 lamp replaces a 200W Inc. and is suitable for use in enclosed fixtures. Its high lumen output and exceptional efficacy make it an ideal choice for bollard, post top, low bay and other outdoor applications. An optional lamp extender is also available for use in larger fixtures.

Omnidirectional Lighting

This A23 emits 290° of uniform light and meets ENERGY STAR requirements. Its compact form factor and omnidirectional output provides a fuller distribution than other LED lamps.



A23 25W 277V E26 TITANIUM LED SERIES



APPLICATIONS

Bollard Lighting



Post Top Lighting



Low Bay Lighting



SPECIFICATIONS

Product Model	97972 25HID/830/277V/E26	97973 25HID/840/277V/E26	97974 25HID/850/277V/E26
Type	A23	A23	A23
Base	E26	E26	E26
Power (W)	25	25	25
Voltage - Frequency	120-277V 50/60Hz	120 277V 50/60Hz	120-277V 50/60Hz
Color Temp. (ANSI)	Warm White 3000K	Cool White 4000K	Daylight 5000K
CRI (Ra) (typ.)	82	82	82
Typical lumens (lm)	3200	3300	3400
Efficacy (LPW)	128	132	136
Beam Angle	290°	290°	290°
Dimmable	No	No	No
Power Factor	0.9	0.9	0.9
Rated Lifetime - L70 (hrs.)	50,000	50,000	50,000
Temperature Rating	-4°F/-20°C - 95°F/35°C	-4°F/-20°C - 95°F/35°C	-4°F/-20°C - 95°F/35°C
Dia. x MOL	3.23"x6.34" (82x161mm)	3.23"x6.34" (82x161mm)	3.23"x6.34" (82x161mm)
Weight (lb. / g)	1.04lb. / 470g	1.04lb. / 470g	1.04lb. / 470g

* Suitable for use in totally enclosed fixtures.

** Suitable for damp locations. Not for use where directly exposed to weather or water.



S8728

6W/H/LED/CFL/840/2P/BP
 6W LED PL 2-PIN; 4000K; 525 Lumens; GX23 base; 50000
 Average rated hours; 120' Beam spread; 120-277V



Features

- Replaces 13 watt CFLs
- Ballast bypass
- Instant on to full brightness / no flickering
- Universal operating position
- Up to 70% energy saving

Suitable for use in totally enclosed, recessed luminaires.
 Enclosed fixture rating based on 8 hours per day of use.

S8728

Item Number	UPC	Watts	Operating Frequency	Fluorescent Equivalent	Lamp Shape	Base	Lamp Code		
S8728	045923087288	6	50/60Hz	13 watt CFL	PL	GX23	6W/H/LED/CFL/840/2P/BP		
Dimmable/Non-Dimmable	Finish	MOL In Inches	MOD In Inches	Initial Lumens	Average Rated Hours	Kelvin Temp	Color		
Non-Dimmable	Frost	5-13/16"	1-1/4"	525	50000	4000	Cool White		
CRI	Beam Spread Deg	Pack	Package Type	CEC Status	RoHS Compliant	UL or ETL Listed	UL Classification		
83	120	50/10	Box	Lawful for sale in California	Yes	Yes	cULus Classified - Damp Location Rated		
				Warranty		5 Year Limited			



National Toll-Free:
800.43.SATCO
(800.437.2826)
www.satco.com

Distribution Centers:
New York, Florida, Texas,
Washington, California,
Puerto Rico

Corporate Offices:
110 Heartland Blvd.,
Brentwood, NY 11717
800.437.2826 631.243.2022
Fax 631.243.2027



©2012, Satco Products, Inc. Not responsible for typographical errors. 06/12 S1051



S29838

9.8A19/OMNI/220/LED/40K
 9.8 watt; A19 LED; 4000K; Medium base; 220° beam spread;
 120 volts

Features

- Solid State LED lighting
- A shaped replacement lamp
- Long life
- Dimmable
- Approved for enclosed fixtures



S29838

Item Number	UPC	Voltage	Watts	Incandescent Equivalent	Power Factor	Lamp Shape	Base
S29838	045923298387	120	9.8	60W	0.98	A19	Medium
ANSI Base	Lamp Code	Dimmable/Non-Dimmable	Suggested Dimmers	Finish	MOL In Inches	MOD In Inches	Initial Lumens
E26	9.8A19/OMNI/220/LED/40K	Dimmable	Compatible dimmers for S29838	Frosted	4-3/16"	2-3/8"	800
Average Rated Hours	Kelvin Temp	Color	CRI	Beam Spread Deg	Operating Temperature	Pack	Package Type
25000	4000	Cool White	80	220	-25C (-13F) to a maximum of +45C (+113F)	24	Box
ENERGY STAR	CEC Status	RoHS Compliant	Fixture Type	UL or ETL Listed	UL Classification	Warranty	
ENERGY STAR	Non-Compliant	Yes	Enclosed Rated	Yes	cULus - Damp Location Rated	5 Year Limited - 10 hour use per day	



National Toll-Free:
800.43.SATCO
(800.437.2826)
www.satco.com

Distribution Centers:
New York, Florida, Texas,
Washington, California,
Puerto Rico

Corporate Offices:
110 Heartland Blvd.,
Brentwood, NY 11717
800.437.2826 631.243.2022
Fax 631.243.2027



©2012, Satco Products, Inc. Not responsible for typographical errors. 06/12 S1051



S29817

15A19/LED/4000K/1600L/120V/D
 15 watt; A19 LED; Frosted; 4000K; Medium base; 220° beam
 spread; 120 volts

Features

- Solid State LED lighting
- A shaped replacement lamp
- Long life
- Dimmable
- UL approved for totally enclosed fixtures



S29817

Item Number	UPC	Voltage	Watts	Incandescent Equivalent	Power Factor	Lamp Shape	Base
S29817	045923298172	120	15	100W	0.96	A19	Medium

ANSI Base	Lamp Code	Dimmable/Non-Dimmable	Suggested Dimmers	Finish	MOL In Inches	MOD In Inches	Initial Lumens
E26	15A19/LED/4000K/1600L/120V/D	Dimmable	Compatible dimmers for S29817	Frosted	4-5/8"	2-3/8"	1600

Average Rated Hours	Kelvin Temp	Color	CRI	Beam Spread Deg	Operating Temperature	Pack	Package Type
25000	4000	Cool White	80	220	-25C (-13F) to a maximum of +45C (+113F)	24/6	Box

ENERGY STAR	CEC Status	RoHS Compliant	UL or ETL Listed	UL Classification	Warranty
ENERGY STAR	Non-Compliant	Yes	Yes	cULus - Damp Location Rated	5 Year Limited - 10 hour use per day



National Toll-Free:
800.43.SATCO
(800.437.2826)
www.satco.com

Distribution Centers:
New York, Florida, Texas,
Washington, California,
Puerto Rico

Corporate Offices:
110 Heartland Blvd.,
Brentwood, NY 11717
800.437.2826 631.243.2022
Fax 631.243.2027



©2012, Satco Products, Inc. Not responsible for typographical errors. 06/12 S1051

LRx4T8 4' Tube & Driver Kit



MECHANICAL

- Retrofits 4ft fluorescent luminaires to LED
- Replaces existing fluorescent lamps and ballasts
- Uses existing lamp holders
- No redesign or revised layout needed

OPTICAL

- 240° Beam distribution for even illumination
- Three CCT options with CRI of 82

KIT INCLUDES

- LED T8 Modules
- LED EVERLINE Driver - Pre-Tuned if applicable
- Wiring, connectors, installation instructions

ELECTRICAL

- Available as 120-277VAC or 347VAC
- Equipped with 0-10V dimmable LED driver to 1%
- LED System efficacies exceed 120 LPW

CERTIFICATIONS

- UL Classified UL 1598C (US & Canada)
- FCC Title 47 CFR, Part 15, Class A
- RoHS Compliant, contains no lead or mercury
- DesignLights Consortium® qualified on select models. Consult www.designlights.org/QPL for details

WARRANTY

- Six (6) year limited warranty

ORDERING GUIDE

EXAMPLE: LR34T8-66L840-10DU

Series	Lamp & Length	Nominal Lumens	CRI (nom.)	Color Temp.	Dimming	Voltage
LR = LED Retrofit	14T8 = 1L 4ft T8	22L = 2,200	8 = 82 (nom.)	35 = 3500K	10D = 0-10V Dimming	U = 120-277VAC 3 = 347VAC
	24T8 = 2L 4ft T8	44L = 4,400		40 = 4000K		
	34T8 = 3L 4ft T8	66L = 6,600		50 = 5000K		
	44T8 = 4L 4ft T8	88L = 8,800				

ORDERING NOTES

† Orders are shipped in standard quantities of 10 drivers and the corresponding number of tubes.

DesignLights Consortium® QPL Listed Products

	Model Number (2-Tube)	Model Number (3-Tube)	Model Number (4-Tube)
120-277V	LR24T8-44L835-10DU	LR34T8-66L835-10DU	LR44T8-88L835-10DU
	LR24T8-44L840-10DU	LR34T8-66L840-10DU	LR44T8-88L840-10DU
	LR24T8-44L850-10DU	LR34T8-66L850-10DU	LR44T8-88L850-10DU
347V	LR24T8-44L835-10D3	LR34T8-66L835-10D3	LR44T8-88L835-10D3
	LR24T8-44L840-10D3	LR34T8-66L840-10D3	LR44T8-88L840-10D3
	LR24T8-44L850-10D3	LR34T8-66L850-10D3	LR44T8-88L850-10D3



PERFORMANCE DATA

	Lumen Package	Input Power (watts)	Input Current			System Output		Reference Luminaire	
			@ 120V	@ 277V	@ 347V	Delivered Lm (nom.)	LPW	Delivered Lm (nom.)	LPW
LR14T8	22L	19	0.16	0.07	0.06	2200	115		N/A
LR24T8	44L	36	0.30	0.13	0.10	4400	122	3328	95
LR34T8	66L	52	0.44	0.19	0.15	6600	127	5015	96
LR44T8	88L	70	0.59	0.26	0.20	8800	126	6616	95

- Performance data provided at 3500K
- Reference Luminaire testing conducted by NVLAP accredited lab in accordance with IESNA LM-79
- Consult factory for photometry.
- Application and performance information is subject to change without notification.

OPERATING DATA

L70 Lumen Maintenance:	>60,000 hrs at 40°C
Min. Starting Temp:	0°F
Sound Rating:	Class A
Power Factor:	> .98
THD:	<20%

LED Driver

Lm Package	LED Driver -UNV	LED Driver -347
LR14T8-22L	D700C30UNVTWCP50K	D700C30347TWCP50K
LR24T8-44L	D10CC55UNVTZCP67C	D10CC55347TZCP67C
LR34T8-66L	D10CC55UNVTZ-C10C	D10CC55347TZ-C10C
LR44T8-88L	D21CC80UNVTWDP67C	D21CC80347TWDP66C

*Projected per IESNA TM-21. Data extrapolated based on 10,000 hours of LED testing per IESNA LM-80

* Where "xx" = 35 (3500K), 40 (4000K), or 50 (5000K) • Where "yy" = UNV (120-277VAC) or 347 (347VAC)

Applications

- All LED Tubes must be connected for proper operation.
- Not for use with plastic cut domes.
- Suitable for 2"x4" with minimum 5" depth, tray, or other fixtures, and may be listed for elevated pendants of up to 48" max in Type Non-IC or up to 25" max in Type IC
- Suitable for 4" or 8" drop light applications, and vapor light (see installation instructions for dimensions and max. wattage)

LED Tube

CCT	LED T8 Tube
3500K	LRT8M22L/B35A
4000K	LRT8M22L/B40A
5000K	LRT8M22L/B50A

DIMENSIONS: in (mm)

Normal Length: 48"

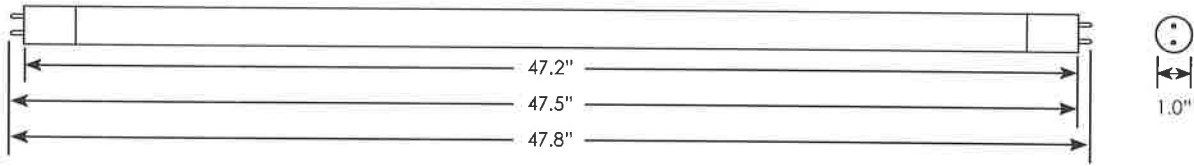

LED Driver Case Dimensions

Case	Length	Width	Height	Mounting Length	Lead Exit
C	14.25"	1.18"	1.00"	13.75"	Side
D	16.88"	1.25"	1.00"	16.28"	Side

POLAR DISTRIBUTION

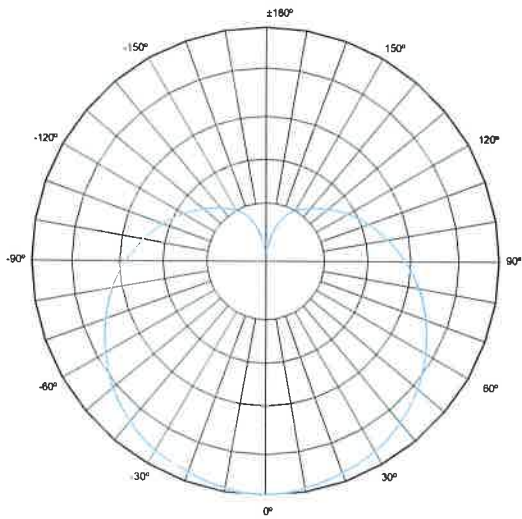

CONNECTION DIAGRAMS

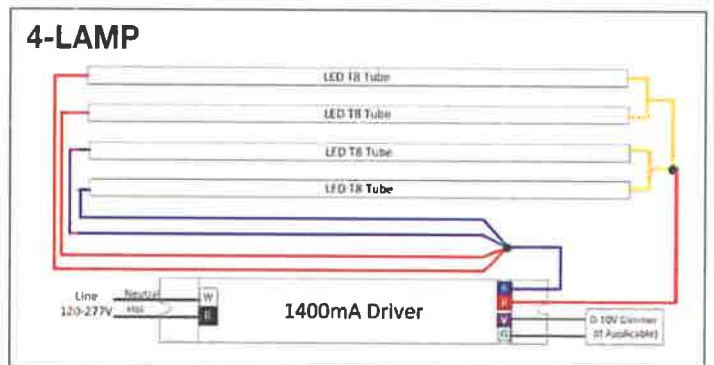
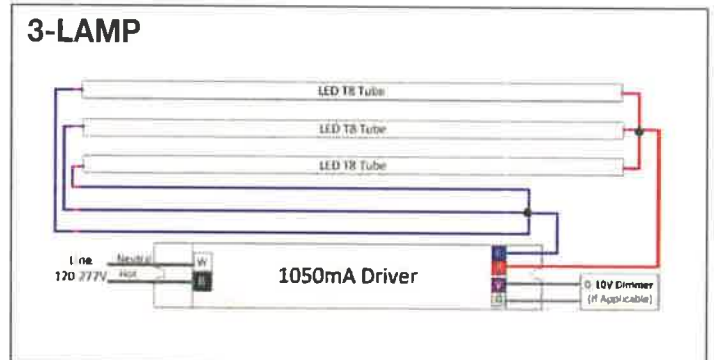
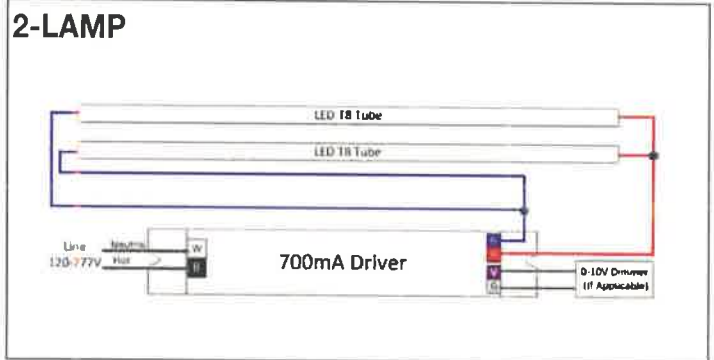

Wiring Diagrams show existing wire colors from an instant start T8 system

PRK LED Professional Retrofit Kit



MECHANICAL

- Retrofits 1'x4', 2'x2' and 2'x4' fluorescent recessed fixtures to LED
- Pan-style kit upgrades outdated optics
- Heavy gauge steel housing and aluminum LED tray
- Corrosion and scratch resistant white enamel finish
- Fast and easy to install

ELECTRICAL

- EVERLINE® light engine includes LED driver & hi-efficacy LED modules
- Available as 120-277VAC or 347VAC
- Standard equipped with 0-10V dimmable LED driver
- LED system efficacies up to 139LPW

OPTICAL

- Low loss frosted acrylic center-basket style diffuser
- Multiple lumen outputs, four CCT options, 80+ CRI

KIT INCLUDES

- Endcaps
- LED panel
- Diffuser
- Side panels
- Mounting hardware (quarter turn screws and disconnects)

CERTIFICATIONS

- UL Classified 1598C (US & Canada)
- FCC Title 47 CFR, Part 15, Class A
- ROHS compliant, contains no lead or mercury
- Select models are DesignLights Consortium™ qualified. Consult www.designlights.org/CPL for details.

WARRANTY

- Five year limited warranty

ORDERING GUIDE

EXAMPLE: PRK22-36W840-U¹

Ordering Information									
Series	Format	Watts	W	CRI	Color Temp.	Voltage	Options		
PRK = Professional Retrofit Kit	14 = 1ft x 4ft	18	W	8 = 80 (minimum)	30 = 3000K 35 = 3500K 40 = 4000K 50 = 5000K	U = 120-277 VAC 347 = 347 VAC	EM ² = Backup Battery Pack		
		24							
		28							
		36							
		50							
	22 = 2ft x 2ft	18							
		25							
		32							
		36							
		50							
	24 = 2ft x 4ft	25							
		28							
		33							
		36							
		46							
		52							
		60							
		70							

ORDERING NOTES:

- 1 Append catalog with 001 for single kit package or B3 for 3 kit bulk package (PRK22 and PRK24 only).
- 2 EM option only available for 120-277 VAC kits

PERFORMANCE DATA

Format	Watts		Delivered Lumens	LPW	Input Current (A)			PF	ThD
	Nominal	Measured			120V	277V	347V		
14	18	17.8	2356	132	0.15	0.06	0.05	> 0.90	< 20%
	24	24.2	3094	128	0.20	0.09	0.07		
	28	28.0	3870	138	0.23	0.10	0.08		
	36	36.0	4742	132	0.30	0.13	0.10		
	50	49.3	6326	128	0.41	0.18	0.14		
22	18	18.1	2339	129	0.15	0.07	0.05		
	25	24.9	3040	122	0.21	0.09	0.07		
	32	32.0	3959	124	0.27	0.12	0.09		
	36	36.0	4644	129	0.30	0.13	0.10		
	50	50.2	6020	120	0.42	0.18	0.14		
24	25	25.8	3265	127	0.22	0.09	0.07		
	28	28.0	3901	139	0.23	0.10	0.08		
	33	33.0	4463	135	0.28	0.12	0.10		
	36	36.0	4781	133	0.30	0.13	0.10		
	46	45.7	6098	133	0.38	0.16	0.13		
	52	52.0	7216	139	0.43	0.19	0.15		
	60	60.0	8036	134	0.50	0.22	0.17		
	70	68.3	9204	135	0.57	0.25	0.20		

LUMEN MAINTENANCE	
Reported per TM-21	L70 > 72,000 hrs
Calculated L70	L70 > 95,000 hrs

PERFORMANCE NOTES:

- Data provided for 4000K at 25C; multiply lumens and LPW by 0.95 for 3000K, 0.97 for 3500K, or 1.03 for 5000K
- Specifications subject to change without notice

DESIGNLIGHTS CONSORTIUM® QPL LISTED PRODUCTS

Model Number	Model Number	Model Number	Model Number	Model Number	Model Number	Model Number
PRK14-18W830-U	PRK14-28W830-U	PRK22-18W830-U	PRK22-32W830-U	PRK24-25W830-U	PRK24-36W830-U	PRK24-60W830-U
PRK14-18W835-U	PRK14-28W835-U	PRK22-18W835-U	PRK22-32W835-U	PRK24-25W835-U	PRK24-36W835-U	PRK24-60W835-U
PRK14-18W840-U	PRK14-28W840-U	PRK22-18W840-U	PRK22-32W840-U	PRK24-25W840-U	PRK24-36W840-U	PRK24-60W840-U
PRK14-18W850-U	PRK14-28W850-U	PRK22-18W850-U	PRK22-32W850-U	PRK24-25W850-U	PRK24-36W850-U	PRK24-60W850-U
PRK14-24W830-U	PRK14-50W830-U	PRK22-25W830-U	PRK22-50W830-U	PRK24-28W830-U	PRK24-52W830-U	PRK24-70W830-U
PRK14-24W835-U	PRK14-50W835-U	PRK22-25W835-U	PRK22-50W835-U	PRK24-28W835-U	PRK24-52W835-U	PRK24-70W835-U
PRK14-24W840-U	PRK14-50W840-U	PRK22-25W840-U	PRK22-50W840-U	PRK24-28W840-U	PRK24-52W840-U	PRK24-70W840-U
PRK14-24W850-U	PRK14-50W850-U	PRK22-25W850-U	PRK22-50W850-U	PRK24-28W850-U	PRK24-52W850-U	PRK24-70W850-U



Model Number	Model Number	Model Number	Model Number
PRK14-36W830-U	PRK22-36W830-U	PRK24-33W830-U	PRK24-46W830-U
PRK14-36W835-U	PRK22-36W835-U	PRK24-33W835-U	PRK24-46W835-U
PRK14-36W840-U	PRK22-36W840-U	PRK24-33W840-U	PRK24-46W840-U
PRK14-36W850-U	PRK22-36W850-U	PRK24-33W850-U	PRK24-46W850-U



DIMENSIONS (in)

PRODUCT ENVELOPE (in)				
Format	L	W	H	lb
1x4 ft	47.75	11.81	2.38	13.0
2x2 ft	23.75	23.75	2.38	11.0
2x4 ft	47.75	23.75	2.38	15.0

Nominal Dimensions

PHOTOMETRIC DATA

LUMINANCE (cd/m ²)				ZONAL LUMENS			CANDELA PLOT		SPACING CRITERIA		
Vert Angle	At 0° Horiz	At 45° Horiz	At 90° Horiz	Zone	Lumens	% Fixture	Angles	10°	And Efficacy Values		
PRK14-36W840-U											
45°	6187	6728	7036	0-20	643	13.6%		1761 Cd	Along	1.24	
55°	5497	6392	6769	0-40	2240	47.2%			Across	1.30	
65°	4624	5782	4696	0-60	3928	82.8%			Lumens	4742	
75°	3635	3677	1930	0-90	4742	100.0%			Watts	36	
85°	2526	1663	1122	0-180	4742	100.0%			Lm/W	132	
PRK22-36W840-U											
45°	4288	4729	5117	0-20	606	13.0%		1674 Cd	Along	1.22	
55°	3742	4496	5049	0-40	2093	45.1%			Across	1.30	
65°	3099	4220	4942	0-60	3659	78.8%			Lumens	4644	
75°	2443	4035	4955	0-90	4644	100.0%			Watts	36	
85°	1784	3130	1787	0-180	4644	100.0%			Lm/W	129	
PRK24-46W840-U											
45°	3030	3321	3503	0-20	785	13.6%		2149 Cd	Along	1.24	
55°	2668	3179	3455	0-40	2728	47.2%			Across	1.30	
65°	2217	2998	3372	0-60	4795	82.8%			Lumens	6098	
75°	1720	2900	3331	0-90	6098	100.0%			Watts	45.7	
85°	1217	2127	1038	0-180	6098	100.0%			Lm/W	133	

CONTRACT

This Contract (“Contract”) is made by and between the Gravenstein Union School District (“District”), and SYLVANIA Lighting Solutions (“Contractor”).

District and Contractor hereby agree as follows:

1. Description of Work

The Contractor agrees to furnish all labor, materials, equipment, tools, supervision, appurtenances, and services, including transportation and utilities, required to perform and satisfactorily complete all work required for the following project (“Project”) in full conformance with the Contract Documents: Proposition 39 Lighting Project

2. Contract Documents

The Contract Documents consist of the executed Contract and all Addenda, all approved change orders, the completed Bid Form, the required Bonds and the Insurance forms, the Notice Inviting Bids, the Instructions to Bidders, the Notice of Award, the Notice to Proceed, the General Conditions and any supplemental conditions, the Technical Specifications, the Drawings, the Project budget with costs and an estimate of the projected energy savings of 24,091 kWh/yr and \$3,523/yr as required under Public Resource Code 26206.

3. Compensation

As full compensation for the Contractor's complete and satisfactory performance of the work and activities described in the Contract Documents, the District agrees to pay Contractor, and Contractor agrees to accept the sum of One Hundred Six Thousand, Two Hundred Thirty Five Dollars and Thirty One Cents (\$ 106,235.31), which shall be paid to the Contractor according to the Contract Documents.

4. Prevailing Wages

This Project is subject to prevailing wage requirements and Contractor and its Subcontractors are required to pay all workers employed for the performance of this Contract no less than the applicable prevailing wage rate for each such worker. If this Contract is for a public works project over \$25,000 or for a maintenance project over \$15,000, as defined in Labor Code sections 1770 et seq., Contractor acknowledges that the project is subject to compliance monitoring and enforcement by the California Department of Industrial Relations in accordance with Labor Code sections 1725.5 and 1770 et seq.

5. Time for Completion

The starting date of the Contract shall be the day listed by the District in the Notice to Proceed and the Contractor shall fully complete all the work before the expiration of 90 calendar days from the starting date. Time is of the essence in the performance of this Contract.

6. Liquidated Damages

Liquidated damages for the Contractor's failure to complete the Contract within the time fixed for completion are established in the amount of \$100 per calendar day.

7. Proposition 39 Compliance

Contractor acknowledges that all Work must qualify as an eligible project under Proposition 39 (Public Resource Code 26200 et seq., and California Energy Commission Guidelines); and that the Scope of Work may be amended to reflect changes in funding allocation and District's expenditure plan, upon mutual agreement of the Parties and a written amendment to this Contract related to any change in scope, payment and duration. Prior to commencement of any Work, District shall review and approve the Project. Contractor shall maintain and make available all Project records for inspection by the District or other agencies.

IN WITNESS WHEREOF, the parties agree to the terms of this Contract on the day and year written below.

District

Contractor

Resolution No.

Contractor License No. and Expiration Date

Date:

By: _____
Individual Signature

Title

Date

If Corporation, Place Seal Below.

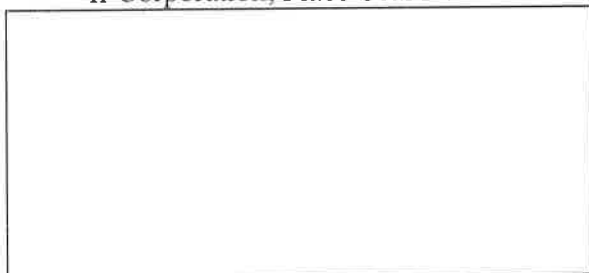

For: _____
Corporation or Partnership

GENERAL CONDITIONS TO CONTRACT

1. DEFINITIONS

Addendum: A written change or revision to the Contract Documents issued to the prospective bidders prior to the time of receiving bids.

Alternate: The sum to be added to or deducted from the base Bid if the change in scope of work as described in Alternates is accepted by the District.

Architect: The person or firm holding a valid license to practice architecture or engineering which has been designated (if any designated) to provide architectural or engineering design services on this Project. If no architect or engineer has in fact been designated, then the matter shall be referred to the District Superintendent.

Bid: The properly completed and signed proposal to perform the construction work for the Project as described in the Contract Documents.

Contract: The legally binding agreement between the District and the Contractor wherein the Contractor agrees to furnish the labor, materials, equipment, and appurtenances required to perform the work described in the Contract Documents and the District agrees to pay the Contractor for such work.

Contract Documents: The Contract Documents are described in the Contract for this Project.

Contractor: The person or entity holding a valid license in the State of California required for performing this Project and who has contracted with the District to perform the construction work described in the Contract Documents.

DSA: The State of California Division of the State Architect.

Final Completion: Final Completion is achieved when the Contractor has fully completed all Contract Document requirements, including, but not limited to, all final punch list items, to the District's satisfaction.

Inspector: The person engaged by the District to conduct the inspections required by the Education Code and Title 24.

Project: The total construction work and activities described in these Contract Documents.

Subcontractor: A person, firm, or corporation, duly licensed by the State of California, who has a contract with the Contractor regarding the Project.

2. ARCHITECT

The Architect is responsible for the overall design of the Project.

3. CONTRACT DOCUMENTS

a. Contents and Precedence

The Contract Documents consist of the executed Contract and all Addenda, all approved change orders, the completed Bid Form, the required Bonds and the Insurance forms, the Notice Inviting Bids, the Instructions to Bidders, the Notice of Award, the Notice to Proceed, the General Conditions, any supplemental Conditions, and the Technical Specifications, the Drawings. The Contract Documents are complementary and anything required by one shall be as binding as if required by all. In case of conflicts within the Contract Documents, the order of precedence of interpretation shall be as listed above, with the executed Contract and any change order thereto having priority, and subsequent Addenda having priority over prior Addenda only to the extent modified by the subsequent Addenda. In case of conflict within the drawings, larger scale drawings shall govern smaller scale drawings, and written dimensions shall govern over scaled dimensions.

b. Ambiguities, Errors, and Inconsistencies

If, in the opinion of the Contractor, the construction details indicated on the drawings or otherwise specified are in conflict with accepted industry standards for quality construction and therefore might interfere with its full guarantee of the work involved, the Contractor shall promptly bring this information to the attention of the Architect for appropriate action before submittal of the bid. Contractor's failure to request clarification or interpretation of an apparent ambiguity, error or inconsistency waives that Contractor's right to thereafter claim any entitlement to additional compensation based upon an ambiguity, inconsistency, or error, which should have been discovered by a reasonably prudent Contractor, subject to the limitations of Public Contract Code §1104. During the Project, should any discrepancy appear or any misunderstanding arise as to the import of anything contained in the Contract Documents, the matter shall be promptly referred to the Architect, who will issue instructions or corrections.

c. Lines and Planes

All lines and planes appearing on Contract drawings to be horizontal or vertical and not explicitly indicated otherwise shall be constructed true and plumb. All lines and planes appearing on Contract drawings to intersect at right angles and not explicitly indicated otherwise shall be constructed at true right angles. Where details are indicated covering specific conditions, such details also apply to all similar conditions not specifically indicated.

d. Standards

The specification standards of the various sections of the Specifications shall be the procedural, performance, and material standards of the applicable association publications identified and shall be the required level of installation, materials, workmanship, and performance for the applicable work. Except where a specific date of issue is mentioned hereinafter, references to specification standards shall mean the edition, including amendments and supplements, in effect on the date of the Notice Inviting Bids. Where no standard is identified and a manufacturer is specified, the manufacturer's specifications are the standards. All standards shall be subordinate to the requirements of the applicable codes and regulations.

Wherever in the Specifications an article, device or piece of equipment is referred to in the singular, such reference shall include as many such items as are shown on drawings or required to complete the installation.

4. INTENT OF DRAWINGS AND SPECIFICATIONS

- a. Drawings and Specifications are to be read as an integrated document.
- b. Figured dimensions shall be followed in preference to scaled dimensions, and the Contractor shall make all additional measurements necessary for the work and shall be responsible for their accuracy. Before ordering any material or doing any work, the Contractor shall verify all measurements at the Project site and shall be responsible for the correctness of same.
- c. It is the intent of the drawings and Specifications to show and describe complete installations. Items shown but not specified, or specified but not shown, shall be included unless specifically omitted.
- d. The Specifications shall be deemed to include and require everything necessary and reasonably incidental to the completion of all work described and indicated on the drawings, whether particularly mentioned or shown, or not.

5. MASTER MANDATORY PROVISIONS

- a. Any material, item, or piece of equipment mentioned, listed or indicated without definition of quality, shall be consistent with the quality of adjacent or related materials, items, or pieces of equipment on the Project and in accordance with best practices.
- b. Any method of installation, finish, or workmanship of an operation called for, without definition of standard of workmanship, shall be followed or performed and finished in accordance with best practices and consistent with adjacent or related installations on the Project.

- c. Any necessary material, item, piece of equipment or operation not called for but reasonably implied as necessary for proper completion of the work shall be furnished, installed or performed and finished; and shall be consistent with adjacent or related materials, items, or pieces of equipment on the Project, and in accordance with best practices.
- d. Names or numbered products are to be used according to the manufacturers' directions or recommendations unless otherwise specified.

6. CONTRACTOR

- a. The Contractor shall perform all the work and activities required by the Contract Documents and furnish all labor, materials, equipment, tools and appurtenances necessary to perform the work and complete it to the District's satisfaction within the time specified. The Contractor shall at all times perform the work of this Contract in a competent and workmanlike manner and, if not specifically stated, accomplish the work according to the best standards of construction practice. The Contractor in no way is relieved of any responsibility by the activities of the architect, engineer, inspector or DSA in the performance of such duties.
- b. The Contractor shall employ a full-time competent superintendent and necessary assistants who shall have complete authority to act for the Contractor on all matters pertaining to the work. The superintendent shall be satisfactory to the District and, if not satisfactory, shall be replaced by the Contractor with one that is acceptable. Also, the superintendent shall not be changed without the written consent of the District unless the superintendent ceases to be employed by the Contractor.
- c. Contractor shall make the layout of lines and elevations and shall be responsible for the accuracy of both the Contractor's and the Subcontractors' work resulting therefrom. All dimensions affecting proper fabrication and installation of all Contract work must be verified by the Contractor prior to fabrication and installation by taking field measurements of the true conditions. The Contractor shall take, and assist Subcontractors in taking, all field dimensions required in performance of the work, and shall verify all dimensions and conditions on the site. If there are any discrepancies between dimensions in drawings and existing conditions which will affect the work, the Contractor shall promptly bring such discrepancies to the attention of the Architect for adjustment before proceeding with the work. Contractor shall be responsible for the proper fitting of all work and for the coordination of all trades, Subcontractors and persons engaged upon this Contract.
- d. Contractor shall do all cutting, fitting, or patching of Contractor's work that may be required to make its several parts come together properly and fit it to receive or be received by work of other contractors as shown, or reasonably implied by, the drawings

and Specifications for the completed work. Any cost incurred by the District due to defective or ill-timed work shall be borne by the Contractor.

7. RESPONSIBILITY OF CONTRACTOR

- a. Contractor shall be held strictly responsible for the proper performance of all work covered by the Contract Documents, including all work performed by Subcontractors. All work performed under this Contract shall comply in every respect to the rules and regulations of all agencies having jurisdiction over the Project or any part thereof.
- b. Contractor shall perform the duties and shall submit Verified Reports as required by Title 24, California Code of Regulations (“CCR”).
- c. With respect to work performed at and near a school site, Contractor shall at all times take all appropriate measures to ensure the security and safety of students and staff, including, but not limited to, ensuring that all of Contractor’s employees, Subcontractors, and suppliers entering school property strictly adhere to all applicable District policies and procedures, e.g., sign-in requirements, visitor badges, and access limitations.

8. SUBCONTRACTORS

- a. Nothing contained in the Contract Documents shall create any contractual relationship between any Subcontractor and the District. The District shall be deemed to be the third party beneficiary of the contract between the Contractor and each Subcontractor. If the Contractor does not specify a Subcontractor for any portion of the work to be performed under this Contract, as required by law, Contractor shall perform that portion of the work with its own forces. The Contractor shall not substitute any other person or firm as a Subcontractor for those listed in the bid submitted by the Contractor, without the written approval of the District and in conformance with the requirements of the Public Contract Code. The District reserves the right of approval of all Subcontractors proposed for use on this Project, and to this end, may require financial, performance, and such additional information as is needed to secure this approval. If a Subcontractor is not approved, the Contractor shall promptly submit another firm of the same trade for approval.

9. PERFORMANCE AND PAYMENT BONDS

- a. If this amount specified in the Notice of Award is \$25,000 or more, as directed in the Notice of Award, the Contractor shall file with the District the following bonds, using the bond forms provided with these Contract Documents:
 - 1) A corporate surety bond, in a sum not less than 100 percent of the amount of the Contract, to guarantee the faithful performance of the Contract.
 - 2) A corporate surety bond, in a sum not less than 100 percent of the amount of the Contract, to guarantee the payment of wages for services engaged and of bills

contracted for materials, supplies, and equipment used in the performance of the Contract.

- b. Corporate sureties on these bonds and on bonds accompanying bids shall be admitted sureties as defined by law, legally authorized to engage in the business of furnishing surety bonds in the State of California. All sureties and bond forms must be satisfactory to the District. Failure to submit the required bonds within the time specified by the Notice of Award, using the forms provided by the District, may result in cancellation of the award of Contract and forfeiture of the Bid Bond.
- c. The amount of the Contract, as used to determine the amounts of the bonds, shall be the total amount fixed in the Contractor's proposal for the performance of the required work.
- d. During the period covered by the Contract, if any of the sureties upon the bonds shall become insolvent or unable, in the opinion of the District, to pay promptly the amount of such bonds to the extent to which surety might be liable, the Contractor, within thirty (30) days after notice given by the District to the Contractor, shall provide supplemental bonds or otherwise substitute another and sufficient surety approved by the District in place of the surety becoming insolvent or unable to pay. If the Contractor fails within such thirty (30) day period to substitute another and sufficient surety, the Contractor shall, if the District so elects, be deemed to be in default in the performance of its obligations hereunder and upon the bid bond, and the District, in addition to any and all other remedies, may terminate the Contract or bring any proper suit or other proceedings against the Contractor and the sureties or any of them, or may deduct from any monies then due or which thereafter may become due to the Contractor under the Contract, the amount for which the surety, insolvent or unable to pay, shall have been liable on the bonds, and the monies so deducted shall be held by the District as collateral security for the performance of the conditions of the bonds.

10. INSURANCE

- a. Contractor shall obtain insurance from a company or companies acceptable to District. All required insurance must be written by an admitted company licensed to do business in the State of California at the time the policy is issued. All required insurance shall be equal to or exceed an A VIII rating as listed in Best's Insurance Guide's latest edition. Required documentation of such insurance shall be furnished to the District at the time Contractor returns the executed Contract. On a case-by-case basis, the District may accept insurance written by a company listed on the State of California Department of Insurance List of Eligible Surplus Lines ("LESLI List") with a rating of A VIII or above as listed in Best's Insurance Guides' latest edition. Required documentation of such insurance shall be furnished to the District within the time stated in the Notice of Award. Contractor shall not commence work nor shall it allow its employees or Subcontractors or anyone to commence work until all insurance required hereunder has been submitted and approved by the District and a notice to proceed has been issued.

b. Contractor shall take out and maintain at all times during the life of this Contract, up to the date of acceptance of the work by the District, the following policies of insurance:

1) General Liability Insurance: Personal injury and replacement value property damage insurance for all activities of the Contractor and its Subcontractors arising out of or in connection with this Contract, written on a comprehensive general liability form including contractor's protected coverage, blanket contractual, completed operations, vehicle coverage and employer's non-ownership liability coverage, in an amount no less than either:

a. \$1,000,000.00 combined single limit personal injury and property damage for each occurrence and \$2,000,000.00 annual aggregate with a \$1,000,000 umbrella/excess; or

b. \$2,000,000.00 annual combined single limit.

2) Builders Risk Insurance:

Contractor is not required to procure and maintain builders' risk insurance (all-risk coverage).

Contractor shall procure and maintain builders' risk insurance (all-risk coverage) on a one hundred percent completed value basis on the insurable portion of the project for the benefit of the District, and the Contractor and subcontractor as their interest may appear.

3) Automobile Liability Insurance: Covering bodily injury and property damage in an amount no less than \$1,000,000 combined single limit for each occurrence. Such insurance shall include coverage for owned, hired, and non-owned vehicles and be included on the umbrella/excess policy.

c. The certificate(s) for the both the General Liability Policy(ies) and the Automobile Liability Policy specified above must state that the insurance is under an occurrence based, and not claims made, policy(ies) and shall be endorsed with the following specific language:

“The Gravenstein Union School District is named as additional insured for all liability arising out of the operations by or on behalf of the named insured, and this policy protects the additional insured, its officers, agents and employees against liability for bodily injuries, deaths or property damage or destruction arising in any respect directly or indirectly in the performance of the Contract.”

- d. The certificate(s) for the both the General Liability Policy and the Automobile Liability Policy, as well the Builders' Risk Policy if required above, shall be endorsed with the following specific language:
- 1) The inclusion of more than one insured shall not operate to impair the rights of one insured against another insured and the coverages afforded shall apply as though separate policies have been issued to each insured.
 - 2) The insurance provided herein is primary and no insurance held or owned by the District shall be called upon to contribute to a loss.
 - 3) Coverage provided by this policy shall not be reduced or canceled without thirty (30) days written notice given to the Owner by certified mail.
 - 4) This policy does not exclude explosion, collapse, underground excavation hazard, or removal of lateral support.
 - 5) The certificates must state that the insurance is under an occurrence based, and not a claims-made, or "modified occurrence," policy (policies).
- e. Within ten (10) days following issuance of the Notice of Award of the Contract, the following documentation of insurance shall be submitted to District for approval prior to issuance of the Notice to Proceed: Certificates of insurance showing the limits of insurance provided, certified copies of all policies, and signed copies of the specified endorsements for each policy. At the time of making application for an extension of time, the Contractor shall submit evidence that the insurance policies will be in effect during the requested additional period of time.
- f. If the Contractor fails to maintain such insurance, the District may take out such insurance to cover any damages of the above mentioned classes for which the District might be held liable on account of the Contractor's failure to pay such damages, and deduct and retain the amount of the premiums from any sums due the Contractor under the Contract.
- g. Workers' Compensation Insurance:
- 1) Within ten (10) calendar days following issuance of the Notice of Award of the Contract, the Contractor shall furnish to the District satisfactory proof that the Contractor and all Subcontractors it intends to employ have procured, for the period covered by the Contract, full Workers' Compensation insurance and employer's liability with limits of at least \$1,000,000 with an insurance carrier satisfactory to the District for all persons whom the Contractor may employ in carrying out the work contemplated under this Contract in accordance with the Workers' Compensation Insurance and Safety Act, approved May 26, 1913, and all acts amendatory or supplemental thereto (the "Act"). Such insurance shall be

maintained in full force and effect during the period covered by the Contract. In the event the Contractor is self-insured, Contractor shall furnish a Certificate of Permission to Self-Insure, signed by the Department of Industrial Relations Administration of Self-Insurance, Sacramento, California.

- 2) If the Contractor fails to maintain such insurance, the District may take out worker's compensation insurance to cover any compensation which the District might be liable to pay under the provisions of the Act, by reason of any employee of the Contractor being injured or killed, and deduct and retain the amount of the premiums for such insurance from any sums due the Contractor under the Contract, or otherwise recover that amount from the Contractor or the Surety.
- 3) If an injury occurs to any employee of the Contractor for which the employee, or the employee's dependents in the event of the employee's death, is entitled to compensation under the provisions of the Act, or for which compensation is claimed from the District, the District may retain from the sums due the Contractor under this Contract an amount sufficient to cover such compensation, as fixed by the Act, until such compensation is paid, or until it is determined that no compensation is due, and if the District is compelled to pay such compensation, it will deduct and retain from such sums the amount so paid, or otherwise recover this sum from the Contractor or its Surety.
- 4) The policies represented by the certificates shall be endorsed with a Waiver of Subrogation and must contain the provision (and the certificates must so state) that the insurance cannot be canceled until thirty (30) days after written notice of intended cancellation has been given to the District by certified mail.

11. CODES AND REGULATIONS

- a. The Contractor shall be knowledgeable regarding and shall comply with applicable portions of Code of Regulations Title 24, the applicable Building Codes, and all other codes, ordinances, regulations or orders of properly constituted authority having jurisdiction over the work of this Project. The Contractor shall examine the Contract Documents for compliance with these codes and regulations and shall promptly notify the Architect of any discrepancies.
- b. All work and materials shall be in full accordance with the latest rules and regulations of the Safety Orders of the Division of Industrial Safety and the applicable State laws and/or regulations. Nothing in the Project plans or Specifications is to be construed to permit work not conforming to the applicable Codes. Buildings and/or all other construction covered by this Contract shall meet all the regulations for access by the physically handicapped as administered by the Division of the State Architect and as may be required by federal or state law.

12. PERMITS AND TAXES

The Contractor shall obtain and pay for all permits, fees and licenses that are required in order to perform the work under this Contract. The District shall pay connection charges and meter costs for new permanent utilities required by these Contract Documents.

The Contractor shall pay for all applicable taxes on materials and equipment.

13. PATENTS AND ROYALTIES

All fees or claims for patents, royalties or licenses on materials, equipment or processes used in the performance of work on this Project shall be included in the amount of the Bid.

14. SAFETY AND FIRE PREVENTION

- a. The Contractor, Subcontractors and all of their agents and employees shall fully comply with all of the provisions and requirements of CAL/OSHA, Title 8, California Code of Regulations and all other safety codes applicable to the Project. The Contractor shall take thorough precautions at all times for the protection of persons and property, and shall be liable for all damages to persons or property, either on or off the site, which occur as a result of Contractor's prosecution of the work. The Contractor shall obtain permits for, install and maintain in safe condition barricades, walkways, fences, railings, and whatever other safeguards that may be necessary to protect persons and property from damage as a result of the construction under this Contract.
- b. Contractor is required to ensure Material Safety Data Sheets ("MSDS") are available in a readily accessible place at the work site for any material requiring a MSDS pursuant to the federal "Hazard Communication" standard or employee "right to know" laws. Contractor is also required to ensure proper labeling on materials brought on the job site such that any person working with the material or within the general area of the material is informed of the hazards of the material and follows proper handling and protection procedures. A copy of the MSDS shall also be promptly submitted directly to the District.
- c. Contractor shall take extraordinary care to prevent fires.

15. HAZARDOUS MATERIALS

Unless otherwise specified, this Contract does not include the removal, handling, or disturbance of any hazardous substances or materials encountered in the new construction or on the Project grounds. If such substances or materials are encountered, work shall cease in that area and the District shall be promptly notified to take appropriate action for removal or otherwise abating the condition in accordance with current regulations applicable to the District.

No asbestos, asbestos-containing products or other hazardous materials shall be used in this construction or in any tools, devices, clothing or equipment used to further this construction.

16. TEMPORARY FACILITIES

The Contractor shall obtain permits for, install and maintain in safe condition all scaffolds, hoisting equipment, barricades, walkways, or other temporary structures that may be required to accomplish the work. Such structures shall be adequate for the intended use and capable of safely accepting all loads that may be imposed upon them. They shall be installed and maintained in accordance with all applicable codes and regulations.

17. SIGNS

No signs may be displayed on or about the District's property (except those which may be required by law) without the District's prior written approval of size, content and location. Any signs required by the District will be designated in the Supplemental General Conditions.

18. TIME

a. The Contractor shall commence the work on the date indicated in the Notice to Proceed. Time is of the essence regarding the Contract work, and the Contractor shall prosecute the work diligently and regularly at such a rate of progress as to ensure completion of this Project within, or sooner than, the time specified.

b. The Contractor and Subcontractors shall provide and maintain enough manpower, materials and equipment to ensure a rate of construction progress that will complete the Project within or sooner than the time specified and according to the schedule of work. If, in the District's opinion, the Contractor and/or Subcontractors are not prosecuting the work at a sufficient rate of progress to meet the Project schedule, the District may direct the Contractor to provide additional manpower, materials or equipment, or to work additional hours, holidays or weekends without additional cost to the District until the work is progressing in a manner satisfactory to the District. Failure to prosecute the work in a timely manner according to the Project schedule is considered a breach of Contract and shall be cause for termination of the Contract.

19. CONSTRUCTION SCHEDULE

a. Within fifteen (15) calendar days after the award of the Contract, the Contractor shall prepare and submit to the Architect and District an as-planned construction schedule showing in detail how the Contractor plans to prosecute the work within the time set for Final Completion. The schedule shall include the work of all trades necessary for construction of the Project, and shall be sufficiently complete and comprehensive to enable progress to be monitored on a day-by-day basis. The information for each activity shall include at a minimum the activity description, duration, start date and completion date.

- b. The Contractor shall take care in the preparation of the schedule to ensure that it represents an accurate and efficient plan for accomplishing the work. If the Project is more than one week behind schedule, it must be promptly revised showing how the Contractor plans to complete the work, but in no case shall it show a completion date later than that required by the Contract, unless a time extension has been granted. The current schedule shall be kept posted in the Contractor's project office on site.

20. DELAYS AND TIME EXTENSIONS

- a. The Contractor may be granted a time extension if the Contractor encounters an unavoidable delay of the work due to causes completely beyond the Contractor's control and which the Contractor could not have avoided by the exercise of reasonable care, prudence, foresight and diligence. The Contractor will not be granted time extensions for weather conditions which are normal for the location of the Project, according to the U. S. Weather Bureau Records.
- b. A request for extension of time and compensation related thereto shall be made in writing to the Architect and District within ten (10) calendar days of the date the delay is encountered, or shall be deemed waived. The request shall include a detailed description of the reasons for the delay and corrective measures by the Contractor.
- c. No damages or compensation of any kind shall be paid to a Contractor because of delays in the progress of work, whether such delays be avoidable or unavoidable, that are not the responsibility of District. District's liability to Contractor for delays for which District is responsible shall be limited to an extension of time unless such delays were unreasonable under the circumstances involved and were not within the contemplation of the parties when the Contract was awarded. The District shall not be liable for any damages which the Contractor could have avoided by any reasonable means including, but not limited to, the more judicious handling of forces or equipment.

21. LIQUIDATED DAMAGES

- a. The parties understand and agree that the goodwill, educational process, and other business of District will be damaged if the Project is not completed within the time limits required. The parties have further agreed that the exact amount of damages for failure to complete the Work within the time specified is, in some cases, extremely difficult, impractical, or impossible to determine. As to those damages that are difficult, impractical, or impossible to determine, Should the Contractor fail to achieve Final Completion of this Contract within the time fixed for Final Completion, together with extensions granted by the District for unavoidable delays, Contractor shall become liable to the District in the amount specified in the Contract per calendar day for each day the Contract remains incomplete beyond the time for Final Completion, as liquidated damages and not as a penalty. Contractor shall not be charged with liquidated damages when the

delay in completion of the work beyond the time for Final Completion is due to acts of the District.

- b. Any money due or to become due the Contractor may be retained to cover liquidated and other delay damages. Should such money not be sufficient to cover those damages, the District shall have the right to recover the balance from the Contractor or Contractor's sureties.
- c. Should the District authorize suspension of the work for any cause, the time work is suspended will be added to the time for completion. Suspension of the work by the District shall not be a waiver of the right to claim liquidated or other delay damages as set forth in this section.

22. DISTRICT'S RIGHT TO STOP WORK; TERMINATION OR SUSPENSION OF THE CONTRACT

a. District's Right to Stop Work:

In addition to or as an alternative to any and all other remedies available to the District, if the Contractor fails to correct work which is not performed in accordance with the Contract Documents, or if the Contractor persistently fails to perform the work in accordance with the Contract Documents, the District may by written order direct the Contractor to stop the work, or any portion thereof, until the cause for such order has been eliminated to the satisfaction of the District. However, the right of the District to stop the work shall not give rise to a duty on the part of the District to exercise this right for the benefit of the Contractor or any other person or entity, and the failure of the District to do so shall not be raised as a defense to the Contractor's failure to perform the work in accordance with the Contract Documents.

b. Termination for Cause:

- 1) If the Contractor refuses or fails to furnish sufficient materials, work force, equipment, and appurtenances to properly prosecute the work in a timely manner, or if Contractor refuses or fails to comply with any provisions of the Contract Documents, or if Contractor should file a bankruptcy petition or make a general assignment for the benefit of Contractor's creditors or if a receiver should be appointed on account of Contractor's insolvency, then the District may give the Contractor and Contractor's Surety written notice of intention to terminate the Contract. Unless within seven (7) calendar days after the serving of such notice upon the Contractor and Contractor's Surety such violation shall cease and arrangements for correction of such conditions shall be made satisfactory to the District, the Contract shall cease and terminate. In the event of such termination,

the District shall immediately serve written notice thereof upon the Contractor and Contractor's Surety.

- 2) In the event of termination for cause, in addition to all remedies available to the District, the Contractor's Surety shall have the right to take over and perform the Contract; provided, however, that if the Surety does not commence performance within five (5) calendar days from the date of the issuance of such notice of termination, the District may take over the work and prosecute the same to completion by letting another Contract, or by any other method that the District deems advisable. The Contractor and Contractor's Surety shall be liable for any excess cost incurred by the District thereby, and in any such event the District may take possession of such materials, equipment, and other property belonging to the Contractor as may be on the site and use same in completing the work.

c. Termination or Suspension for Convenience:

The District reserves the right, in its sole discretion, to terminate or suspend all or part of the Contract for convenience following three (3) days written notice to the Contractor. In the event of termination or suspension for convenience, Contractor shall have no claims against the District, except:

- 1) The actual cost of labor, materials and services provided pursuant to the Contract, and which have not yet been paid for, as documented by timesheets, invoices, receipts and the like; and
- 2) Five percent (5%) of the total cost of the work performed as of the date of notice of termination or suspension or five percent (5%) of the value of the work yet to be completed, whichever is less. The parties agree that this amount shall constitute full and fair compensation for all of Contractor's lost profits and other damages resulting from the termination or suspension for convenience.

23. ASSIGNMENT OF CONTRACT

The Contractor may not assign or delegate all or any portion of this Contract without the written consent of the District and no such consent shall be given which would relieve the Contractor or its Surety of their responsibilities under the Contract. The Contractor may assign, without liability to the District, monies due the Contractor under the Contract to banks, trust companies or other financial institutions provided written notice thereof is promptly delivered to the District. Assignment of monies earned by the Contractor shall be subject to the same retention as other payments made to Contractor, and shall also be subject to setoffs and back charges as provided by this Contract.

24. COORDINATION WITH OTHER CONTRACTS

- a. The District reserves the right to do other work or award other contracts in connection with this Project. By entering into this Contract, Contractor acknowledges that there may be other contractors on or adjacent to the Project site whose work must be coordinated with that of its own. Contractor expressly warrants and agrees that it will cooperate with other contractors and will do nothing to delay, hinder, or interfere with the work of other contractors, or that of the District, its Architect and Construction Manager. Contractor also expressly agrees that in the event its work is hindered, delayed, interfered with, or otherwise affected by a separate contractor, its sole remedy will be a direct action against the separate contractor. To the extent allowed by law, the Contractor expressly waives any remedy against the District, its Architect and Construction Manager on account of delay, hindrance, interference or other such events caused by a separate contractor.
- b. If Contractor is aware of a current or potential conflict between Contractor's work and the work of another contractor on the site, and is unable to informally resolve the conflict directly with the other contractor, Contractor shall promptly provide written notice to the District, with a copy to the Architect and the other contractor, specifying the nature of the conflict, the date upon which the conflict arose, and the steps taken to attempt to resolve the conflict. The District may issue written instructions to address the conflict.
- c. If, through Contractor's negligence, any other contractor or subcontractor shall suffer loss or damage to the work, Contractor shall make a reasonable effort to settle with such other contractor and subcontractor by agreement or arbitration. If such other contractor or subcontractor shall assert any claim against the District or Architect, on account of any damage alleged to have been so sustained, the District or Architect shall notify the Contractor, who shall defend such proceedings at Contractor's own expense and save harmless and indemnify the District and the Architect from any such claim.

25. SUBMITTALS: SHOP DRAWINGS, CUTS AND SAMPLES

- a. Five (5) copies of shop drawings, brochures and cuts and samples in quantities specified by the Architect shall be submitted to the Architect for all items for which they are required by the plans and Specifications. Prior to transmittal, the Contractor shall examine all submittals for accuracy and completeness in order to verify their suitability for the work and compliance with the Contract Documents and shall sign and date each submittal. Submittals shall be made sufficiently before the items are required for the work so as to cause no delay and shall be in accordance with the Project construction schedule.

26. PAYMENTS

- a. Cost Breakdown:

Prior to submitting Contractor's first request for payment, the Contractor shall prepare and submit to the Architect and District a cost breakdown (schedule of values) showing the major work items for each trade or operation required in construction of the Project. The work items shall be sufficiently detailed to enable the Architect to accurately evaluate the

completion percentages requested by the Contractor. The cost for each work item shall include overhead and profit. The total of all work item costs shall equal the amount of the Contract.

b. Progress Payments:

The Contractor will, on or about the last day of each month, make an estimate of the value of the work completed by Contractor in the performance of the Contract. These estimates shall be subject to the review and approval of the Architect. The first such estimate will be of the value of the work completed after the Contractor commenced the performance of the Contract, and every subsequent estimate, except the final estimate, will be of the value of the work completed since the immediately preceding estimate. Such estimates will be based on labor, materials and equipment incorporated into the work, and items of materials and equipment delivered to the Project. The Contractor shall be responsible for the security and protection of such materials and equipment delivered to the Project and not incorporated in the work. Within thirty (30) calendar days after the approval of each estimate for progress payment, the District will pay to the Contractor an amount equal to ninety-five (95) percent of the approved estimate, unless a different retention amount is stated in the notice inviting bids, in which case that sum shall control. Payments may at any time be withheld if in the judgment of the District the work is not proceeding in accordance with the Contract Documents, the Contractor is not complying with the requirements of the Contract, stop notices have been timely filed, the estimate contains an error, or the District has incurred costs or requests reasonable financial assurances regarding defective work by the Contractor.

c. Final Payment:

Within thirty (30) days after all required work is fully completed in accordance with the Contract Documents, the Contractor shall submit a final invoice for the total value of the work completed in accordance with the Contract, which shall be subject to review and approval by the District. As required by law, District shall pay Contractor the unpaid balance of the Contract price of the work, or the whole Contract price of the work if no progress payment has been made, determined in accordance with the terms of the Contract, less such sums as may be lawfully retained under any provision of the Contract, including, but not limited to, amounts retained as liquidated damages, for stop notices, for third-party claims for which the Contractor is required to indemnify the District, for defective work and costs incurred by the District in connection therewith, or for other such claims and damages attributable to the Contractor ("Final Payment"). Prior progress estimates and payments are subject to correction in the Final Payment. Tender of the Final Payment shall constitute denial by the District of any unresolved claim. Contractor's

acceptance of the Final Payment shall operate as a full and final release to the District and its agents from any and all unasserted claims Contractor has, or may have, related to this Contract.

d. Payments Do Not Imply Acceptance of Work:

The granting of any progress payment or payments by the District or the receipt thereof by the Contractor shall not constitute acceptance of the work or of any portion thereof, and shall in no way lessen the liability of the Contractor to replace unsatisfactory work or material, whether or not the unsatisfactory character of such work or material was apparent or detected at the time such payment was made.

e. Release:

The Contractor and each assignee under an assignment in effect at the time of Final Payment shall, if required by the District, execute and deliver at the time of Final Payment and as a condition precedent to Final Payment, a release in form and substance satisfactory to and containing such exemptions as may be found appropriate by the District, discharging the District, its officers, agents and employees of and from liabilities, obligations and claims arising under this Contract.

f. Payment to Subcontractors and Suppliers:

The Contractor shall pay each Subcontractor and supplier promptly on receipt of each progress payment from the District for the materials, labor and equipment delivered to the site or incorporated in the work by each Subcontractor during the period for which the progress payment is made, less any retention as provided above.

gi. Stop Notice Costs:

The District reserves the right to charge the Contractor or Surety, or to withhold from release of retention, all costs incurred by the District, including attorney's fees, for processing and defending stop notice claims.

27. MODIFICATIONS OF CONTRACT

a. Changes In The Work:

1) The District, before the date of acceptance of the work, may, without notice to the Sureties, order changes in the work ("Modifications"), may order extra materials and extra work in connection with the performance of the Contract, and the Contractor shall promptly comply with such orders. All Modifications must be approved by DSA and the State Fire Marshall, if applicable, as required by law.

- 2) If changes ordered in design, workmanship or materials are of such a nature as to increase or decrease the cost of any part of the work, the price fixed in the Contract shall be increased or decreased by such amount as represents the reasonable and proper allowance for the increase or decrease in the cost of the work in accordance with the provisions of this Article, and any other applicable terms of the Contract, including, but not limited to, the Contractor's schedule of values and the price for allowances, if any. Except as provided by law, the total cost of all Modifications shall not exceed ten (10) percent of the original Contract price.
- 3) In the case of a disputed work item, the District may direct the Contractor to perform the disputed work at no additional cost to the District on the grounds that the work is adequately indicated in the Contract Documents, and therefore already included in the Contract price. If the Contractor maintains that the disputed work represents a modification to the Contract, Contractor may submit a claim in accordance with Article 40, Resolution of Construction Claims. Notwithstanding any dispute regarding the requirements of the Contract Documents, Contractor shall promptly and fully comply with the District's directive. Contractor's failure to do so shall be deemed a material breach of this Contract, and in addition to all other remedies, District may, at its sole discretion, hire another contractor and/or use its own forces to complete the disputed work at Contractor's sole expense, and may deduct the cost of such work from the Contract price.

b. Cost Breakdown:

When the Modification is proposed, the Contractor shall furnish a complete breakdown of actual costs of both credits and extras, itemizing materials, labor, taxes, overhead and profit. Subcontract work shall be so indicated. All costs must be fully documented. The following limitations shall apply:

- 1) Limitations Where Contract Price Changes are Involved:
 - (a) Overhead and Profit for the Contractor. The Contractor's overhead and profit on the cost of subcontracts shall be a sum not exceeding ten percent (10%) of such costs. The Contractor's overhead and profit on the costs of work performed by the Contractor shall be a sum not exceeding fifteen percent (15%) of such costs. Overhead and profit shall not be applied to the cost of taxes and insurance by Contractor or Subcontractors or to credits. No processing or similar fees may be charged by the Contractor in connection with the Modification.
 - (b) Bond Premiums. The actual rate of bond premiums as paid on the total cost (including taxes) will be allowed, but with no markup for profit and overhead.

(c) Taxes. State and city sales taxes should be indicated. Federal excise tax shall not be included. (District will issue an exemption on request.)

2) Change Order Certification:

All change orders and requests for proposed change orders shall be deemed to include the following certification by the Contractor:

"The undersigned Contractor approves the foregoing as to the changes in work, if any, and as to the Contract price specified for each item and as to the extension of time allowed, if any, for completion of the Project as stated herein, and agrees to furnish all labor, materials, and service and to perform all work necessary to complete any additional work specified for the consideration stated herein. Submission of claims which have no basis in fact or which Contractor knows are false are made at the sole risk of the Contractor and may be a violation of the False Claims Act, as set forth in Government Code §§12650 *et seq.* It is understood that the changes to the Contract Documents set forth herein shall only be effective upon approval by the Governing Board of the District.

"It is expressly understood that the value of the extra work or changes expressly includes any and all of the Contractor's costs and expenses, both direct and indirect, resulting from additional time required on the Project or resulting from delay to the Project. Any costs, expenses, damages, or time extensions not included herein are deemed waived."

c. Unit Prices, Schedule of Values, or Allowances:

Where Unit Prices, a Schedule of Values, and/or Allowances are required by the Contract Documents, that pricing shall govern in computing any additions to or deductions from the Contract price on account of any added or omitted work. Unit Prices listed in the original bid include all costs and no addition of any description will be allowed.

d. Time and Materials:

If it is impractical, because of the nature of the work, or for any other reason, to fix an increase in price in advance, the Change Order may fix a maximum price which shall not under any circumstances be exceeded, and subject to such limitation, such alteration, modification or extra shall be paid for at the actual necessary cost as determined by the sum of the following items (1) to (5) inclusive:

- 1) Labor, including premium on compensation insurance and charge for Social Security taxes, and other taxes pertaining to labor.
- 2) Material, including sales taxes and other taxes pertaining to materials.

- 3) Plant and equipment rental, to be agreed upon in writing before the work is begun. No charge for the cost of repairs to plant or equipment will be allowed.
- 4) Overhead and profit computed at fifteen percent (15%) of the total of Items (1) to (3) inclusive.
- 5) The proportionate cost of premiums on bonds computed at one and one-half percent (1-1/2%) of the total of items (1) to (4) inclusive.

If the Time and Materials work is done by a Subcontractor, the amount shall be determined as set forth above under items (1) to (5) inclusive. The Contractor's overhead and profit on the costs of subcontracts (exclusive of taxes and insurance) shall not exceed ten percent (10%) of such costs.

The District reserves the right to furnish such materials as it may deem expedient, and no allowance will be made for profit thereon. The above-described methods of determining the payment for work and materials shall not apply to the performance of any work or the furnishing of any material which, in the judgment of the District, may properly be classified under items for which prices are established in the Contract.

e. Oral Modifications:

No oral statements of any person shall in any manner or degree modify or otherwise affect the terms of the Contract.

28. INDEMNITY

Contractor shall defend with counsel acceptable to the District, indemnify and hold harmless to the full extent permitted by law, the District and its Board of Trustees, officers, agents, Architect, construction manager, employees and volunteers from and against any and all liability, loss, damage, claims, expenses, fines, judgments and costs (including, without limitation, attorney's fees and costs and fees of litigation) (collectively, "Liability") of every nature arising out of or in connection with Contractor's performance of the Project or its failure to comply with any of its obligations contained in these Contract Documents, except such Liability caused by the sole negligence or willful misconduct of the District. Such indemnification shall extend to all claims, demands, or liabilities occurring after completion of the project as well as during the progress of the work. Pursuant to Public Contract Code §9201, District shall timely notify Contractor of receipt of any third-party claim relating to this Project.

29. WARRANTY OF TITLE

Contractor warrants that title to all work, materials or equipment included in a request for payment shall pass and transfer to the District whether or not they are installed or incorporated in the Project, free from any claims, liens or encumbrances, when such payment is made to the Contractor. Contractor further warrants that no such work, materials or equipment have been

purchased for work under the Contract subject to an agreement by which an interest therein or an encumbrance thereon is retained by the seller or supplier.

30. GUARANTEE AND WARRANTY

- a. By signing this Contract, Contractor agrees to the following guarantee and warranty:

Guarantee & Warranty

Contractor hereby guarantees and warrants its work on the Project for a period of two (2) years from the date of the filing of the Notice of Completion as follows.

Contractor shall promptly repair or replace to the satisfaction of the District any or all work that appears defective in workmanship, equipment and/or materials for whatever reason, ordinary wear and tear and unusual abuse or neglect excepted, together with any other work which may be damaged or displaced in so doing.

Contractor agrees to promptly correct and remedy any failure by the Contractor to conform its work, activities and services to the requirements of the Contract Documents.

In the event of the Contractor's failure to comply with the above-mentioned obligations within ten (10) calendar days of notice, or sooner if required by an emergency, Contractor hereby authorizes the District to have the defects or deficiencies repaired, remedied, corrected and made good at Contractor's expense, and Contractor shall pay the costs and charges therefore upon demand. The Surety agrees to be responsible for these costs and charges as well.

31. SUBSTITUTIONS

- a. Wherever in the drawings or Specifications a material or product is called for by trade or brand names or manufacturer and model number, alternative items of equal quality and purpose may be proposed for use by the Contractor. The burden of proof of equality is on the Contractor, and Contractor shall furnish all information and supplies necessary for the Architect to make a thorough evaluation of the proposed substitution. The Architect's decision about the equality of the proposed substitution is final, and if the proposed substitution is not approved, the Contractor shall install the item called for. Proposed

substitutions and any changes in adjacent work caused by them shall be made by the Contractor at no additional cost to the District.

- b. In the event Contractor makes substitutions in materials, equipment, or designs, with or without the District's approval, other than those authorized herein, the Contractor shall then assume full responsibility for the effects of such substitutions on the entire Project, including the design, and shall reimburse the District for any charges resulting from such substitutions, including any charges for modifications in the work of other trades, and including any charges for additional design and review, plus reasonable and customary mark-ups.

32. INSPECTION

- a. All materials, equipment and workmanship used in the work of the Project shall be subject to inspection or testing at all times and locations during construction and/or manufacture. Any material or work found to be unsatisfactory or not according to the Contract Documents shall be replaced with the correct material or work and the defective items promptly removed, all at the Contractor's expense, when directed to do so by any of the above-named persons having authority over the work. The cost of review time and analysis by the Architect or other District consultants necessitated by incomplete or defective work by the Contractor shall be charged to the Contractor.
- b. Inspection and testing by the District or its representatives shall not relieve the Contractor from complying with the requirements of the Contract Documents. The Contractor is responsible for its own quality control.

33. CLEANUP

- a. The Contractor shall maintain the premises and area of the work in a neat and clean condition. No burning of rubbish on site shall be allowed. The Contractor shall control dust on the site by sprinkling at whatever intervals are necessary to keep it laid down and shall take measures to prevent dust and debris from being accidentally transported outside the area of the work.

34. INSTRUCTIONS AND MANUALS

Three copies of the maintenance instructions, application/installation instructions and service manuals called for in the Specifications shall be provided by the Contractor.

35. AS-BUILT DRAWINGS

The Contractor and all Subcontractors shall maintain on the work site a separate complete set of contract drawings which will be used solely for the purpose of recording changes made in any portion of the work during the course of construction, regardless of the reason for the change. As changes occur, there will be included or marked on this record set on a daily basis if necessary to

keep them up to date at all times. Progress payments may be delayed or withheld until such time as the record set is brought up to date to the satisfaction of the Architect. The Contractor shall verify that all changes in the work are included in the "AS-BUILT" drawings and deliver the complete set thereof to the Architect for review and approval within thirty (30) calendar days after District's notice of completion. District's acceptance and approval of the "AS-BUILT" drawings are a necessary condition precedent to the release of the final retention.

36. SUBSTITUTION OF SECURITIES

- a. Pursuant to Public Contract Code §22300, Contractor may request in writing that it be allowed at its own expense to substitute securities for moneys withheld by District to ensure performance under this Contract. Only securities listed in Government Code §16430 and bank or savings and loan certificates of deposit, interest-bearing demand deposit accounts, standby letters of credit, or any other security mutually agreed to by Contractor and District shall qualify under this Article. Securities equivalent to the amount withheld shall be deposited with the District or with a state or federally chartered bank in California as the escrow agent. Upon satisfactory completion of the Contract and on written authorization by the District, the securities shall be returned to Contractor. Contractor shall be the beneficial owner of the securities and shall receive any interest thereon. The Contractor may alternatively request District to make payment of retentions earned directly to the escrow agent at the expense of the Contractor.
- b. At the expense of the Contractor, the Contractor may direct the investment of the payments into securities and the Contractor shall receive the interest earned on the investments upon the same terms provided for above for securities deposited by Contractor. Upon satisfactory completion of the Contract, Contractor shall receive from the escrow agent all securities, interest, and payments received by the escrow agent from the District. The Contractor shall pay to each Subcontractor, not later than 20 days of receipt of payment, the respective amount of interest earned, net of costs attributed to retention withheld from each Subcontractor, on the amount of retention.
- c. Any escrow agreement entered into pursuant to this Article shall comply with Public Contract Code §22300 and shall be subject to approval by District's counsel.

37. LABOR STANDARDS

The Contractor shall comply with the Labor Code as it pertains to this project. In accordance with Labor Code §1810, eight (8) hours of labor shall constitute a legal day's work under this Contract. Contractor and any Subcontractor shall pay workers overtime pay as required by Labor Code §1815. The Contractor shall pay each worker, laborer, mechanic or persons performing work under this Contract at a rate not less than the prevailing wage for each craft or classification covering the work actually performed.

Contractor shall comply with Labor Code §§1773.3, 1777.5 and 1777.6, and 3077 *et. seq.* with regard to apprentices, each of which is incorporated by reference into this Contract. .

As required by Labor Code §1773.2, the District has available copies of the general prevailing rate of per diem wages for workers employed on public work as determined by the Director of the Department of Industrial Relations, which shall be available to any interested party on request. Contractor shall post a copy of the document at each job site.

The Contractor and each Subcontractor shall pay each worker performing work under this Contract at a rate not less than the prevailing wage as defined in Labor Code §1771 and 1774 and §16000(a) of Title 8, California Code of Regulations.

The Contractor agrees to comply with the provisions of §§1776 and 1812 of the Labor Code. The Contractor and each Subcontractor shall keep or cause to be kept an accurate record showing the names, addresses, social security numbers, work classifications, straight time and overtime hours worked each day and week of all workers employed by Contractor in connection with the execution of this Contract or any subcontract thereunder and showing the actual per diem wages paid to each of such workers.

38. PROJECT COMPLETION

- a. When all of the work to be performed under this Contract has been fully completed, the Contractor shall notify the Architect and District, in writing, setting a date for inspection. The Contractor and Subcontractor representatives shall attend the inspection. As a result of this inspection, the Architect will prepare a list of items ("punch list") that are incomplete or not installed according to the Contract Documents. Failure to include items on this list does not relieve the Contractor from fulfilling all requirements of the Contract Documents.
- b. The Architect will promptly deliver the punch list to the Contractor and it will include a period of time by which the Contractor shall complete all items listed thereon. On completion of all items on the punch list, verified by a final inspection, and all other Contract requirements, so that Final Completion has been achieved to the District's satisfaction, the District will file a Notice of Completion with the County Recorder. Payment of retention from the Contract, less any sums withheld pursuant to the terms of this Contract or applicable law, shall not be made sooner than thirty-five (35) calendar days after the date of filing of Notice of Completion.
- c. District reserves the right to occupy buildings and/or portions of the site at any time before Completion, and occupancy shall not constitute final acceptance of any part of the Work covered by the Contract Documents, nor shall such occupancy extend the date specified for completion of the Work. Beneficial occupancy of building(s) does not commence any warranty period or entitle Contractor to any additional compensation due to such occupancy, or affect in any way or amount Contractor's obligation to pay liquidated damages for failure to complete the Project on time.

39. TRENCHING OR OTHER EXCAVATIONS

a. Excavations or Trenches Deeper than Four Feet:

If the Project involves digging trenches or other excavations that extend deeper than four feet, the following provisions shall be a part of this Contract:

- 1) The Contractor shall promptly, and before the following conditions are disturbed, provide written notice to the District if the Contractor finds any of the following conditions:
 - (a) Material that the Contractor believes may be a hazardous waste, as defined in §25117 of the Health and Safety Code, which is required to be removed to a Class I, Class II, or Class III disposal site in accordance with the provisions of existing law.
 - (b) Subsurface or latent physical conditions at the site which are different from those indicated or expected.
 - (c) Unknown physical conditions at the site of any unusual nature or which are materially different from those ordinarily encountered and generally recognized as inherent in work which the Contractor generally performs.
 - 2) In the event that the Contractor notifies the District that Contractor has found any of the conditions specified in subparagraphs (a), (b) or (c), above, the District shall promptly investigate the condition(s). If the District finds that the conditions are materially different or that a hazardous waste is present at the site which will affect the Contractor's cost of, or the time required for, performance of the Contract, the District shall issue a change order in accordance with the procedures set forth in this Contract.
 - 3) In the event that a dispute arises between the District and the Contractor regarding any of the matters specified in Paragraph (2), above, the Contractor shall proceed with all work to be performed under the Contract and the Contractor shall not be excused from completing the Project as provided in the Contract. In performing the work pursuant to this Paragraph, the Contractor retains all rights provided by Article 40 which pertains to the resolution of disputes between the contracting parties.
- b. Regional Notification Center: The Contractor, except in an emergency, shall contact the appropriate regional notification center at least two (2) days prior to commencing any excavation if the excavation will be conducted in an area that is known, or reasonably should be known, to contain subsurface installations other

than the underground facilities owned or operated by the District, and obtain an inquiry identification number from that notification center.

c. Existing Utility Lines:

- 1) Pursuant to Government Code §4215, the District assumes the responsibility for removal, relocation, and protection of main or trunk utility lines and facilities located on the construction site at the time of commencement of construction under this Contract with respect to any such utility facilities that are not identified in the plans and Specifications.
- 2) Locations of existing utilities provided by the District shall not be considered exact, but approximate within reasonable margin and shall not relieve Contractor of responsibilities to exercise reasonable care nor costs of repair due to Contractor's failure to do so.
- 3) No provision herein shall be construed to preclude assessment against Contractor for any other delays in completion of the Project. Nothing in this section shall be deemed to require the District to indicate the presence of existing service laterals, appurtenances, or other utility lines, with the exception of main or trunklines, whenever the presence of such utilities on the site of the construction Project can be inferred from the presence of other visible facilities, such as buildings, meter and junction boxes, on or adjacent to the site of the construction.
- 4) If Contractor, while performing work under this Contract, discovers utility facilities not identified by the District in the Project plans and Specifications, Contractor shall immediately notify the District and the utility in writing. The cost of repair for damage to above-mentioned visible facilities without prior written notification to the District shall be borne by the Contractor.

d. Trenches Five Feet and Deeper:

Pursuant to Labor Code §6705, if the Contract price exceeds \$25,000 and involves the excavation of any trench or trenches five (5) feet or more in depth, the Contractor shall, in advance of excavation, promptly submit to the District and/or a registered civil or structural engineer employed by the District or Architect, a detailed plan showing the design of shoring for protection from the hazard of caving ground during the excavation of such trench or trenches.

40. RESOLUTION OF CONSTRUCTION CLAIMS

- a. Public work claims of \$375,000 or less between the Contractor and the District are subject to the provisions of Article 1.5 (commencing with §20104) of Chapter 1 of Part 2 of the Public Contract Code ("Article 1.5 claim"). For purposes of Article 1.5, "public work" has the same meaning as set forth in §§3100 and 3106 of the Civil Code; "claims" means a

separate demand by Contractor for a time extension or payment of money or damages arising from work done by or on behalf of Contractor pursuant to the Contract and payment of which is not otherwise expressly provided for or the claimant is not otherwise entitled to or the amount of the payment which is disputed by the District.

- b. All Article 1.5 claims shall be submitted on or before the date of the Final Payment and shall include all documents necessary to substantiate the claim. District shall respond in writing within 45 days of receipt of claim if the claim is less than or equal to \$50,000 ("50,000 claim") or within 60 days if the claim is over \$50,000 but less than or equal to \$375,000 ("50,000 - 375,000 claim"). In either case, District may request in writing within 30 days of receipt of claim any additional documentation supporting the claim or relating to any defenses to the claim which the District may have against the Contractor. Any additional information shall be requested and provided upon mutual agreement of the District and the Contractor. District's written response to the claim shall be submitted to Contractor within 15 days after receipt of the further documentation for \$50,000 claims or within 30 days after receipt of the further documentation for \$50,000 - \$375,000 claims or within a period of time no greater than that taken by the Contractor in producing the additional information, whichever is greater.
- c. Within 15 days of receipt of the District's response, if Contractor disputes the District's written response, or within 15 days of the District's failure to respond within the time prescribed, the Contractor shall provide written notification to District demanding an informal conference to meet and confer ("conference") to be scheduled by District within 30 days. Following the conference, if any claim or portion remains in dispute, the Contractor may file a claim as provided in Chapter 1 (commencing with §900) and Chapter 2 (commencing with §910) of Part 3 of Division 3.6 of Title 1 of the Government Code. For purposes of those provisions, the period of time within which a claim must be filed is tolled from the time the claimant submits a written claim pursuant to this section until the time that claim is denied as a result of the conference process, including any period of time utilized by the meet and confer process.
- d. Pursuant to Public Contract Code §20104.2(f), this section does not apply to tort claims and does not change the period for filing claims or actions specified by Chapter 1 (commencing with §900) and Chapter 2 (commencing with §910) of Part 3 of Division 3.6 of Title 1 of the Government Code.
- e. If a civil action is filed, within 60 days, but no earlier than 30 days, following the filing of responsive pleadings, the court shall submit the matter to nonbinding mediation unless waived by mutual stipulation of both parties. The mediation process shall provide that both parties select a disinterested third person mediator within 15 days, shall be commenced within 30 days of the submittal, and shall be concluded within 15 days of the commencement of the mediation unless time is extended upon a good cause showing to the court or by stipulation of the parties. If the parties fail to select a mediator within the 15-day period, any party may petition the court to appoint the mediator.

- f. If the matter remains in dispute, the case shall be submitted to judicial arbitration as set forth in Public Contract Code §§20104.4 (b)(1) through (b)(3).
- g. For any claim in excess of \$375,000, the Contractor and the District shall follow the same process as for an Article 1.5 claim. The District will forward a response within 60 days of submittal of any such claim. Judicial arbitration is not required for claims in excess of \$375,000.

Claims shall also be processed consistent with Public Contract Code section 9204, which provides processing timelines and procedures, and requires that undisputed claims be promptly paid in accordance with this code provision.

- h. In addition, for all unresolved claims that the Contractor wishes to pursue, the Contractor shall file a timely claim pursuant to the Government Claims Act and shall otherwise comply with the procedures set forth in that Act prior to commencing any litigation against the District. The accrual date for any such claim is the date the dispute or controversy first arose regarding the issues raised in the claim.
- i. “The date of Final Payment,” as used in this Article 40, means the date the public entity is required to release retention proceeds in accordance with Public Contract Code §7107 regardless of whether any payment is made to the Contractor at that time.
- j. The claims required by this Article are jurisdictional and conditions precedent to the commencement of any further legal proceedings. Strict compliance with all filing deadlines is mandatory.

41. FINGERPRINTING

(Applies to K-12 districts only.)

The District has considered the totality of the circumstances concerning the Project and has determined that the Contractor and Contractor's employees (which includes Subcontractor employees):

_____ are subject to the requirements of Education Code §45125.2 and Paragraph (a) below, is applicable.

 X are not subject to the requirements of Education Code §45125.2, and Paragraph (b) below, is applicable.

- a. Contracts for Construction, Reconstruction, Rehabilitation or Repair of a School Facility Involving More than Limited Contact with Students (§45125.2)

By execution of the Contract, the Contractor acknowledges that Contractor is entering into a contract for the construction, reconstruction, rehabilitation, or repair of a school facility

where the Contractor and/or Contractor's employees will have more than limited contact with students and the services to be provided do not constitute an emergency or exceptional situation. In accordance with Education Code §45125.2 the Contractor shall, at Contractor's own expense, (1) install a physical barrier to limit contact with students by Contractor and/or Contractor's employees, and/or (2) provide for the continuous supervision and monitoring of the Contractor and/or Contractor's employees by an employee of the Contractor who has received fingerprint clearance from the California Department of Justice, and/or (3) provide for the surveillance of the Contractor and Contractor's employees by a District employee.

b. Contracts for Construction, Reconstruction, Rehabilitation or Repair of a School Facility Involving Only Limited Contact With Students (§45125.2)

By execution of the Contract, the Contractor acknowledges that Contractor is entering into a contract for the construction, reconstruction, rehabilitation or repair of a school facility involving only limited contact with students. Accordingly, the parties agree that the following conditions apply to any work performed by the Contractor and Contractor's employees on a school site: (1) Contractor and Contractor's employees shall check in with the school office each day immediately upon arriving at the school site; (2) Contractor and Contractor's employees shall inform school office staff of their proposed activities and location at the school site; (3) Once at such location, Contractor and Contractor's employees shall not change locations without contacting the school office; (4) Contractor and Contractor's employees shall not use student restroom facilities; and (5) If Contractor and/or Contractor's employees find themselves alone with a student, Contractor and Contractor's employees shall immediately contact the school office and request that a member of the school staff be assigned to the work location.

42. DRUG-FREE WORKPLACE CERTIFICATION

Contractor certifies all of the following:

- 1) Contractor is aware of the provisions and requirements of California Government Code §§ 8350 et seq., the Drug Free Workplace Act of 1990.
- 2) Contractor is authorized to certify, and does certify, that a drug free workplace will be provided by doing all of the following:
 - a) Publishing a statement notifying all employees that the unlawful manufacture, distribution, dispensation, possession or use of a controlled substance is prohibited in Contractor's workplace and specifying actions which will be taken against employees for a violation of the prohibition;
 - b) Establishing a drug-free awareness program to inform employees about all of the following:

- (i) The dangers of drug abuse in the workplace;
 - (ii) Contractor's policy of maintaining a drug-free workplace;
 - (iii) The availability of drug counseling, rehabilitation and employee-assistance programs; and
 - (iv) The penalties that may be imposed upon employees for drug abuse violations;
- c) Requiring that each employee engaged in the performance of Work on the Project be given a copy of the statement required by subdivision (a), above, and that as a condition of employment by Contractor in connection with the Work on the Project, the employee agrees to abide by the terms of the statement.
- 3) Contractor understands that if the District determines that Contractor has either: (a) made a false certification herein, or (b) violated this certification by failing to carry out and to implement the requirements of Government Code §§ 8350 et seq., the Contract is subject to termination, suspension of payments, or both. Contractor further understands that, should Contractor violate the terms of the Drug-Free Workplace Act of 1990, Contractor may be subject to debarment in accordance with the provisions of Government Code §§ 8350, et seq.

43. OTHER PROVISIONS

- a. This contract is / is not subject to Disabled Veteran Business Enterprise requirements. If this contract is subject to those requirements, the following apply:
- 1) In accordance with Education Code §17076.11, this District has a participation goal for disabled veteran business enterprises (“DVBE”) of at least 3 percent (3%) per year of the overall dollar amount of funds allocated to the District by the State Allocation Board pursuant to the Leroy F. Greene School Facilities Act of 1998 for construction or modernization and expended each year by the District. Prior to, and as a condition precedent for final payment under any contract for such project, the Contractor shall provide appropriate documentation to the District identifying the amount paid to DVBE in conjunction with the Contract, so that the District can assess its success at meeting this goal.
 - 2) The Contractor agrees that, for all contracts subject to DVBE participation goals, the State and the District have the right to review, obtain and copy all records pertaining to performance of the contract in accordance with DVBE requirements. The Contractor agrees to provide the State or the District with any relevant information requested and shall permit the State or District access to its premises upon reasonable notice for purposes of interviewing employees and inspecting records. The Contractor agrees to maintain such records for a period of three years after final payment under the Contract.

- b. The project is subject to compliance monitoring and enforcement by the California Department of Industrial Relations. In accordance with SB 854, all bidders, contractors and subcontractors working at the site shall be duly registered with the Department of Industrial Relations at time of bid opening and at all relevant times. Proof of registration shall be provided as to all such contractors prior to the commencement of any work.
- c) Contractor shall coordinate with the Architect to ensure that DIR is advised of the award of the construction contract in a timely manner by filing form PWC-100 with DIR within five days of award of the contract.

44. PROVISIONS REQUIRED BY LAW DEEMED INSERTED

Every provision of law and clause required by law to be inserted in this Contract shall be deemed to be inserted, and this Contract shall be read and enforced as though it were included, and if through mistake or otherwise any provision is not inserted or is not correctly inserted, upon application of either party the Contract shall be amended to make the insertion or correction.

45. GENERAL PROVISIONS

a. Assignment and Successors:

Neither party may transfer or assign its rights or obligations under the Contract Documents, in part or in whole, without the other party's prior written consent. The Contract Documents are binding on the successors, and permitted assigns of the parties hereto.

b. Third Party Beneficiaries:

There are no intended third party beneficiaries to the Contract.

c. Choice of Law and Venue

The Contract Documents shall be governed by California law, and venue shall be in the Superior Court of the county in which the project is located, and no other place.

d. Severability

If any provision of the Contract Documents is determined to be illegal, invalid, or unenforceable, in part or in whole, the remaining provisions, or portions of the Contract Documents shall remain in full force and effect.

e. Entire Agreement

The Contract Documents constitute the final, complete, and exclusive statement of the terms of the agreement between the parties regarding the subject matter of the Contract Documents and supersedes all prior written or oral understandings or agreements of the parties.

f. Waiver

No waiver of a breach, failure of any condition, or any right or remedy contained in or granted by the provisions of the Contract Documents shall be effective unless it is in writing and signed by the party waiving the breach, failure, right, or remedy.

--END--

V C.

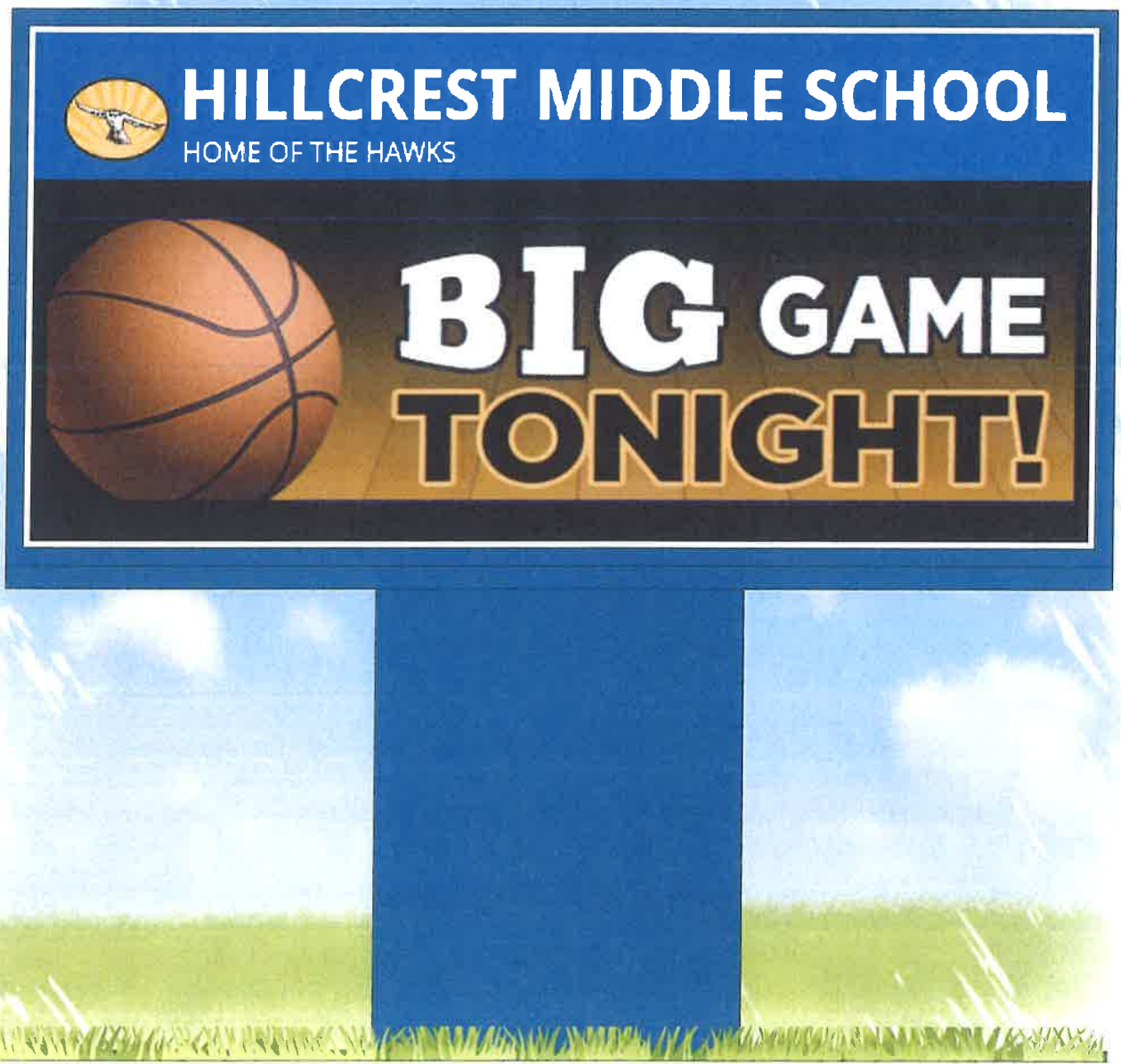

HILLCREST MIDDLE SCHOOL



HOME OF THE HAWKS



**BIG GAME
TONIGHT!**

The provided graphics will be insufficient quality for the manufacturing process. Please see our web site, <http://www.stewartsigns.com/support-artwork.php> or your consultant for a list of acceptable formats.

TekStar 16mm 40x140 4'x8'

Cabinet: 4' x 8'
Mount: Pedestal

Cabinet Color: Bristol Blue
Face Color: Bristol Blue

Logo: hillcrestmsnameandlogosnip



stewart signs
The World's Premier Sign Company

1-800-237-3928 WWW.STEWARTSIGNS.COM

ORIGINAL DESIGN DO NOT DUPLICATE

DUE TO THE PHYSICAL LIMITATIONS OF THE PAPER AND INK BASED PRINTING PROCESS, THIS CUSTOM ARTWORK IS NOT INTENDED TO PROVIDE AN EXACT MATCH TO SWISS INK VINYL. PAINT OR FELT CUT OR ARTIST'S IMITATION OF BRICKWORK, MASONRY AND ANGSTAPING IS NOT INCLUDED IN THE PROPOSAL. ANY MEASUREMENTS SHOWN ARE APPROXIMATIONS. DIMENSIONS OF FINAL PRODUCT MAY VARY. LETTERS AND NUMBERS ARE SIMULATED TO REPLICATE RESOLUTION FROM OPTIMUM VIEWING DISTANCE. A STEWART SIGN IS DESIGNED TO BE ILLUMINATED AT ALL TIMES AS IT INCREASES THE LIFE OF THE SIGN'S LIGHTING COMPONENTS. SKETCHES ARE BASED OFF OF THIS PREMISE.

APPROVED AS SHOWN.

X _____ DATE _____ 1 _____

APPROVED WITH LISTED CHANGES.

X _____ DATE _____ 2 _____

X _____ DATE _____ 3 _____

TEKSTAR, DAYSTAR EXP & DEFENDER
FULL COLOR
Capabilities for 16MM 40 Pixel High Matrix



2 ROWS
12.6"



CAPABLE OF
3 ROWS
OF 8.4" TEXT

THIS SIGN
IS CAPABLE OF
DISPLAYING 1 TO 5
ROWS OF TEXT
4.4" TO 25.2"

CAPABLE OF
DISPLAYING
4 ROWS
OF 6.3" TEXT



HILLCREST MIDDLE SCHOOL
 3842 TWIG AVE
 SEBASTOPOL, CA 95472

Consultant:
 Laurie Pierson, x234
 lpierson@stewartsigns.com
 Direct Fax: (888) 586-3964
 Customer ID: 1398735
 Quote #: 926055 / 1
 Quoted: 12/6/2018

DESCRIPTION

4'x 8' Single Sided 16mm TekStar with 40x 140 Full Color LED Display. Thermoformed Makrolon SL Face, Decorated on Inside Surface with 3M Vinyl Graphics. 12" Deep Extruded Aluminum Hinged Cabinet.

Face / Cabinet Details

Internal TekStar Cabinet with Complete LED Display Assembly, 16mm 40x140 Color

Header Area Decorated with Internal Photo-Real Graphics

Electrical Information

One 20 Amp Circuit, 120 Volts; Max Draw: 10.4 Amps

LED Communication Method: Ethernet Cat5/6 Cable.
 Maximum Cable Length: 333 Feet

SignCommand.com Cloud-Based Software Included FREE for Lifetime of Product. Please visit www.signcommand.com for more information**.

Structural Details

Mount Style: Dual Leg Mount

Cowling (Creates Pedestal Appearance)

Mount Size:

Leg Height: 3 Ft 6 In

Leg Width: 2 Ft 8 In

Overall Sign Height: 7 Ft 6 In

Minimum Wind Load Rating: 120mph, Exposure B

Miscellaneous Items

*** Review Custom Artwork for Text, Graphic and Layout Details ***

I.D. Cabinet: Bristol Blue

Draft: White

Header Background: Bristol Blue

Header Copy: White

Mount: Bristol Blue

<p>Special Instructions:</p> <p>\$13,477.00 Single Sided \$19,984.00 Double Sided</p> <p>*Freight is included in this price</p> <p>* Tax (CA State tax) will be added to your final bill.</p> <p>*These prices do not include installation</p> <p>*Stewart Signs is a CMAS provider</p>	<p>Investment: \$13,477.00</p> <p>Unless otherwise noted in Special Instructions, these prices are valid for 30 days.</p> <p>Freight, storage, other freight services and applicable sales tax will be added to your invoice.</p> <p>Organizations exempt from sales tax must include exempt certificate with order.</p> <p>Shipping Terms: F.O.B. Origin</p> <p>Payment Terms: 50% Down, Balance due 10 days after shipment</p>
---	---

** By purchasing the SignCommand.com product, you are agreeing with the Website Terms of Use (<https://www.signcommand.com/terms>) and Software End User License Agreement (<https://www.signcommand.com/eula>).

Your Consultant: Laurie Pierson
(800) 237-3928, x234

Customer ID: 1398735

Quote Number: 926055 / 1

Date Quoted: 12/6/2018

Customer's Authorized Signature

12/6/2018

Print Name

Date

Laurie Pierson, Regional Manager - School Division
(800) 237-3928, x234
lpierson@stewartsigns.com

Date

Your Consultant: Laurie Pierson (800) 237-3928, x234	Customer ID: 1398735	Quote Number: 926055 / 1	Date Quoted: 12/6/2018
---	----------------------	--------------------------	------------------------

SHIPPING INFORMATION	
SIGN (via Common Carrier)	*** All applicable items will be sent to the CUSTOMER address *** *** unless noted otherwise below ***
HILLCREST MIDDLE SCHOOL 3842 TWIG AVE SEBASTOPOL, CA 95472	
INVOICE (via USPS)	
HILLCREST MIDDLE SCHOOL 3842 TWIG AVE SEBASTOPOL, CA 95472	

ORDERING PROCEDURES

1. Check proposal for accuracy and, if approved, sign and date where indicated.
2. Approve design and colors on the custom artwork. Be sure to check spelling. If approved, sign and date the artwork.
3. Write deposit check according to terms listed on proposal form's header, made payable to EBSCO Sign Group LLC, dba Stewart Signs.
4. Return signed custom artwork, signed proposal form and deposit check to Stewart Signs.

** Unless indicated under special instructions, permits, footers, erection, electrical service, electrical hook-up and planters or other decorative masonry are the responsibilities of the buyer. Stewart Signs furnishes engineered footer drawings when applicable.*

** Any cancellation may be subject to a cancellation charge.*

** A late fee of 1.5% per month will be charged on any overdue balances.*

** In the event of a payment default, customer will be responsible for all of Stewart Signs costs of collection, including but not limited to court costs, filing fees and attorney fees.*

Stewart Signs
America's Premier Sign Company
Limited Product Warranty ("Limited Warranty")

Definition of Warranty Coverage:

- 1) EBSCO Sign Group, LLC, dba Stewart Signs (the "Company") expressly warrants to the original purchaser ("You" or "Buyer" or "Owner" or "Customer") that, for a period of five (5) years from the date of shipment (the "Warranty Period"), the electronic displays and the associated Company products (the "Product") will be reasonably free of material defects in materials and workmanship impacting Product fit, form and/or function. During the Warranty Period, the Company will, at its discretion, repair or replace any defective covered Product. The Owner will be responsible for removing and reinstalling any and all repaired or replacement parts. This Limited Warranty only applies to the Company's Product if installed, used, and maintained in the manner recommended by Company, and this Limited Warranty is conditioned upon compliance with all such instructions. Lifetime telephone support for the Product is provided, as needed.
- 2) In the event the Product is damaged during shipping, it is the responsibility of the Buyer to refuse delivery, causing the Product to be returned to the manufacturer for repair. Title to the Product passes to the Buyer upon the Company's delivery to the freight carrier. The Company assumes no liability for damage caused by careless handling or poor installation, except for work completed by employees of the Company. Loss or damage to the Product when in possession of the freight carrier is the responsibility of the Customer and is not covered by this Limited Warranty.
- 3) Any information or suggestion by the Company with respect to the Product concerning applications, specifications or compliance with zoning, codes and standards is provided solely for your convenience and without any representation as to accuracy or suitability. You must verify and test the suitability of any information with respect to the Product for your specific application.
- 4) Sign Structure and Sign Face: In the event the sign structure or identification/changeable copy portion of the sign malfunctions under normal use and service thereof DURING THE LIFE OF THE SIGN due to material defects in workmanship or materials, the Company will, at its option, repair or replace any defective materials.
- 5) Vandalism to Sign Faces: This Limited Warranty covers polycarbonate faces against breakage due to vandalism DURING THE LIFE OF THE SIGN. Warranty protection does not extend to these surfaces if damaged by gunshots, or when damaged coincident with damage to the sign cabinet in which the faces are installed.
- 6) Failed electronic parts or assemblies, with the exception of lamps, will be repaired or replaced, at the sole discretion of the Company. Owner bears the expense and responsibility of shipping Product to Company's Repair Center. Replacement or repaired parts are warranted to be free from material defects in material or workmanship for ninety (90) days, or for the remainder of the Warranty Period of the Product they are replacing or in which they are installed, whichever is longer.
- 7) The Company will repair failed LED pixels if greater than one half of one percent (0.5%) of the total number of pixels in the sign have failed in one (1) calendar year, provided the sign is installed with the recommended ventilation system for its location. The definition of pixel failure is when all LED's in the pixel will no longer emit light. Pixel repair is performed at the Company Repair Center. It is common knowledge within the sign industry that all LEDs degrade and produce less light as they age. Eventually the LEDs will require replacement even though the LEDs will still emit light. This Limited Warranty does not cover normal LED degradation.
- 8) **Customer Obligations:**
Failure by the Customer to properly maintain the Product, including but not limited to filters and the ventilation/air conditioning systems, will void coverage for affected components. The Customer shall notify the Company immediately of equipment failure and allow the Company full and free access to the Product when required. Waiver of liability or other restriction shall not be imposed as a site access requirement. The Customer is responsible for all costs and management oversight associated with providing the Company access to the Product, providing the necessary machines, communication facilities and other equipment, inclusive of but not limited to lifting equipment. Should on-site repair be required, Customer is required to have a responsible individual on-site to provide access to the Product as well as sign off on a completed work order.
- 9) **Exclusions and Restrictions:**
The Company reserves the right to restrict service, limit replacement parts or invalidate this Limited Warranty to Customers whose account balance is past due. This Limited Warranty specifically excludes any on-site labor required to service the covered Product including diagnosis, removal and installation of parts or products. Any on-site service required by the Customer of Company technicians or a local authorized service provider is billable to the Customer based on an agreed upon written quote.
This Limited Warranty does not apply to software. Software is covered by a separate agreement, which appears in the Company's software license agreement.
Ballasts are covered for a period of three (3) years.
ID cabinet LED illumination and power supply are covered for a period of two (2) years, when purchased as a system.
- 10) This Limited Warranty specifically does not cover the following:
 - a) Third-party communication devices such as wireless devices and modems, which are covered by a separate electronic communication warranty.
 - b) Damage to Product that has been moved from its original installation location or is mounted in a mobile structure.
 - c) Cosmetic damage to the Product (including but not limited to scratches and dents that do not otherwise affect the fit, form or functionality of the Product or materially impair its use).
 - d) Temperature sensor results: temperature sensors will register variable results, given local environmental factors such as direct sunlight, distance from concrete or asphalt, etc.; results are not guaranteed or covered under this Limited Warranty.
 - e) Recovery or transfer of any data or software stored on the Product not originally installed on the Product by the Company.
 - f) Light bulbs or lamps.
- 11) This Limited Warranty specifically does not cover conditions, defects or damage caused by or resulting from the following:
 - a) Defects caused by unreasonable or unintended use of Product, improper or unauthorized handling, accident, omission, neglect, vandalism (unless otherwise noted in this Limited Warranty), misuse, physical abuse, installation, use and/or fabrication, and maintenance of the Product by any party other than the Company.
 - b) Damage not resulting from manufacturing defects that occurs while the Product is in the Owner's control and/or possession.

- c) Extreme physical or electrical stress or interference; environmental conditions beyond the Company's control, such as man-made or naturally occurring electrochemical oxidation or corrosion and/or metallic pollutants; normal wear and tear; inadequate, improper, or surges of electrical power; lightning, floods, fire, acts of God, war, terrorism, or other external causes, including Force Majeure.
 - d) Unauthorized modification including installation of third-party software on the Product.
 - e) Product modification or service by anyone other than: (a) the Company, (b) a Company-authorized service provider, or (c) Customer's own installation of Company approved parts with instruction from the Company. Service to a damaged or malfunctioning sign which has not been ordered or authorized by the Company's Customer Satisfaction Department is not covered under this Limited Warranty and will automatically invalidate this Limited Warranty.
 - f) Computer viruses, Trojan horses, worms, self-replicating code or like destructive code which was not included in the Product by the Company.
 - g) Products installed with known or visible manufacturing defects at the time of installation.
- 12) All items returned to the Company must have a Return Materials Authorization ("RMA") number, available by using the contact information below. Items received without an RMA number will not be processed and will be returned to the Customer at their expense. The Customer is responsible for sending any defective part to the Company, after which the Company will send a repaired or replacement part to the Customer.
- 13) The Company will provide and be responsible for the cost of shipping parts from the Company to the Customer, with the exception of sign faces replaced due to vandalism. Standard shipping via the United States Postal Service or other commercial parcel delivery company is the default method of delivery. Expedited delivery is available to the Customer at his or her expense. The Customer will provide and be responsible for the cost of shipping parts to the Company.
- 14) Warranty claims must be registered with the Company within thirty (30) days of damage or malfunction. To register a claim, the Customer must contact the Company at the location specified below and provide (a) his or her name and any other required contact information, (b) Product and purchase descriptions, and (c) the nature of the defect. The Company reserves the right (at its sole discretion) to require proof of original purchase (e.g. paid invoice, receipt) and to visit the site of the installation or to require documentation of the claim before assuming any responsibility under the provisions of this Limited Warranty.
- 15) THE LIMITED WARRANTIES SET FORTH HEREIN ARE THE ONLY WARRANTIES MADE BY THE COMPANY IN CONNECTION WITH THE PRODUCT. THE COMPANY CANNOT AND DOES NOT MAKE ANY IMPLIED OR EXPRESS WARRANTIES WITH RESPECT TO THE PRODUCT, AND DISCLAIMS ALL OTHER WARRANTIES, INCLUDING, BUT NOT LIMITED TO, ANY WARRANTY OF MERCHANTABILITY OR FITNESS FOR A PARTICULAR PURPOSE. THE COMPANY'S SOLE OBLIGATION UNDER THIS LIMITED WARRANTY SHALL BE TO REPAIR OR REPLACE MALFUNCTIONING OR DEFECTIVE PARTS OF THE PRODUCT. BUYER ASSUMES ALL RISK WHATSOEVER AS TO THE RESULT OF THE USE OF THE PRODUCT PURCHASED, WHETHER USED SINGULARLY OR IN COMBINATION WITH ANY OTHER PRODUCTS OR SUBSTANCES.
- 16) NO CLAIM BY BUYER OF ANY KIND, INCLUDING CLAIMS FOR INDEMNIFICATION, SHALL BE GREATER IN AMOUNT THAN THE PURCHASE PRICE OF THE PRODUCT WITH RESPECT TO WHICH DAMAGES ARE CLAIMED. IN NO EVENT SHALL COMPANY BE LIABLE TO BUYER IN TORT, CONTRACT OR OTHERWISE, FOR ANY SPECIAL, INDIRECT, INCIDENTAL, CONSEQUENTIAL, RELIANCE, PUNITIVE OR EXEMPLARY DAMAGES, OR FOR LOSS OF PROFIT, REVENUE OR USE, IN CONNECTION WITH, ARISING OUT OF, OR AS A RESULT OF, THE SALE, DELIVERY, SERVICING, USE OR LOSS OF USE OF THE PRODUCT SOLD HEREUNDER, OR FOR ANY LIABILITY THAT BUYER HAS TO ANY THIRD PARTY WITH RESPECT THERETO.

Contact Information:

Stewart Signs Customer Satisfaction
2201 Cantu Court, Suite 215
Sarasota, FL 34232
Phone: 855-841-4624
Web: www.stewartsigns.com/support/

GENERAL INFORMATION

The Facility Inspection Tool (FIT) has been developed by the Office of Public School Construction to determine if a school facility is in "good repair" as defined by Education Code (EC) Section 17002(d)(1) and to rate the facility pursuant to EC Section 17002(d)(2). The tool is designed to identify areas of a school site that are in need of repair based upon a visual inspection of the site. In addition, the EC specifies the tool should not be used to require capital enhancements beyond the standards to which the facility was designed and constructed.

Good repair is defined to mean that the facility is maintained in a manner that ensures that it is clean, safe, and functional. As part of the school accountability report card, school districts and county offices of education are required to make specified assessments of school conditions including the safety, cleanliness, and adequacy of school facilities and needed maintenance to ensure good repair. In addition, beginning with the 2005/2006 fiscal year, school districts and county offices of education must certify that a facility inspection system has been established to ensure that each of its facilities is maintained in good repair in order to participate in the School Facility Program and the Deferred Maintenance Program. This tool is intended to assist school districts and county offices of education in that determination.

County superintendents are required to annually visit the schools in the county of his or her office as determined by EC Section 1240. Further, EC Section 1240(c)(2)(I), states the priority objective of the visits made shall be to determine the status of the condition of a facility that poses an emergency or urgent threat to the health or safety of pupils or staff as defined in district policy, or as defined by EC Section 17592.72(c) and the accuracy of data reported on the school accountability report card with the respect to the safety, cleanliness, and adequacy of school facilities, including good repair as required by EC Sections 17014, 17032.5, 17070.75, and 17089. This tool is also intended to assist county offices of education in performing these functions.

The EC also allows individual entities to adopt a local evaluation instrument to be used in lieu of the FIT provided the local instrument meets the criteria specified in EC Section 17002(d) and as implemented in the FIT. Any evaluation instrument adopted by the local educational agency for purpose of determining whether a school facility is maintained in good repair may include any number of additional items but must minimally include the criteria and rating scheme contained in the FIT.

USER INSTRUCTIONS

The FIT is comprised of three parts as follows:

Part I, Good Repair Standard outlines the school facility systems and components, as specified in EC Section 17002(d)(1), that should be considered in the inspection of a school facility to ensure it is maintained in a manner that assures it is clean, safe and functional. Each of the 15 sections in the Good Repair Standard provides a description of a minimum standard of good repair for various school facility categories. Each section also provides examples of clean, safe and functional conditions. The list of examples is not exhaustive. If an evaluator notes a condition that is not mentioned in the examples but constitutes a deficiency, the evaluator can note such deficiency in the applicable category as "other."

Some of the conditions cited in the Good Repair Standard represent items that are critical to the health and safety of pupils and staff. Any deficiencies in these items require immediate attention and, if left unmitigated, could cause severe and immediate injury, illness or death of the occupants. They constitute extreme deficiencies and indicate that the particular building system evaluated failed to meet the standard of good repair at that school site. These critical conditions are identified with underlined text followed by an (X) on the Good Repair Standard. If the underlined statement is not true, then there is an extreme deficiency (to be marked as an "X" on the Evaluation Detail) resulting in a "poor" rating for the applicable category. It is important to note that the list of extreme deficiencies noted in the Good Repair Standard is not exhaustive. Any other deficiency not included in the criteria but meeting the definition above can be noted by the evaluator and generate a poor rating.

Part II, Evaluation Detail is a site inspection template to be used to evaluate the areas of a school on a category by category basis. The design of the inspection template allows for the determination of the scope of conditions across campus. In evaluating each area or space, the user should review each of the 15 categories identified in the Good Repair Standard and make a determination of whether a particular area is in good repair. Once the determination is made, it should be recorded on the Evaluation Detail, as follows:

✓	No Deficiency - Good Repair: Insert a check mark if all statements in the Good Repair Standard are true, and there is no indication of a deficiency in the specific category.
D	Deficiency: Mark "D" if one or more statement(s) in the Good Repair Standard for the specific category is not true, or if there is other clear evidence of the need for repair.
X	Extreme Deficiency: Indicate "X" if the area has a deficiency that is considered an "Extreme Deficiency" in the Good Repair Standard or there is a condition that qualifies as an extreme deficiency but is not noted in the Good Repair Standard.
NA	Not Applicable: If the Good Repair Standard category (building system or component) does not exist in the area evaluated, mark "NA."

PART I: GOOD REPAIR STANDARD

(X): If underlined statement is not true, then this is an extreme deficiency (marked as an "X") on the Evaluation Detail resulting in a "poor" rating for the applicable category.

207

Gas Leaks

Gas systems and pipes appear safe, functional, and free of leaks.

Examples include but are not limited to the following:

- a. There is no odor that would indicate a gas leak. (X)
- b. Gas pipes are not broken and appear to be in good working order. (X)
- c. Other

Mechanical Systems

Heating, ventilation, and air conditioning systems (HVAC) as applicable are functional and unobstructed. Examples include but are not limited to the following:

- a. The HVAC system is operable. (X)
- b. The facilities are ventilated (via mechanical or natural ventilation).
- c. The ventilation units are unobstructed and vents and grills are without evidence of excessive dirt or dust.
- d. There appears to be an adequate air supply to all classrooms, work spaces, and facilities (i.e. no strong odor is present, air is not stuffy)
- e. Interior temperatures appear to be maintained within normally accepted ranges.
- f. The ventilation units are not generating any excessive noise or vibrations.
- g. Other

Sewer

Sewer line stoppage is not evident. Examples include but are not limited to the following:

- a. There are no obvious signs of flooding caused by sewer line back-up in the facilities or on the school grounds. (X)
- b. The sanitary system controls odors as designed.
- c. Other

Interior Surfaces (Floors, Ceilings, Walls, and Window Casings)

Interior surfaces appear to be clean, safe, and functional. Examples include but are not limited to the following:

- a. Walls are free of hazards from tears and holes.
- b. Flooring is free of hazards from torn carpeting, missing floor tiles, holes.
- c. Ceiling is free of hazards from missing ceiling tiles and holes.
- d. There is no evidence of water damage (e.g. no condensation, dampness, staining, warping, peeling, mineral deposits, etc.)
- e. Other

Overall Cleanliness

School grounds, buildings, common areas, and individual rooms appear to have been cleaned regularly. Examples include but are not limited to the following:

- a. Area(s) evaluated is free of accumulated refuse, dirt, and grime.
- b. Area(s) evaluated is free of unabated graffiti.
- c. Restrooms, drinking fountains, and food preparation or serving areas appear to have been cleaned each day that school is in session.
- d. Other

Pest/Vermis Infestation

Pest or vermin infestation are not evident.

Examples include but are not limited to the following:

- a. There is no evidence of a major pest or vermin infestation. (X)
- b. There are no holes in the walls, floors, or ceilings.
- c. Rodent droppings or insect skins are not evident.
- d. Odor caused by a pest or vermin infestation is not evident.
- e. There are no live rodents observed.
- f. Other

Electrical (Interior and Exterior)

1. There is no evidence that any portion of the school has a power failure. (X)

2. Electrical systems, components, and equipment appear to be working properly. Examples include but are not limited to the following:

- a. There are no exposed electrical wires. Electrical equipment is properly covered and secured from pupil access. (X)
- b. Outlets, access panels, switch plates, junction boxes and fixtures are properly covered and secured from pupil access.
- c. Other

3. Lighting appears to be adequate and working properly, including exterior lights. Examples include but are not limited to the following:

- a. Lighting appears to be adequate.
- b. Lighting is not flickering.
- c. There is no unusual hum or noise from the light fixtures.
- d. Other

CATEGORY	Date of Inspection: 12/03/18 School Name: Gravenstein 1st														
	1	2	3	4	5	6	7	8	9	10	11	12	13	14	15
AREA	GAS LEAKS	MECH/HVAC	SEWER	INTERIOR SURFACES	OVERALL CLEANLINESS	PEST/TERMINI INFESTATION	ELECTRICAL	RESTROOM	SINKS/ FOUNTAINS	FIRE SAFETY	HAZARDOUS MATERIALS	STRUCTURAL DAMAGE	ROOFS	PLAYGROUND/ SCHOOL GROUNDS	WINDOWS/ DOORS/ GATEPENCES
Room TK	NA	✓	✓	✓	✓	✓	✓	✓	✓	✓	✓	✓	✓	✓	✓
	COMMENTS: Built 2009. Will be getting LED lighting upgrade part of prop 39.														
Rm 1	✓	✓	✓	✓	✓	✓	✓	✓	✓	✓	✓	✓	✓	✓	✓
	COMMENTS: Roofing done phase 1 summer 2015. Part of modernization in 2016. New restroom, Lighting, hvac, restained casework, new entryway tile. Fire Alarm														
Rm 2	✓	✓	✓	✓	✓	✓	✓	✓	✓	✓	✓	✓	✓	✓	✓
	COMMENTS: Roofing done phase 1 summer 2015. Part of modernization in 2016. New restroom, roofing, Lighting, hvac, restained casework, Fire Alarm														
Rm 3	✓	✓	✓	✓	✓	✓	✓	NA	✓	✓	✓	✓	✓	✓	✓
	COMMENTS: Roofing done phase 1 summer 2015. Part of modernization in 2016. Lighting, roofing, hvac, new sink, refinished cabinets, fire alarm														
Rm 4	✓	✓	✓	✓	✓	✓	✓	NA	✓	✓	✓	✓	✓	✓	✓
	COMMENTS: Roofing done phase 1 summer 2015. Part of modernization in 2016. Lighting, roofing, hvac, new sink, refinished cabinets, fire alarm														
Rm 5	✓	✓	✓	✓	✓	✓	✓	NA	✓	✓	✓	✓	✓	✓	D
	COMMENTS: Roofing done phase 1 summer 2015. Last Modernization 2007. Fire alarm updated 2016. Received new LED lighting in phase 3 modernization in summer 2018. Recommend new rear door.														
Rm 6	✓	✓	✓	✓	✓	✓	✓	NA	✓	✓	✓	✓	✓	✓	✓
	COMMENTS: Roofing done phase 1 summer 2015. Part of modernization in 2016. Lighting, hvac, new sink, refinished cabinets, fire alarm														
Rm 7	✓	✓	✓	✓	✓	✓	✓	NA	✓	✓	✓	✓	✓	✓	✓
	COMMENTS: Roofing done phase 1 summer 2015. Part of modernization in 2016. Lighting, hvac, new sink, refinished cabinets, fire alarm														
Rm 8	✓	✓	✓	✓	✓	✓	✓	NA	✓	✓	✓	✓	✓	✓	✓
	COMMENTS: Roofing done phase 1 summer 2015. Part of modernization in 2016. LED Lighting, hvac, new sink, refinished cabinets, fire alarm														
Rm 9	✓	✓	✓	✓	✓	✓	✓	NA	✓	✓	✓	✓	✓	✓	D
	COMMENTS: Roofing done phase 1 summer 2015. Part of modernization in 2016. Lighting, hvac, new sink, refinished cabinets, fire alarm. Recommend new rear door.														
Rm 10	✓	✓	✓	✓	✓	✓	✓	NA	✓	✓	✓	✓	✓	✓	✓
	COMMENTS: Part of modernization in 2016. LED Lighting, hvac, new sink, refinished cabinets, fire alarm. New carpet installed summer 2018.														
Rm 11	✓	✓	✓	✓	✓	✓	✓	NA	✓	✓	✓	✓	✓	✓	✓
	COMMENTS: Part of modernization in 2016. New Lighting, hvac, sink, refinished cabinets, fire alarm,														
Rm 12	✓	✓	✓	✓	✓	✓	✓	NA	✓	✓	✓	✓	✓	✓	✓
	COMMENTS: Part of modernization in 2016. New Lighting, hvac, sink, refinished cabinets, fire alarm,														

CATEGORY	PART II: EVALUATION DETAIL															
	1	2	3	4	5	6	7	8	9	10	11	12	13	14	15	
AREA	GAS LEAKS	MECH/HVAC	SEWER	INTERIOR SURFACES	OVERALL CLEANLINESS	PEST/VERMIN INFESTATION	ELECTRICAL	RESTROOM	SINKS/ FOUNTAINS	FIRE SAFETY	HAZARDOUS MATERIALS	STRUCTURAL DAMAGE	ROOFS	PLAYGROUND/ SCHOOL GROUNDS	WINDOWS/ DOORS/ GATES/FENCES	
Primary Restrooms	✓	✓	✓	✓	✓	✓	✓	✓	✓	✓	✓	✓	✓	✓	✓	
	COMMENTS: Restrooms completely remodeled in 2016 with new fixtures, tile, partitions, lighting, paint															
Intermediate Restrooms	✓	✓	✓	✓	✓	✓	✓	✓	✓	✓	✓	✓	✓	✓	D	
	COMMENTS: Restrooms completely remodeled in 2016 with new fixtures, tile, partitions, lighting, paint. New door for PE shed needed (To be done)															
MPR	✓	✓	✓	✓	✓	✓	✓	NA	✓	✓	✓	✓	✓	✓	D	
	COMMENTS: Received modernization including new roof, windows, flooring, pocket tables, lighting, paint, insulation in walls, new HVAC, new wheelchair lift. Needs exterior siding redone proposal to this in progress. Exterior door appears to leak (needs gasket)															
Admin	COMMENTS: Admin Building Remodel completed in 2017. New lighting, HVAC, Windows, Fire Alarm, Flooring, Paint, restrooms															
	✓	✓	✓	✓	✓	✓	✓	✓	✓	✓	✓	✓	✓	✓	✓	
COMMENTS: Received modernization new roof, new, carpet, staff restrooms, lighting, paint, HVAC, new windows, ceiling grid in summer 2018 part of Phase III. Proposed to get new exterior siding																
Learning Lab	NA	NA	NA	NA	✓	✓	NA	NA	✓	✓	✓	✓	NA	D	✓	
	COMMENTS: New shooks and swing chains installed. To add additional playground bark yearly. Ball wall needs repair (plan to fix)															
Primary Playground	NA	NA	NA	NA	✓	✓	NA	NA	✓	✓	✓	✓	NA	D	✓	
	COMMENTS: New shade structure for outdoor eating area added 2017. To be replacing all swing seats swing assemblies due to signs of wear. To be done soon. Add additional playground bark yearly.															
Rm K	✓	✓	✓	✓	✓	✓	✓	✓	✓	✓	✓	✓	✓	✓	✓	
	COMMENTS: Part of modernization in 2016. Lighting, new sink, new hvac, fire alarm, remodeled restroom.															
Kitchen	✓	✓	✓	✓	✓	✓	✓	NA	✓	✓	✓	✓	✓	✓	✓	
	COMMENTS: Received complete remodel summer 2018 part of phase III. New HVAC, floor, casework, paint, lighting, sinks, fire alarm.															

Marks: ✓ = Good Repair, D = Deficiency, X = Extreme Deficiency, NA = Not Applicable
 Use additional Area Lines as necessary.

SCHOOL DISTRICT/COUNTY/OFFICE OF EDUCATION		Gravenstein Union School District		COUNTY	Sonoma	
SCHOOL SITE		Gravenstein 1st		SCHOOL TYPE (GRADE LEVELS)	Tk-5th grade	
INSPECTOR NAME		Brian Sposato		INSPECTOR TITLE	Facilities Manager	
DATE OF INSPECTION		12/3/2018 7:30am		WEATHER CONDITION AT TIME OF INSPECTION	overcast 50 degrees	
NAME OF DISTRICT REPRESENTATIVE/ACCOMPANYING THE INSPECTOR(S) (IF APPLICABLE)				NUMBER OF CLASSROOMS ON SITE	27	

PART III: CATEGORY TOTALS AND RANKING (round all calculations to two decimal places)

TOTAL NUMBER OF AREAS EVALUATED	CATEGORY TOTALS	A. SYSTEMS			B. INTERIOR		C. CLEANLINESS		D. ELECTRICAL	E. RESTROOMS/FOUNTAINS		F. SAFETY		G. STRUCTURAL	H. EXTERNAL	
		PLUMBING	MECHANICAL	SEWER	INTERIOR SURFACES	OVERALL CLEANLINESS	PEST/VERMIN INFESTION	ELECTRICAL	RESTROOMS	SINKS/FOUNTAINS	FIREWEIGHT	HAZARDOUS MATERIALS	STRUCTURAL DAMAGE	PLAYGROUND/SCHOOL GROUNDS	WINDOWS/DOORS/GATES/FENCES	
35	Number of "V"s:	32	33	33	32	34	35	33	10	34	35	35	33	33	31	
	Number of "C"s:	0	0	0	1	1	0	0	0	1	0	0	0	2	4	
	Number of N/A's:	0	0	0	0	0	0	0	0	0	0	0	0	0	0	
Percent of System in Good Repair Number of "V"s divided by (Total Areas - "N/A's")		100.00%	100.00%	100.00%	96.97%	97.14%	100.00%	100.00%	100.00%	97.14%	100.00%	100.00%	100.00%	94.29%	88.57%	
Total Percent per Category (Average of above)*		100.00%			96.97%	98.57%	100.00%	100.00%	100.00%	98.57%	100.00%	100.00%	91.43%	GOOD		
Rank (Circle one) GOOD = 90%-100% FAIR = 75%-89.99% POOR = 0%-74.99%		GOOD			GOOD	GOOD	GOOD	GOOD	GOOD	GOOD	GOOD	GOOD	GOOD	GOOD		

*Note: An extreme deficiency in any area automatically results in a "poor" ranking for that category and a zero for "Total Percent per Category".

OVERALL RATING:

DETERMINE AVERAGE PERCENTAGE OF 8 CATEGORIES ABOVE SCHOOL RATING**

**For School Rating, apply the Percentage Range below to the average percentage determined above, taking into account the rating Description below.

PERCENTAGE	DESCRIPTION	RATING
99%-100%	The school meets most or all standards of good repair. Deficiencies noted, if any, are not significant and/or impact a very small area of the school.	EXEMPLARY
90%-98.99%	The school is maintained in good repair with a number of non-critical deficiencies noted. These deficiencies are isolated, and/or resulting from minor wear and tear, and/or in the process of being mitigated.	GOOD
75 %-89.99%	The school is not in good repair. Some deficiencies noted are critical and/or widespread. Repairs and/or additional maintenance are necessary in several areas of the school site.	FAIR
0%-74.99%	The school facilities are in poor condition. Deficiencies of various degrees have been noted throughout the site. Major repairs and maintenance are necessary throughout the campus.	POOR

COMMENTS AND RATING EXPLANATION:

Much of the campus received a modernization in 2016. This is noted as Phase 2 and includes new HVAC systems, new lightning, remodeled restrooms, new fire alarm and accessibility improvements.

Phase III modernization was started in 2018 included remodel of kitchen, mpr, learning lab, and new led lighting for six classrooms. Work order system in place to fix items as needed.

Solar is anticipated with roof array over buildings A and B. Anticipated to be spring of 2019.

Items marked for repair are planned to be remedied.

PART II: EVALUATION DETAIL Date of Inspection: **12/03/18**

School Name: **Gavenstein Elementary Charter**

AREA	CATEGORY	1	2	3	4	5	6	7	8	9	10	11	12	13	14	15
		GAS LEAKS	MECH/HVAC	SEWER	INTERIOR SURFACES	OVERALL CLEANLINESS	PEST/VERMIN INFESTATION	ELECTRICAL	RESTROOM	SINKS/ FOUNTAINS	FIRE SAFETY	HAZARDOUS MATERIALS	STRUCTURAL DAMAGE	ROOFS	PLAYGROUND/ SCHOOL GROUNDS	WINDOWS/ DOORS/ GATEWAYS
Room TK	NA	✓	✓	✓	✓	✓	✓	✓	✓	✓	✓	✓	✓	✓	✓	✓
	COMMENTS:	Built 2009. Will be getting LED lighting upgrade part of prop 39.														
Rm 1	✓	✓	✓	✓	✓	✓	✓	✓	✓	✓	✓	✓	✓	✓	✓	✓
	COMMENTS:	Roofing done phase 1 summer 2015. Part of modernization in 2016. New restroom, Lighting, hvac, restained casework, new entryway tile. Fire Alarm														
Rm 2	✓	✓	✓	✓	✓	✓	✓	✓	✓	✓	✓	✓	✓	✓	✓	✓
	COMMENTS:	Roofing done phase 1 summer 2015. Part of modernization in 2016. New restroom, roofing, Lighting, hvac, restained casework, Fire Alarm														
Rm 3	✓	✓	✓	✓	✓	✓	✓	✓	NA	✓	✓	✓	✓	✓	✓	✓
	COMMENTS:	Roofing done phase 1 summer 2015. Part of modernization in 2016. Lighting, roofing, hvac, new sink, refinished cabinets, fire alarm														
Rm 4	✓	✓	✓	✓	✓	✓	✓	✓	NA	✓	✓	✓	✓	✓	✓	✓
	COMMENTS:	Roofing done phase 1 summer 2015. Part of modernization in 2016. Lighting, roofing, hvac, new sink, refinished cabinets, fire alarm														
Rm 5	✓	✓	✓	✓	✓	✓	✓	✓	NA	✓	✓	✓	✓	✓	✓	D
	COMMENTS:	Roofing done phase 1 summer 2015. Last Modernization 2007. Fire alarm updated 2016. Received new LED lighting in phase 3 modernization in summer 2018. Recommend new rear door.														
Rm 6	✓	✓	✓	✓	✓	✓	✓	✓	NA	✓	✓	✓	✓	✓	✓	✓
	COMMENTS:	Roofing done phase 1 summer 2015. Part of modernization in 2016. Lighting, hvac, new sink, refinished cabinets, fire alarm														
Rm 7	✓	✓	✓	✓	✓	✓	✓	✓	NA	✓	✓	✓	✓	✓	✓	✓
	COMMENTS:	Roofing done phase 1 summer 2015. Part of modernization in 2016. Lighting, hvac, new sink, refinished cabinets, fire alarm														
Rm 8	✓	✓	✓	✓	✓	✓	✓	✓	NA	✓	✓	✓	✓	✓	✓	✓
	COMMENTS:	Roofing done phase 1 summer 2015. Part of modernization in 2016. LED Lighting, hvac, new sink, refinished cabinets, fire alarm														
Rm 9	✓	✓	✓	✓	✓	✓	✓	✓	NA	✓	✓	✓	✓	✓	✓	D
	COMMENTS:	Roofing done phase 1 summer 2015. Part of modernization in 2016. Lighting, hvac, new sink, refinished cabinets, fire alarm. Recommend new rear door.														
Rm 10	✓	✓	✓	✓	✓	✓	✓	✓	NA	✓	✓	✓	✓	✓	✓	✓
	COMMENTS:	Part of modernization in 2016. LED Lighting, hvac, new sink, refinished cabinets, fire alarm. New carpet installed summer 2018.														
Rm 11	✓	✓	✓	✓	✓	✓	✓	✓	NA	✓	✓	✓	✓	✓	✓	✓
	COMMENTS:	Part of modernization in 2016. New Lighting, hvac, sink, refinished cabinets, fire alarm,														
Rm 12	✓	✓	✓	✓	✓	✓	✓	✓	NA	✓	✓	✓	✓	✓	✓	✓
	COMMENTS:	Part of modernization in 2016. New Lighting, hvac, sink, refinished cabinets, fire alarm,														

PART II: EVALUATION DETAIL Date of Inspection: **12/03/18** School Name: **Gavenstein Elementary Charter**

AREA	CATEGORY	1	2	3	4	5	6	7	8	9	10	11	12	13	14	15
		GAS LEAKS	MECH/HVAC	SEWER	INTERIOR SURFACES	OVERALL CLEANLINESS	PEST/TERMIN INESTATION	ELECTRICAL	RESTROOM	SINKS/ FOUNTAINS	FIRE SAFETY	HAZARDOUS MATERIALS	STRUCTURAL DAMAGE	ROOFS	PLAYGROUND/ SCHOOL GROUNDS	WINDOWS/ DOORS/ GATES/FENCES
Primary Restrooms		✓	✓	✓	✓	✓	✓	✓	✓	✓	✓	✓	✓	✓	✓	✓
	COMMENTS:	Restrooms completely remodeled in 2016 with new fixtures, tile, partitions, lighting, paint														
Intermediate Restrooms		✓	✓	✓	✓	✓	✓	✓	✓	✓	✓	✓	✓	✓	✓	D
	COMMENTS:	Restrooms completely remodeled in 2016 with new fixtures, tile, partitions, lighting, paint. New door for PE shed needed (To be done)														
MPR		✓	✓	✓	✓	✓	✓	✓	NA	✓	✓	✓	✓	✓	✓	D
	COMMENTS:	Received modernization including new roof, windows, flooring, pocket tables, lighting, paint, insulation in walls, new HVAC, new wheelchair lift. Needs exterior siding redone proposal to this in progress. Exterior door appears to leak (needs gasket)														
Admin		✓	✓	✓	✓	✓	✓	✓	✓	✓	✓	✓	✓	✓	✓	✓
	COMMENTS:	Admin Building Remodel completed in 2017. New lighting, HVAC, Windows, Fire Alarm, Flooring, Paint, restrooms														
Learning Lab		✓	✓	✓	✓	✓	✓	✓	✓	✓	✓	✓	✓	✓	✓	✓
	COMMENTS:	Received modernization new roof, new, carpet, staff restrooms, lighting, paint, HVAC, new windows, ceiling grid in summer 2018 part of Phase III. Proposed to get new exterior siding														
Primary Playground		NA	NA	NA	NA	✓	✓	NA	NA	✓	✓	✓	✓	NA	D	✓
	COMMENTS:	New shocks and swing chains installed. To add additional playground bark yearly. Ball wall needs repair (plan to fix)														
Intermediate Playground		NA	NA	NA	NA	✓	✓	NA	NA	✓	✓	✓	✓	NA	D	✓
	COMMENTS:	New shade structure for outdoor eating area added 2017. To be replacing all swing seats swing assemblies due to signs or wear. To be done soon. Add additional playground bark yearly.														
Rm K		✓	✓	✓	✓	✓	✓	✓	✓	✓	✓	✓	✓	✓	✓	✓
	COMMENTS:	Part of modernization in 2016. Lighting, new sink, new hvac, fire alarm, remodeled restroom.														
Kitchen		✓	✓	✓	✓	✓	✓	✓	NA	✓	✓	✓	✓	✓	✓	✓
	COMMENTS:	Received complete remodel summer 2018 part of phase III. New HVAC, floor, casework, paint, lighting, sinks, fire alarm.														

Marks: ✓ = Good Repair. D = Deficiency. X = Extreme Deficiency. NA = Not Applicable
 Use additional Area Lines as necessary.

SCHOOL DISTRICT/COUNTY OFFICE OF EDUCATION		COUNTY	
Gravenstein Union School District		Sonoma	
SCHOOL SITE		SCHOOL TYPE (GRADE LEVELS)	
Gravenstein Elementary Charter		TK-5th grade	
INSPECTOR'S NAME		NAME OF DISTRICT REPRESENTATIVE ACCOMPANYING THE INSPECTOR(S) (IF APPLICABLE)	
Brian Sposato		27	
TIME OF INSPECTION		WEATHER CONDITION AT TIME OF INSPECTION	
12/3/2018 7:30am		Overcast 50 degrees	
INSPECTOR'S TITLE		FACILITIES TITLE	
Facilities Manager		Facilities Manager	

PART III: CATEGORY TOTALS AND RANKING (round all calculations to two decimal places)

TOTAL NUMBER OF AREAS EVALUATED	CATEGORY TOTALS	A. SYSTEMS		B. INTERIOR	C. CLEANLINESS		D. ELECTRICAL	E. RESTROOMS/FOUNTAINS		F. SAFETY		G. STRUCTURAL	H. EXTERNAL			
		GAS LEAKS	MECH/HVAC	SEWER	INTERIOR SURFACES	OVERALL CLEANLINESS	PEST/VERMIN INFESTATION	ELECTRICAL	RESTROOMS	SINKS/FOUNTAINS	FIRE SAFETY	HAZARDOUS MATERIALS	STRUCTURAL DAMAGE	ROOFS	PLAYGROUND/SCHOOL GROUNDS	WINDOW/SPOORS/GATEPENCES
35	↓	Number of "✓'s":	32	33	33	34	35	33	10	34	35	35	33	33	31	
		Number of "D's":	0	0	0	1	1	0	0	0	1	0	0	0	2	4
		Number of "X's":	0	0	0	0	0	0	0	0	0	0	0	0	0	0
Percent of System in Good Repair (Total Areas - "N/A's")		100.00%		100.00%		96.97%		97.14%		100.00%		100.00%		94.29%		
Total Percent per Category (average of above)*		100.00%		96.97%		98.57%		100.00%		98.57%		100.00%		91.43%		
Rank (Circle one) GOOD = 90%-100% FAIR = 75%-89.99% POOR = 0%-74.99%		GOOD		GOOD		GOOD		GOOD		GOOD		GOOD		GOOD		

*Note: An extreme deficiency in any area automatically results in a "poor" ranking for that category and a zero for "Total Percent per Category".

OVERALL RATING:

DETERMINE AVERAGE PERCENTAGE OF 8 CATEGORIES ABOVE → 98.19% SCHOOL RATING** → GOOD

**For School Rating, apply the Percentage Range below to the average percentage determined above, taking into account the rating Description below.

PERCENTAGE	DESCRIPTION	RATING
99%-100%	The school meets most or all standards of good repair. Deficiencies noted, if any, are not significant and/or impact a very small area of the school.	EXEMPLARY
90%-98.99%	The school is maintained in good repair with a number of non-critical deficiencies noted. These deficiencies are isolated, and/or resulting from minor wear and tear, and/or in the process of being mitigated.	GOOD
75%-89.99%	The school is not in good repair. Some deficiencies noted are critical and/or widespread. Repairs and/or additional maintenance are necessary in several areas of the school site.	FAIR
0%-74.99%	The school facilities are in poor condition. Deficiencies of various degrees have been noted throughout the site. Major repairs and maintenance are necessary throughout the campus.	POOR

COMMENTS AND RATING EXPLANATION:

Much of the campus received a modernization in 2016. This is noted as Phase 2 and includes new HVAC systems, new lightning, remodeled restrooms, new fire alarm and accessibility improvements.

Phase III modernization was started in 2018 included remodel of kitchen, mpr, learning lab, and new led lighting for six classrooms. Work order system in place to fix items as needed.

Solar is anticipated with roof array over buildings A and B. Anticipated to be spring of 2019.

Items marked for repair are planned to be remedied.

PART II: EVALUATION DETAIL		Date of Inspection: 1/13/018													School Name: Community Day School at Hillcrest Middle School	
CATEGORY	AREA	1	2	3	4	5	6	7	8	9	10	11	12	13	14	15
		GAS LEAKS	MECH/VAC	SEWER	INTERIOR SURFACES	OVERALL CLEANLINESS	PEST/VERMIN INFESTATION	ELECTRICAL	RESTROOM	SINKS/ FOUNTAINS	FIRE SAFETY	HAZARDOUS MATERIALS	STRUCTURAL DAMAGE	ROOFS	PLAYGROUND/ SCHOOL GROUNDS	WINDOWS/ DOORS/ GATES/FENCES
Room 1	COMMENTS:	Modernized in 2007. Will be receiving new LED lighting through prop 39.														
	✓	✓	✓	✓	✓	✓	✓	✓	NA	✓	✓	✓	✓	✓	✓	✓
Room 2	COMMENTS:	Modernized in 2007. Will be receiving new LED lighting through prop 39.														
	✓	✓	✓	✓	✓	✓	✓	✓	NA	✓	✓	✓	✓	✓	✓	✓
Room 3	COMMENTS:	Modernized in 2007. Will be receiving new LED lighting through prop 39.														
	✓	✓	✓	✓	✓	✓	✓	✓	NA	✓	✓	✓	✓	✓	✓	✓
Room 4	COMMENTS:	Modernized in 2007. Will be receiving new LED lighting through prop 39.														
	✓	✓	✓	✓	✓	✓	✓	✓	NA	✓	✓	✓	✓	✓	✓	✓
Room 5 Stream Lab	COMMENTS:	Modernized in 2007. Will be receiving new LED lighting through prop 39.														
	✓	✓	✓	✓	✓	✓	✓	✓	NA	✓	✓	✓	✓	✓	✓	✓
Room 6 Stream Lab/Library	COMMENTS:	Modernized in 2007. Will be receiving new LED lighting through prop 39.														
	✓	✓	✓	✓	✓	✓	✓	✓	NA	✓	✓	✓	✓	✓	✓	✓
Room 7	COMMENTS:	Last Modernized in 2007. Will be receiving new LED lighting through prop 39.														
	✓	✓	✓	✓	✓	✓	✓	✓	NA	✓	✓	✓	✓	✓	✓	✓
Room 8	COMMENTS:	Modernized in 2007. Will be receiving new LED lighting through prop 39.														
	✓	✓	✓	✓	✓	✓	✓	✓	NA	✓	✓	✓	✓	✓	✓	✓
Room 9	COMMENTS:	Modernized in 2007. Will be receiving new LED lighting through prop 39.														
	✓	✓	✓	✓	✓	✓	✓	✓	NA	✓	✓	✓	✓	✓	✓	✓
Room 10	COMMENTS:	Modernized in 2007. Will be receiving new LED lighting through prop 39. Concrete by exterior classroom is uneven from redwood tree roots, needs to be repaired.														
	✓	✓	✓	✓	✓	✓	✓	✓	NA	✓	✓	✓	✓	✓	D	✓
Room 11	COMMENTS:	Modernized in 2007. Will be receiving new LED lighting through prop 39. Exterior door needs closer (to be done)														
	✓	✓	✓	✓	✓	✓	✓	✓	NA	✓	✓	✓	✓	✓	✓	D
Room 12	COMMENTS:	Modernized in 2007. Will be receiving new LED lighting through prop 39.														
	✓	✓	✓	✓	✓	✓	✓	✓	NA	✓	✓	✓	✓	✓	✓	✓
Room 15 Staff Room	COMMENTS:	Received new LED lighting in summer 2016.														
	✓	✓	✓	✓	✓	✓	✓	✓	NA	✓	✓	✓	✓	✓	✓	✓

PART II: EVALUATION DETAIL		Date of Inspection: 11/30/18		School Name: Community Day School at Hillcrest Middle School												
AREA	CATEGORY	1	2	3	4	5	6	7	8	9	10	11	12	13	14	15
		GAS LEAKS	MECH/HVAC	SEWER	INTERIOR SURFACES	OVERALL CLEANLINESS	PEST/VERMIN INFESTATION	ELECTRICAL	RESTROOM	SINKS/ FOUNTAINS	FIRE SAFETY	HAZARDOUS MATERIALS	STRUCTURAL DAMAGE	ROOFS	PLAYGROUND/ SCHOOL GROUNDS	WINDOWS/ DOORS/ GATES/FENCES
Playground	✓	NA	NA	NA	NA	✓	✓	NA	NA	NA	✓	✓	✓	NA	D	✓
	COMMENTS:	New accessible pathway constructed in summer 2018. Playground could use updating. Summer 2019? border on playground has become seperated.														

Marks: ✓ = Good Repair. D = Deficiency. X = Extreme Deficiency. NA = Not Applicable
 Use additional Area Lines as necessary.

SCHOOL DISTRICT/COUNTY OFFICE OF EDUCATION		COUNTY	Sonoma
Gravenstein Union School District		SCHOOL TYPE (GRADE LEVELS)	6-8th
SCHOOL SITE		NUMBER OF CLASSROOMS ON SITE	18
Community Day School at Hillcrest Middle School		NAME OF DISTRICT REPRESENTATIVE ACCOMPANYING THE INSPECTOR(S) (IF APPLICABLE)	
INSPECTOR'S NAME		INSPECTOR'S TITLE	Facilities Manager
Inspector: Brian Sposato		WEATHER CONDITION AT TIME OF INSPECTION	
TIME OF INSPECTION		11/30/2018 9:30am	
		Overcast 50 degrees	

PART III: CATEGORY TOTALS AND RANKING (round all calculations to two decimal places)

TOTAL NUMBER OF AREAS EVALUATED	CATEGORY TOTALS	A. SYSTEMS			B. INTERIOR SURFACES	C. CLEANLINESS		D. ELECTRICAL	E. RESTROOMS/FOUNTAINS		F. SAFETY		G. STRUCTURAL		H. EXTERNAL	
		GAS LEAKS	MECH/HVAC	SEWER		OVERALL CLEANLINESS	PEST/VERMIN INFESTATION		ELECTRICAL	RESTROOMS	SINKS/FOUNTAINS	FIRE SAFETY	HAZARDOUS MATERIALS	STRUCTURAL DAMAGE	ROOFS	PLAYGROUND/SCHOOL GROUNDS
27	Number of "A"s:	27	24	26	24	27	27	26	3	26	27	27	27	24	24	26
	Number of "B"s:	0	2	0	2	0	0	0	0	0	0	0	0	2	3	1
	Number of "C"s:	0	0	0	0	0	0	0	0	0	0	0	0	0	0	0
Percent of System in Good Repair (Number of "A"s divided by Total Areas - "NA's")*		100.00%	92.31%	100.00%	92.31%	100.00%	100.00%	100.00%	100.00%	100.00%	100.00%	100.00%	100.00%	92.31%	88.89%	96.30%
Total Percent per Category (average of above)*		97.44%			92.31%	100.00%		100.00%	100.00%		100.00%	96.16%		92.60%		
Rank (Circle one) GOOD = 90%-100% FAIR = 75%-89.99% POOR = 0%-74.99%		GOOD														

*Note: An extreme deficiency in any area automatically results in a "poor" ranking for that category and a zero for "Total Percent per Category".

OVERALL RATING: **DETERMINE AVERAGE PERCENTAGE OF 8 CATEGORIES ABOVE** → **97.31%** **SCHOOL RATING**** → **GOOD**

**For School Rating, apply the Percentage Range below to the average percentage determined above, taking into account the rating Description below.

PERCENTAGE	DESCRIPTION	RATING
99%-100%	The school meets most or all standards of good repair. Deficiencies noted, if any, are not significant and/or impact a very small area of the school.	EXEMPLARY
90%-98.99%	The school is maintained in good repair with a number of non-critical deficiencies noted. These deficiencies are isolated, and/or resulting from minor wear and tear, and/or in the process of being mitigated.	GOOD
75 %-89.99%	The school is not in good repair. Some deficiencies noted are critical and/or widespread. Repairs and/or additional maintenance are necessary in several areas of the school site.	FAIR
0%-74.99%	The school facilities are in poor condition. Deficiencies of various degrees have been noted throughout the site. Major repairs and maintenance are necessary throughout the campus.	POOR

COMMENTS AND RATING EXPLANATION: Much of the campus received a modernization in 2007, which included new windows, heaters, sinks and casework. Campus wide Fire alarm upgraded in 2015 in conjunction with the construction of the science and performing arts building.

New main electrical switchgear, new led lighting in hallways and accessibility improvements to soccerfield done in summer 2018. New fence enclosures for utility mains. Prop 39 project to incorporate new LED lighting in many of the classrooms. Scheduled for new Solar parking structure in summer 2019.

While no leaks are present, tar and gravel roofs over buildings A and B were last done in 1988, consider for future replacement. Work order system in place to correct items that need attention or repair.

PART II: EVALUATION DETAIL		Date of Inspection: 11/30/18										School Name: Hillcrest Middle School Charter				
CATEGORY	AREA	1	2	3	4	5	6	7	8	9	10	11	12	13	14	15
		GAS LEAKS	MECH/HVAC	SEWER	INTERIOR SURFACES	OVERALL CLEANLINESS	PEST/VERMIN INFESTATION	ELECTRICAL	RESTROOM	SINKS/ FOUNTAINS	FIRE SAFETY	HAZARDOUS MATERIALS	STRUCTURAL DAMAGE	ROOFS	PLAYGROUND/ SCHOOL GROUNDS	WINDOWS/ DOORS/ GATEFENCES
A-wing work room /school office		✓	D	✓	✓	✓	✓	✓	NA	✓	✓	✓	✓	✓	✓	✓
	COMMENTS:	Received new LED Lighting and ceiling grid part of Hillcrest School Improvements summer 2018. Has older electrical wall heater (recommend to replace)														
B-wing locker room hallway end office		✓	✓	✓	✓	✓	✓	✓	NA	✓	✓	✓	✓	✓	✓	✓
	COMMENTS:	Received new LED Lighting and ceiling grid part of Hillcrest School Improvements summer 2018														
C-wing hallway		✓	✓	✓	✓	✓	✓	✓	NA	✓	✓	✓	✓	✓	✓	✓
	COMMENTS:	Received new LED Lighting and ceiling grid part of Hillcrest School Improvements summer 2018														
Principal's Office		✓	D	✓	✓	✓	✓	✓	NA	✓	✓	✓	✓	✓	✓	✓
	COMMENTS:	Received new LED lighting in summer 2017. No hardwired heater in room														
Gym		✓	✓	✓	✓	✓	✓	✓	✓	✓	✓	✓	✓	D	✓	✓
	COMMENTS:	Gym constructed in 2000. To be receiving new LED lighting both inside and outside part of prop 39 improvements. Small roof leak detected at attic space in gym (to be repaired) fascia needs to be painted on west side.														
Kitchen		✓	✓	✓	D	✓	✓	✓	NA	✓	✓	✓	✓	✓	✓	✓
	COMMENTS:	Kitchen constructed in 2000. To be receiving new LED lighting part of prop 39 improvements.														
P1		✓	✓	✓	✓	✓	✓	✓	NA	✓	✓	✓	✓	✓	✓	✓
	COMMENTS:	Modular built 2012. To be receiving new LED lighting part of prop 39 improvements.														
P2		✓	✓	✓	✓	✓	✓	✓	NA	✓	✓	✓	✓	✓	✓	✓
	COMMENTS:	Modular built 2012. To be receiving new LED lighting part of prop 39 improvements.														
Room 16 Science Room		✓	✓	✓	✓	✓	✓	✓	NA	✓	✓	✓	✓	✓	✓	✓
	COMMENTS:	Built in 2015. to be receiving new LED lighting part of prop 39. Storm drain drains slowly (Recommend digging up and replacement)														
Room 17 Music Room		✓	✓	✓	✓	✓	✓	✓	NA	✓	✓	✓	✓	✓	✓	✓
	COMMENTS:	Built in 2015. To be receiving new LED lighting part of prop 39 improvements.														
Portable Classroom Rm 18		✓	✓	✓	D	✓	✓	✓	NA	✓	✓	✓	✓	D	✓	✓
	COMMENTS:	Built in 1997. Will be receiving new LED lighting part of prop 39. Needs new gutter and downspouts. Has clutter of excess furniture (to be remedied)														
A building restrooms		✓	✓	✓	✓	✓	✓	✓	✓	✓	✓	✓	✓	✓	✓	✓
	COMMENTS:	Modernized in 2007. New LED lighting to be added part of prop 39. New exterior drinking fountains installed 2018														
B building restrooms		✓	✓	✓	✓	✓	✓	✓	✓	✓	✓	✓	✓	✓	✓	✓
	COMMENTS:	Modernized in 2007. New LED lighting to be added part of prop 39.														

PART II: EVALUATION DETAIL

Date of Inspection: **11/30/18**

School Name: **Hillcrest Middle School Charter**

CATEGORY	1	2	3	4	5	6	7	8	9	10	11	12	13	14	15
	GAS LEAKS	MECH/HVAC	SEWER	INTERIOR SURFACES	OVERALL CLEANLINESS	PEST/VERMIN INFESTATION	ELECTRICAL	RESTROOM	SINKS/ FOUNTAINS	FIRE SAFETY	HAZARDOUS MATERIALS	STRUCTURAL DAMAGE	ROOFS	PLAYGROUND/ SCHOOL GROUNDS	WINDOWS/ DOORS/ GATES/FENCES
Playground	✓	NA	NA	NA	✓	✓	NA	NA	NA	✓	✓	✓	NA	D	✓
COMMENTS: New accessible pathway constructed in summer 2018. Playground could use updating. Summer 2019? border on playground has become seperated.															

Marks: ✓ = Good Repair. D = Deficiency. X = Extreme Deficiency. NA = Not Applicable
 Use additional Area Lines as necessary.

SCHOOL DISTRICT/COUNTY OFFICE OF EDUCATION Gravenstein Union School District	COUNTY Sonoma
SCHOOL SITE Hillcrest Middle School Charter	SCHOOL TYPE (GRADE LEVEL(S)) 6-8th
INSPECTOR'S NAME Brian Spasato	INSPECTOR'S TITLE Facilities Manager
INSPECTOR'S TITLE Facilities Manager	NUMBER OF CLASSROOMS ON SITE 18
TIME OF INSPECTION 11/30/2018 9:30am	WEATHER CONDITION AT TIME OF INSPECTION Overcast 50 degrees
NAME OF DISTRICT REPRESENTATIVE ACCOMPANYING THE INSPECTOR(S) (IF APPLICABLE)	

PART III: CATEGORY TOTALS AND RANKING (round all calculations to two decimal places)

TOTAL NUMBER OF AREAS EVALUATED	CATEGORY TOTALS	A. SYSTEMS			B. INTERIOR	C. CLEANLINESS		D. ELECTRICAL	E. RESTROOMS/FOUNTAINS		F. SAFETY		G. STRUCTURAL		H. EXTERNAL	
		GAS LEAKS	MECH/VAC	SEWER	INTERIOR SURFACES	OVERALL CLEANLINESS	PEST/VERMIN INFESTATION	ELECTRICAL	RESTROOMS	SINKS/ FOUNTAINS	FIRE SAFETY	HAZARDOUS MATERIALS	STRUCTURAL DAMAGE	ROOFS	PLAYGROUND/ SCHOOL GROUNDS	W/INDOW/SIDWORS/ GATEPINES
27	Number of "✓" s:	27	24	26	24	27	27	26	3	26	27	27	24	24	26	
0	Number of "D" s:	0	2	0	2	0	0	0	0	0	0	0	0	2	3	
0	Number of "X" s:	0	0	0	0	0	0	0	0	0	0	0	0	0	0	
27	Number of N/A's:	0	1	1	1	0	1	24	1	0	0	0	1	0	0	
Percent of System in Good Repair Number of "✓" s divided by (Total Areas - "NA" s)*		100.00%	92.31%	100.00%	92.31%	100.00%	100.00%	100.00%	100.00%	100.00%	100.00%	100.00%	92.31%	88.89%	96.30%	
Total Percent per Category (average of above)*		97.44%			92.31%	100.00%	100.00%	100.00%	100.00%	100.00%	100.00%	96.16%	92.60%			
Rank (Circle one) GOOD = 90%-100% FAIR = 75%-89.99% POOR = 0%-74.99%		GOOD			GOOD	GOOD	GOOD	GOOD	GOOD	GOOD	GOOD	GOOD	GOOD	GOOD	GOOD	

*Note: An extreme deficiency in any area automatically results in a "poor" ranking for that category and a zero for "Total Percent per Category".

OVERALL RATING: **DETERMINE AVERAGE PERCENTAGE OF 8 CATEGORIES ABOVE** **SCHOOL RATING****

**For School Rating, apply the Percentage Range below to the average percentage determined above, taking into account the rating Description below.

PERCENTAGE	DESCRIPTION	RATING
99%-100%	The school meets most or all standards of good repair. Deficiencies noted, if any, are not significant and/or impact a very small area of the school.	EXEMPLARY
90%-98.99%	The school is maintained in good repair with a number of non-critical deficiencies noted. These deficiencies are isolated, and/or resulting from minor wear and tear, and/or in the process of being mitigated.	GOOD
75 %-89.99%	The school is not in good repair. Some deficiencies noted are critical and/or widespread. Repairs and/or additional maintenance are necessary in several areas of the school site.	FAIR
0%-74.99%	The school facilities are in poor condition. Deficiencies of various degrees have been noted throughout the site. Major repairs and maintenance are necessary throughout the campus.	POOR

COMMENTS AND RATING EXPLANATION:

Much of the campus received a modernization in 2007, which included new windows, heaters, sinks and casework. Campus wide Fire alarm upgraded in 2015 in conjunction with the construction of the science and performing arts building.

New main electrical switchgear, new led lighting in hallways and accessibility improvements to soccerfield done in summer 2018. New fence enclosures for utility mains.

Prop 39 project to incorporate new LED lighting in many of the classrooms. Scheduled for new Solar parking structure in summer 2019.

While no leaks are present, tar and gravel roofs over buildings A and B were last done in 1988, consider for future replacement. Work order system in place to correct items that need attention or repair.

Memorandum of Understanding between the Gravenstein Union School District and the Gravenstein Schools Magnet Program Foundation

Fiscal Year Ending June 30, 2019

PARTIES: The parties to this Memorandum of Understanding (hereafter "MOU" or "Agreement") are the Gravenstein Union School District (District) and the Gravenstein Schools Magnet Program Foundation (MPF). The District and the MPF warrant that the individuals executing this Agreement have the authority to bind the parties.

TERMINATION AND RENEWAL OF AGREEMENT: Except as otherwise specified below, this Agreement covers the entirety of the 2018-19 school year. Because of changes being made to the ENRICH! and Traditional Programs on an ongoing basis by the District, the parties do not currently anticipate yearly rolling renewal of this Agreement. The renewal of this Agreement must be completed by June 1st in the year in which the Agreement expires, or such other date as the parties may mutually agree upon.

UNDERSTANDINGS:

- The Magnet Program Foundation (MPF) is the non-profit foundation dedicated to advising, financially supporting and enhancing the ENRICH! Program in the Gravenstein Union School District. The ENRICH! Program is an extended day accelerated learning program that allows for daily courses in addition to the core curriculum in such areas as hands on science, art, drama, dance, poetry and physical education. The ENRICH! Program also provides for regular field trips supporting the curriculum at each grade level from 1st through 8th grades. The ENRICH! Program currently adds approximately 40 minutes to each participating student's school day.
- To aid in District planning, the MPF agrees to provide the Superintendent and GUSD Board with the most recent financial reporting upon request.
- The MPF agrees that all funds raised by the MPF are and will be used for the benefit of students enrolled in the District's creative arts Magnet Program in accordance with Education Code 51521.
- The MPF will maintain Directors' and Officers' liability insurance in the amount of at least \$1,000,000. The MPF will provide the District with certificates of insurance for all insurance policies.
- The GUSD Board of Trustees took action at its June 20, 2018 meeting to utilize the services of current ENRICH! contractors to also teach enrichment courses for students in the 1st through 5th grades in the Traditional program during the 2018-2019 school year. At the same meeting, the GUSD Board of Trustees also took action to extend by ten minutes the student day for Traditional program students at Gravenstein Elementary School in the 1st through 5th grades in order to accommodate those enrichment courses. The MPF understands that, at present, it is the intention of the GUSD Board of Trustees to offer one 45 minute enrichment course per week for every 1st through 5th grade class at Gravenstein Elementary School. These actions by the GUSD Board of Trustees create issues for the MPF affecting this MOU, specifically the following:
 1. Equal payment among students: The District is obligated to pay equal amounts for time spent by contractors teaching Traditional and ENRICH! programs.
 2. The stipend provided by MPF to ENRICH! teachers: The MPF understands that the issue of compensation for Traditional program teachers for the extra classroom time has been negotiated between GUTA (the teacher's union) and the District. 1st through 5th grade teachers in the Traditional program will be paid an additional stipend by the District. The District will provide a partial credit to the MPF in an amount equal to the stipend paid by the District to 1st through 5th

Deleted: <#>The MPF agrees that it will fulfill all requirements of a school-connected organization in accordance with District Board Policy/Administrative Regulation 1230. ^h

grade teachers in the Traditional program, as set forth in the section below entitled "Schedule of Reimbursements to the District."

3. Payment processing and fingerprinting of enrichment contractors will be assumed by the District: The District will invoice MPF each trimester for the cost of enrichment contractor expenses, less the amount paid for enrichment instruction to Traditional classes in the 1st through 5th grades. All said contractors will be subject to District policies and regulations. The District will assume responsibility for processing and fingerprinting all contractors at District expense prior to contact with students.
- Under District supervision, the MPF may supply additional instructional materials at the MPF expense. Materials purchased by MPF for use by the Magnet Program students or classrooms constitute donations to the District specifically for the benefit of the Magnet Program.
 - The District Superintendent will supervise the Magnet Program curriculum and materials, which will follow the California State Board of Education approved Standards.
 - Magnet Program students are enrolled in the District and are subject to District policies and regulations.
 - The District will employ and supervise the Magnet Program Director and all certificated program teachers, who will receive District benefits and be subject to District policies and regulations.
 - The District will provide Magnet Program students and classrooms with equivalent instructional materials and equipment as other District students and classrooms in similar grade levels.
 - The Magnet Program class size in grades 1-3 is the same as the Traditional program. The District's goal for the Magnet Program in grades 4-8 is a class size of 24 to 26 students.
- I. SCHEDULE OF REIMBURSEMENTS TO THE DISTRICT: The MPF agrees to contribute the following reimbursements to the District:
- Reimbursement of Magnet Program teacher stipends: The District will pay a stipend not to exceed \$2,500 per teacher, per classroom, for the 2018-19 school year to each core Magnet Program teacher to compensate for the extra time spent during the longer school day for Magnet Program students, and some additional duties outlined in an MOU between GUTA and GUSD. The MPF agrees to reimburse the District for these stipends in three equal installments at the end of each trimester, less the amount the District currently pays 1st through 5th grade teachers in the Traditional program for the extended day for their students. The stipend currently paid to 1st through 5th grade teachers in the Traditional program is 22% of the stipend to be paid to Magnet Program teachers, or \$550.00 based upon a \$2,500.00 stipend. Thus, based upon a \$2,500.00 stipend, MPF will reimburse the District in the amount of \$2,500.00 for each Magnet Program teacher at Hillcrest Middle School, and \$1,950.00 for each Magnet Program teacher in the 1st through 5th grades at Gravenstein Elementary School.
 - Reimbursement for Spanish instruction: The MPF agrees to reimburse the District for the cost of grades 1-5 Spanish enrichment provided to the Magnet Program students at Gravenstein Elementary. The cost of reimbursement for the 2018-19 school year will not exceed \$46,695.91. The MPF agrees to pay this reimbursement in three equal installments within 30 days of each trimester's invoice from the District. Should salary or benefit changes affect the total expenditure the District will notify MPF of the changes promptly and a solution will be negotiated.

- Field trip Block Grant: A variety of unique fieldtrips have been an integral part of the Magnet Program. Fieldtrips that take place or begin during the instructional day are considered District fieldtrips and must be approved by the District Superintendent. The MPF has been provided with a budget by the District for the “ENRICH! only” fieldtrips. Based upon this budget, the MPF agrees to support the cost of Magnet Program field trips in the following ways:
 - MPF will provide the District with a field trip block grant at a rate of \$22,000 per trimester, not to exceed \$68,000, to provide support for Magnet Program field trips. Field trip support includes, but is not limited to, transportation, tickets & registration fees, parking, food and supplies, additional contracted services, the cost of chaperones and overnight stipends for ENRICH! only field trips. Funding for field trips beyond the \$68,000 cap may be requested, and the MPF Board will consider the request, if funds are available. Should block grant funds exceed annual expenditures a refund will be made to MPF.
 - The District shall supply a quarterly field trip funds accounting report with appropriate 3rd party documentation for all ENRICH! field trip within 30 days of the end of the fiscal quarter.

DISTRICT REPORTING TO MPF: The District agrees to provide the following to the MPF:

- Monthly Program classroom enrollment information which will include a listing of all students currently enrolled in the Program at the end of the monthly reporting period.
- The District, on a monthly basis, shall make payment to contractors for the full amount of approved services provided by contractors to both Traditional and ENRICH! classrooms. The District shall then provide MPF with monthly statements concerning all work performed by contractors in both Traditional and ENRICH! classrooms, showing the number of hours, amount paid to each contractor, and invoices submitted by contractors for work performed in both Traditional and ENRICH! classrooms. The District shall be responsible for instituting a system by which time spent for instruction in ENRICH! and Traditional classrooms is tracked by the District so that the MPF can on a monthly basis know the net amount of compensation due by the MPF. Payment from the MPF to the District will be due within 30 days of the receipt of the invoice from the District unless objection is made by the MPF to particular charges.
- By Sept 15, the District will provide a final invoice to the MPF for all outstanding expenses from the Enrich! program for the previous fiscal year. The District agrees not to bill the MPF for expenses after that final invoice for the prior fiscal year.
- Each trimester, invoices detailing amounts payable to the District for program expenditures will be supported with appropriate third-party backup documentation, such as vendor invoices, for items not covered by the field trip block grant.

ENTIRE AGREEMENT: This Agreement contains the entire agreement of the parties as to the Understandings and Reimbursements covered herein, and any prior written or oral agreements are merged herein. It shall be construed as jointly drafted, not for or against any party. Both parties acknowledge that they have had the opportunity to be advised by legal counsel of their choosing.

AMENDMENT: This Agreement may be modified or amended only by a written agreement signed by the authorized representatives of the parties.

WAIVER: No waiver of any term or provision of this Agreement will be valid unless such waiver is in writing, signed by the party against whom enforcement of the waiver is sought. The waiver of any term or provision of this Agreement shall not apply to any subsequent breach of this Agreement.

COUNTERPARTS: This Agreement may be executed in several counterparts, each of which shall be deemed an original, but together they shall constitute one and the same instrument.

SEVERABILITY: The provisions of this Agreement shall be deemed severable, and, if any part of any provision is held illegal, void or invalid under applicable law, such provision may be changed to the extent reasonably necessary to make the provision, as so changed, legal, valid and binding. If any provision of this Agreement is held illegal, void or invalid in its entirety, the remaining provisions of this Agreement shall not in any way be affected or impaired but shall remain binding in accordance with their terms.

MEET AND CONFER: Communication is crucial to the ongoing viability of the ENRICH! Program. The District shall advise the MPF Board of Directors in writing, within five business days, of the adoption of any decisions, policies or procedures which would materially affect any provision of this MOU. In the event of any dispute arising under this Agreement, the parties shall meet and confer in good faith to attempt to resolve any issues. The parties may, but are not required, to participate in neutral mediation to facilitate the discussion and resolution process.

Dated: _____

_____ Jim Horn, President GUSD Board of Trustees

_____ Elizabeth Craven, President, MPF Board of Directors

MPF Board Approved: __--18_____ GUSD Board Approved:

**RESOLUTION OF THE GOVERNING BOARD OF THE
GRAVENSTEIN UNION SCHOOL DISTRICT
REGARDING ACCOUNTING OF DEVELOPMENT FEES
FOR 2017-2018 FISCAL YEAR
IN THE FOLLOWING FUND OR ACCOUNT:
FUND 25 - CAPITAL FACILITIES FUND
(Government Code sections 66001(d) & 66006(b))
Resolution #181212-1**

1. Authority and Reasons for Adopting this Resolution.

- A. This District has levied school facilities fees pursuant to various resolutions, the most recent of which is dated December 12, 2017 and is referred to herein as the “School Facilities Fee Resolution” and is hereby incorporated by reference into this Resolution. These resolutions were adopted under the authority of Education Code section 17620. These fees have been deposited in the following fund or account:

Fund 25 – Capital Facilities Fund (the “Fund”);

- B. Government Code sections 66001(d) and 66006(b) require this District to make an annual accounting of the Fund and to make additional findings every five years if there are any funds remaining in the Fund at the end of the prior fiscal year;
- C. Government Code sections 66001(d) and 66006(b) further require that the annual accounting of the Fund and those findings be made available to the public no later than December 27, 2018, that this information be reviewed by this Board at its next regularly scheduled board meeting held no earlier than 15 days after the findings become available to the public, and that notice of the time and place of this meeting (as well as the address at which this information may be reviewed) be mailed at least 15 days prior to this meeting to anyone who has filed a written request for it.
- D. The Superintendent has informed this Board that a draft copy of this Resolution (along with Exhibits 1 and 2 which are hereby incorporated by reference into this Resolution) was made available to the public on November 28, 2018. The Superintendent has further informed this Board that notice of the time and place of this meeting (as well as the address at which this information may be reviewed) was mailed at least 15 days prior to this meeting to anyone who had filed a written request for it.
- E. The Superintendent has also informed this Board that there is no new information which would adversely affect the validity of any of the findings made by this Board in its School Facilities Fee Resolution.

2. What This Resolution Does.

This Resolution makes various findings and takes various actions regarding the Fund as required by and in accordance with Government Code sections 66001(d) and 66006(b).

3. Findings Regarding the Fund.

Based on all findings and evidence contained in, referred to, or incorporated into this Resolution, as well as the evidence presented to this Board at this meeting, the Board finds each of the following with respect to the Fund for the 2017-2018 Fiscal Year:

- A. In reference to Government Code section 66006(b)(2), the information identified in section 1 above is correct;
- B. In further reference to Government Code section 66006(b)(2), this Board has reviewed the annual accounting for the Fund as contained in Exhibit 1 and determined that it meets the requirements set forth in Government Code section 66006(b)(1);
- C. In reference to Government Code section 66001(d)(1)(A), and with respect only to that portion of the Fund remaining unexpended at the end of the 2017-2018 Fiscal Year, the purpose of the fees is to finance the construction or reconstruction of school facilities necessary to reduce overcrowding caused by the development on which the fees were levied, which facilities are more specifically identified in Exhibit 2;
- D. In reference to Government Code section 66001(d)(1)(B), and with respect only to that portion of the Fund remaining unexpended at the end of the 2017-2018 Fiscal Year, the findings and evidence referenced above demonstrate that there is a reasonable relationship between the fees and the purpose for which it is charged as more specifically identified in Exhibit 2;
- E. In reference to Government Code section 66001(d)(1)(C), and with respect only to that portion of the Fund remaining unexpended at the end of the 2017-2018 Fiscal Year, all of the sources and amounts of funding anticipated to complete financing in any incomplete improvements identified as the use to which the fees are to be put is identified in Exhibit 2;
- F. In reference to Government Code section 66001(d)(1)(D), and with respect only to that portion of the Fund remaining unexpended at the end of the 2017-2018 Fiscal Year, the approximate dates on which the funding referred to in paragraph E above is expected to be deposited into the appropriate account or fund is designated in Exhibit 2; and
- G. In reference to the last sentence of Government Code section 66006(d), because all of the findings required by that subdivision have been made in the fees that were levied in paragraphs C-F above, the District is not required to refund any moneys in the Fund as provided in Government Code section 66001(e).

4. Superintendent Authorized to Take Necessary and Appropriate Action.

The Board further directs and authorizes the Superintendent to take on its behalf such further action as may be necessary and appropriate to effectuate this Resolution.

5. Certificate of Resolution.

I, _____, _____ of the Governing Board of the Gravenstein Union School District of Sonoma County, State of California, certify that this Resolution proposed by _____, seconded by _____, was duly passed and adopted by the Board, at an official and public meeting this 12th day of December, 2018, by the following vote:

AYES:

NOES:

ABSENT:

_____ of the Board
of the Gravenstein Union School District
District of Sonoma County, California

EXHIBIT 1

TO RESOLUTION REGARDING ACCOUNTING OF DEVELOPMENT FEES FOR FISCAL YEAR 2017-2018 FOR THE FOLLOWING FUND OR ACCOUNT: FUND 25 – CAPITAL FACILITIES (the “Fund”)

Per Government Code section 66006(b)(1)(A-H) as indicated:

- A. A brief description of the type of fee in the Fund: Gravenstein Union School District collects fees for residential and commercial development on properties within the school district boundaries.
- B. The amount of the fee. The fee is \$1.42 per square foot for residential and \$.21 per square foot for commercial development.
- C. The beginning and ending balance of the Fund.

See Attachment 1.

- D. The amount of the fees collected and the interest earned.

See Attachment 1.

- E. An identification of each public improvement on which fees were expended and the amount of the expenditures on each improvement, including the total percentage of the cost of the public improvement that was funded with fees.

See Attachment 1.

- F. An identification of an approximate date by which the construction of the public improvement will commence if the local agency determines that sufficient funds have been collected to complete financing on an incomplete public improvement, as identified in paragraph (2) subdivision (a) of section 66001, and the public improvement remains incomplete: None available
- G. A description of each interfund transfer or loan made from the account or fund, including the public improvement on which the transferred or loaned fees will be expended, and, in the case of an interfund loan, the date on which the loan will be repaid and the rate of interest that the account or fund will receive on the loan: Not Applicable
- H. The amount of refunds made pursuant to subdivision (e) of section 66001 and any allocations pursuant to subdivision (f) of section 66001: Not Applicable
N/A. No refunds or allocations were made pursuant to subdivision (e) or (f) of section 66001.

EXHIBIT 2

TO RESOLUTION REGARDING ACCOUNTING OF DEVELOPMENT FEES FOR FISCAL YEAR 2017-2018 FOR THE FOLLOWING FUND OR ACCOUNT: FUND 25 – CAPITAL FACILITIES (the “Fund”)

Per Government Code section 66001(d)(1)(A-D) as indicated:

- A. With respect to only that portion of the Fund remaining unexpended at the end of the 2017-2018 Fiscal Year, the purpose of the fees is to finance the construction or reconstruction of school facilities necessary to reduce overcrowding caused by the development on which the fees were levied, which facilities are more specifically identified as follows: Gravenstein Elementary School, Gravenstein First, Hillcrest Middle School
- B. With respect to that portion of the Fund remaining unexpended at the end of the 2017-2018 Fiscal Year, there is a reasonable relationship between the fee and the purpose for which it is charged, including:
 - a. There is an ongoing need for the Fund to complete construction or reconstruction to reduce overcrowding caused by the development.
 - b. The status of improvements identified when the fee was established are as follows: See attachment 2
 - c. The following has been done since the fee was imposed: See attachment 2
 - d. Future plans include: Not determined
- C. With respect to only that portion of the Fund remaining unexpended at the end of the 2017-2018 Fiscal Year, the sources and amounts of funding anticipated to complete financing in any incomplete improvements identified in paragraph A above are as follows: Not yet determined
- D. With respect to only that portion of the Fund remaining unexpended at the end of the 2017-2018 Fiscal Year, the following are the approximate dates on which the funding referred to in paragraph C above is expected to be deposited into the appropriate account or fund: Not yet determined

ATTACHMENT 1
 GRAVENSTEIN UNION SCHOOL DISTRICT
 ANNUAL ACCOUNTING OF DEVELOPER FEES
 FISCAL YEAR 2017-2018

The fee collected in 2017-2018 was \$1.42 per square foot for residential development and \$.21 per square foot for commercial development.

Developer Fees received are deposited in Fund 25 at the Sonoma County Treasury.

Beginning Fund Balance	\$109,761.73
REVENUE	
Fees collected	\$ 9,204.44
Interest	\$ 1,545.49
TOTAL REVENUE	\$ 10,749.93
EXPENDITURES	
Paid to West Sonoma County Transportation For District obligation for facilities	\$ 4,295.41
TOTAL EXPENDITURES	\$ 4,295.41
Fund Ending Balance	\$ 116,216.25

Attachment 2

Ledger99a

Journal Entry Snapshot

Journal Entry Link # 2000028575		Journal Entry # CT18-01349		Type County		Fiscal Year 2018 Transaction Date 03/01/2018	
Created SHOG, 3/6/2018		Posted SHOG, 3/6/2018		Department		Batch #	
Requisition #		Purchase Order #					
Comment: 17-18 Facility Lease, Home to School per LV							
Account #	Comments	Line Seq (Tran Type)	Debits	Credits			
25-0000-0-0000-9200-7299-100-BUS	17-18 Facility Lease, Home to School per LV	1 (X)	1,817.57				
25-0000-0- - -9110- -	17-18 Facility Lease, Home to School per LV	2 ()		1,817.57			
JE # CT18-01349 Totals			1,817.57	1,817.57			

Journal Entry Link # 2000028581

Journal Entry # CT18-01353

Status Posted

Type County

Fiscal Year 2018 Transaction Date 03/01/2018

Created SHOGE, 3/6/2018

Posted SHOGE, 3/6/2018

Department

Requisition #

Purchase Order #

Batch #

Comment 17-18 Spec Ed Facility Lease per LV

Account #	Comments	Line Seq (Tran Type)	Debits	Credits
25-0000-0-0000-9200-7299-100-BUS	17-18 Spec Ed Facility Lease per LV	1 (X)	2,477.84	2,477.84
25-0000-0- - 9110- -	17-18 Spec Ed Facility Lease per LV	2 ()		
JE # CT18-01353 Totals			2,477.84	2,477.84

1
A
M



SCHOOL & COLLEGE LEGAL SERVICES

OF CALIFORNIA

Santa Rosa Office
 5350 Skyline Blvd., Santa Rosa, CA 95403
 Phone: 707-524-2690
 Fax: 707-578-0517

2018-2019 Workshops
 as of November 26, 2018

Eureka Office
 901 Myrtle Avenue, Eureka, CA 95501
 Phone: 707-441-3997

Sonoma County Office of Education 5340 Skyline Blvd., Santa Rosa, CA 95403

DATE	TITLE	PRESENTER	INTENDED AUDIENCE	LOCATION
November 27, 2018 9:00 a.m. - 12:00 p.m. \$45 clients/\$55 non-clients	Confidentiality and Record Retention/Destruction 101 ²	Frank Zotter & Erin E. Stagg	K-12/CCD Administrators, Deputy/Asst. Administrators, Business Managers, and lower-level administrative staff	Redwood Rooms A&B
December 4, 2018 9:00 a.m. - 12:00 p.m. \$45 clients/\$55 non-clients	School Site Administrators: Advanced Special Education Issues ¹	Jennifer E. Nix	K-12 School Site Administrators	Redwood Rooms A&B
December 11, 2018 1:00 p.m. - 5:00 p.m. \$60 clients/\$70 non-clients	Title IX Part IV – Additional Title IX Challenges for Community Colleges ²	Ellie R. Austin & Monica D. Batanero	CCD Administrators, Title IX Coordinators, Deputy Title IX Coordinators, and Equity and Inclusion Staff	Board Room
December 12, 2018 9:00 a.m. – 12:00 p.m. \$45 clients/\$55 non-clients	Layoffs 101 (Classified & Certificated)	Carl D. Corbin	K-12 Staff responsible for layoffs.	Board Room
January 15, 2019 1:00 p.m. - 4:00 p.m. \$45 clients/\$55 non-clients	How to Respond to a Public Records Act Request ²	Erin E. Stagg & Sarah Hirschfeld-Sussman	K-12/CCD Administrators, Deputy/Asst. Administrators, Business Managers, and lower-level administrative staff	Board Room
January 23, 2019 9:00 a.m. - 3:00 p.m. \$75 clients/\$85 non-clients (Lunch Provided)	Human Resources - Personnel Academy ²	Carl D. Corbin	K-12 Staff Responsible for HR Matters	Redwood Rooms A&B

DATE	TITLE	PRESENTER	INTENDED AUDIENCE	LOCATION
February 4, 2019 9:00 a.m. - 12:00 p.m. \$45 clients/\$55 non-clients	Interest Based Bargaining 101 ²	Ellie R. Austin & Sarah Hirschfeld- Sussman	K-12/CCD Negotiating Team Members	Board Room
February 5, 2019 9:00 a.m. - 12:00 p.m. \$45 clients/\$55 non-clients	Special Education: Mental Health Issues ¹	Jennifer E. Nix	K-12 Special Education Staff	Redwood Rooms A&B
February 7, 2019 1:00 p.m. - 5:00 p.m. \$55 clients/\$65 non-clients	Title IX Part III – Nuts and Bolts of the Title IX Coordinator's Role ²	Ellie R. Austin & Monica D. Batenero	K-12/CCD Administrators, Title IX Coordinators, Deputy Title IX Coordinators, and Equity and Inclusion Staff	Redwood Rooms A&B
February 20, 2019 9:00 a.m. - 12:00 p.m. \$45 clients/\$55 non-clients	Review of New Legislation for 2019 ²	Carl D. Corbin	K-12 Board Members and Superintendents	Board Room
February 26, 2019 1:00 p.m. - 4:00 p.m. \$45 clients/\$55 non-clients	Public Contracting ²	Loren W. Soukup & Erin E. Stagg	K-12/CCD Superintendents, Business Mgrs., and Facility Directors	Redwood Rooms A&B
March 6, 2019 9:00 a.m. - 11:00 a.m. \$30 clients/\$40 non-clients	Sexual Harassment Prevention Training ²	Monica D. Batenero	K-12/CCD Supervisory personnel including District Board Members	Board Room
March 14, 2019 9:00 a.m. - 12:00 p.m. \$45 clients/\$55 non-clients	Preschool Special Education A-Z ^{1,2}	Jennifer E. Nix	K-12 School Site Administrators	Redwood Rooms A&B
March 20, 2019 4:00 p.m. - 7:00 p.m. \$45 clients/\$55 non-clients	Brown Act, Ethics, and Conflicts of Interest ^{2**}	Erin E. Stagg	K-12/CCD Board Members, Administrators, Deputy/Asst. Administrators, and Business Managers	Redwood Room C

DATE	TITLE	PRESENTER	INTENDED AUDIENCE	LOCATION
March 28, 2019 10:00 a.m. - 12:00 p.m. \$30 clients/\$40 non-clients	School and Workplace Investigations ²	Monica D. Batanero & Sarah Hirschfeld-Sussman	K-12/CCD Site administrators, HR Staff, Title IX Coordinators, any others who might conduct investigations.	Redwood Rooms A&B
April 4, 2019 9:00 a.m. - 12:00 p.m. \$45 clients/\$55 non-clients	Legal Issues Associated with Individualized Transition Plans ¹	Jennifer E. Nix	K-12 Special Education Staff	Redwood Rooms A&B
April 18, 2019 1:00 p.m. - 4:00 p.m. \$45 clients/\$55 non-clients	Student Discipline Including Special Education ¹	Carl D. Corbin	K-12 Administrators, school psychologists, and special education teachers	Redwood Rooms A&B
April 23, 2019 9:00 a.m. - 12:00 p.m. \$45 clients/\$55 non-clients	Employee Health Leave Rights and Employer Responsibilities ²	Nancy L. Klein	K-12/CCD Any administrator or employee responsible for monitoring or approving employee leaves or for providing notices related to health leaves.	Redwood Rooms A&B
May 16, 2019 9:00 a.m. - 11:00 a.m. \$30 clients/\$40 non-clients	Sexual Harassment Prevention Training ²	Monica D. Batanero	K-12/CCD Supervisory personnel including District Board Members	Redwood Rooms A&B

Workshop dates and times subject to change.

Check <http://www.sclscal.org> for more details regarding the above programs and registration.

If you plan to attend a workshop that indicates lunch is provided and you have any dietary restrictions or special considerations, please notify our office one week prior to the workshop. We will do our best to accommodate you.



SCHOOL & COLLEGE LEGAL SERVICES
OF CALIFORNIA

3

If you are an individual with a disability who needs a special accommodation to attend, please call Linda Lowe at (707) 524-2690 at least 48 hours in advance of the workshop.

¹ This course meets the qualifications for continuing education credit for LEPs, LPCCs, LMFTs, LCSWs, and NCSP. It also qualifies for hours of continuing professional development for Nationally Certified School Psychologists under provider number 1025. The California Association of School Psychologists maintains responsibility for the program and its content. Participants in this training will earn Continuing Education Units – one unit per hour of instruction at the workshop - which can be used toward CASP certification. If you wish to receive credit, add “CEU” after your last name at the time of registration for the workshop. Each registrant wishing to receive credit must submit at the time of the workshop, a check for \$15 made out to CASP and a completed CASP form which SCLS will provide. This payment is separate and in addition to the workshop fee which is paid to SCLS. SCLS will submit the checks and forms for CEU’s to CASP.

² Participants in this training will earn Continuing Education Units for the total length of the workshop, which can be used towards California Association of School Business Officials CASBO certification.

*Our office is in the process of obtaining approval from the California Association of School Business Officials (CASBO) for continuing education credits.

**Workshop is sponsored by the Sonoma County Office of Education. Please visit www.scoe.org for registration.

Advance reservations are necessary and space is limited. You may register on our website at www.sclscal.org, by calling Linda at (707) 524-2690, or by email to register@sclscal.org. The workshop fee must be paid prior to the workshop date and can be done by mailing checks payable to School and College Legal Services to 5350 Skyline Blvd., Santa Rosa, CA 95403 or by faxing a purchase order made out to School and College Legal Services to (707) 578-0517.

The workshop fee will be charged for cancellations received less than seven days prior to the date of the workshop.



Facilities Report
December 12th Board Meeting

Prop 39 Lighting

Moving forward with prop 39 lighting project. Contingent upon board approval of awarding bid with Sylvania. Next steps will be to develop timeline for implementation of installs for LEDS.

Window coverings update:

At Gravenstein going forward with vinyl pull drapes at Gravenstein MPR and trial run of vinyl pull drapes at rm 10 at Gravenstein.

For Hillcrest we are going forward with selecting roller shades for window coverings throughout the campus. We have reached out to three window covering vendors to get them added to our CUPCCAA list. On the legal guidance of schools legal as long as the cost is below \$45,000 we do not have to do a formal bidding process as long as we reach out to qualified companies on our CUPCCAA list. Additionally, this CUPCCAA threshold increases to \$60,000 starting January 1st. We project the bids to be below the \$45,000 threshold for Hillcrest.

With the roller shades we feel they will be easier to clean, more durable, and easier to operate. They are also much more cost effective than the duettes. We have not found the duettes to provide substantial insulation values vs other traditional window coverings.



Gravenstein Elementary School Principal's Report- December 2018

Keri Pugno

December Character Trait- Generosity

grade	Spirit Day	Assembly	Class Project	"I Messages"
All activities led by Grade 1 Team	Holiday Sweater/ Santa Hat Day on Friday, 12/21	School Caroling - led by 1st grade "The best way to spread Christmas Cheer, is singing loud for all to hear."	Secret Santa between the classes Giving tree- tie acts of generosity ornaments to school tree and displayed on campus	I will share my time, talents, and treasures with others. When I give to others without expecting anything back, I show generosity. When I have more than I NEED, I can give to others who have less. I have something worth giving that can make someone's day better or brighter.

Calendar

- Gravenstein Winter Concert for grades 1-5 on Tuesday, 12/18/18, at Hillcrest
- Kindergarten Winter Performance on Friday, 12/21/18, at 9:30 in Gravenstein MPR
- Character Trait Assembly (Generosity) on Friday, 12/21/18, at 1:20
- **TK/Kindergarten Open House**
Date: Saturday, 1/12/19, from 10:00-11:00
Includes: MPR presentation, teacher-led tours, registration paperwork available, and Coach Paige will once again be able to lead activities for students

Grade 3 Students Became Meteorologists!

All of the Gravenstein third graders wrapped up their unit on Weather with a presentation for parents and other classes. Students practiced their public speaking and shared the research they had done on their selected location. Some projects included: houses constructed to withstand the location's climate, video forecasts, graphs, maps, and fun facts.



Trimester 1 Honor Roll Assembly on Monday, 12/10/18, for grades 4-5

- Academic Awards
- Character Trait/Citizenship Awards: September- Courage, October- Compassion, November- Leadership

Lunch Recess Activities

- Kindergarten Structured Activities led by Mr. Ray
- Grades 3-5 IntraMural Games led by Mr. Clinton and Mr. Ray
- New... Coach Paige has started weekly activities for both the TK/K and Grades 1/2 AM recess.



MPR is up and running! It is wonderful having full access to our MPR. It looks beautiful and the MPR Use calendar is filling up. Current activities include: daily lunch service, rainy day lunch, Coach Paige if raining, Dance, Drama, classroom play rehearsals, preparation for Kindergarten Winter Performance, and afterschool play space for Beyond-the-Bell on rainy days.



Continued Monitoring on Breakfast Option

Breakfast/Snack offerings continue to be successfully managed with current plan:

- ~20 identified children made aware of healthy food options available in office for no cost: apple, string cheese, granola bar, box of raisins
- On a regular basis, 3-4 students accessing the offerings
- Process has become efficient and students are independent
- Teachers know they can reach out if access offerings whenever new students are identified
- Keri Pugno monitors amounts and restocks on weekends (Reimbursed through requisition process).

I recommend we continue with this option as students' needs are being met with a minimal amount of staffing, funds, paperwork, student embarrassment, impact on school schedule and learning.

Kindergarten Discovery! Program Pilot Update (report included later in agenda)

Gravenstein Kindergarten Discovery! 2018-2019

Pilot Program Update December, 2018



What's Working Well?

1. Enrollment numbers are high
2. Kindergarten Kick-Off great way to "start" year
3. Enrichment for all at grade level
4. Regular exposure to Spanish, Dance, Drama, Art, Music, Athletic Movement, Mr. Science
5. Structured recess activity supports student needs
6. Growth in academics and improvements in school readiness/student behavior

Original Challenges	How initially addressed	Support/Solutions still needed	December Update
Larger number of students not "school ready"	teacher modifications in class, parent communication	increased parent communication regarding school readiness expectations; increased staff support	Remains a Valid Concern- Working with K Team to address this before next year (promotion/advertising message, grade level brochure on expectations, preparation page included in registration packet, email reminder sent over summer, increase communication). (bold = completed in time for 2019-2020 registration packet/Open House)
Differentiation needs are greater within each class and greater among the grade as they are equally spread among all 4 classrooms	placed instructional aide support in each classroom for limited support/partial day (Currently one IA splits time between two K classrooms, yet still covers recess/yard duty, and has required breaks)	increase instructional aide support so that there is a dedicated support person for each of the instructional periods (8:45-10:00; 10:15-11:45; 12:30-2:15 = 4.5 hours) and/or hire a K-2 Reading Intervention Specialist	Remains a Valid Concern- still need to fill positions
increased activities creates an increase in transitions- which are disruptive to instruction and behaviors	analyze enrichment schedule for remaining trimesters to see if possible to adjust schedule	Perhaps not start enrichments until third week of school to allow for more preparation. Perhaps build up to a full day (ie August dismissal at 1:30, begin 2:15 dismissal in September)	Ability of student to transition from classroom teacher to Specials activity/instructor has improved.
recess behavior	Created Alternate Recess Activity for students (this has allowed classroom teacher to start class on time after recess, decreased student office visits, and decreased student/parent reports of peer misbehavior)	Start year with enough yard coverage that this option can occur as soon as a need is observed.	No longer a concern. Structured group has become a desired activity, so we have arranged for Coach Paige to lead a 1x week recess game for all TK/K students.
academic levels unusually diverse in each of the four classrooms	IA in classrooms	Increase IA time (and training) Hire/Restructure so there is a K-2 Reading Intervention Specialist to help serve the needs of the ones who most need it.	Remains a Valid Concern- hourglass distribution of skills is still an accurate representation of student abilities.
5 different SA/ instructors causing increased confusion/behaviors	analyze enrichment schedule for remaining trimesters to see if possible to adjust schedule	Focus Activities on gross motor, fine motor, and language (Spanish, Coach Paige, Music, and Art). Reevaluate when in the year subjects should be taught.	Improvements noted as experience with instructors increased. Benefit noted from familiarity and consistency of instructors. K Team has begun discussing ideas on how to structure/schedule the Enrichment/Special classes for next year to proactive address this challenge.

Kindergarten Teacher Initial Recommendations

Recommendations are made at this time, with the understanding that these may change as more time allows for further pilot analysis.

Extend Kindergarten Discovery/ pilot to two years. More time is needed before any expansion considered.

Maintain dual program starting for grades 1-5.

Create a behavioral screening process.

Plan to extend the early August Kindergarten Kick-off to three days.

Increase school-home communication regarding school preparation (hold pencil, sit at carpet, listen to story, color, cut)

Hire a K-2 Reading Specialist to focus on early Literacy Intervention

Increase Instructional Aide time to allow for an aide in each classroom for differentiation and immediate behavioral support.

Current Recommendations

Yes; support Discovery/ program model, but still need to determine specific details.

K Team's decisions are specific to K; defer 1-5 decisions to 1-5 teachers Staff committee to create schoolwide behavioral expectations for all to support.

Yes- 3 day Kick-off

Yes- "publish" expectations
Yes; create additional supports for struggling students (and/or resources for Teachers)
Yes- still need to hire

Board Report
November 2018

Generosity- Generosity is the theme for the month of December and Hillcrest Middle School students are displaying this life skill through two different activities--

1)Hessel Church Canned Food Drive - Monday, December 3, to Friday, December 14. This is a community service project as well as a House competition. Students will bring in non-perishable canned or boxed foods to help local families in need.

2)Hillcrest Community Service Project -Shoebboxes for homeless of Sonoma County. As part of our service to our community Hillcrest families are invited to participate in the Shoebox Project. Shoebboxes will be filled with necessities suitable for both men and women. The boxes will be wrapped in Christmas paper and delivered to the Homeless Services Center in Santa Rosa.

12 Days of Blue Feathers- Starting on December 6th, we have been drawing Blue Feathers each school day until December 21st, the day before winter break! On December 6th we drew 12 Blue Feathers and those 12 students all won a prize. On December 7th we drew 11 Blue Feathers and those 11 students each won and so on until December 21st where one student will win \$50 in cash! Remember students can earn Blue Feathers for being caught doing something right or helping out around the Hillcrest campus!

Pajama Jammy Jam—The Pajama Jammy Jam, the Winter Dance, is Friday December 14th at 7:00 pm in Hillcrest Hall! Tickets go on sale in the Duck Pond on Wednesday December 12th for \$5.00- tickets can be purchased at the night of the dance at the door for \$8.00. Students may come dressed in their pajamas!

Hillcrest Awards Assembly- The 1st Trimester awards assembly will take place on Friday December 21st. Students will be recognized for earning above a 3.0 GPA, for excelling in the different subjects and for displaying the themes of Self Confidence, Leadership and Generosity. This year we will hold three separate

assemblies - one for each grade level. 6th grade will start at 9:20, 7th grade at 11:00 and 8th grade at 1:15.

Update on Modernization Funding

New Construction –

Jack Schreder and Associates notified the District that all available methodologies were used to calculate the new construction eligibility however, the analysis continues to show that the District is not eligible.

Modernization –

Hillcrest and Gravenstein’s modernization eligibility was analyzed for enrollment increases and additional area overage. There were no changes this year. Jack Schreder & Associates provided a GUSD Funding Summary by Project report which is attached. They also noted that the Office of Public School Construction (OPSC) is currently processing funding applications which were submitted to them in the *fall of 2014*.



**Gravenstein Union Elementary School District Funding Summary by Project
Projects as of November 7, 2018**

Site	Project #	Project Scope	State's SFP Share	District's Share	Total Project Eligibility
Projects Submitted to OPSC and Pending OPSC Application Review (Projects are listed on the OPSC Acknowledged Applications Received Past Existing Authority list)					
Gravenstein Elementary Submitted to OPSC 5/17/18	57/003	Phase II modernization	\$2,571,676	\$1,714,453	\$4,286,129
Subtotal of Projects Submitted to OPSC and Pending OPSC Application Review (Projects are listed on the OPSC Workload List)			\$2,571,676	\$1,714,453	\$4,286,129

GRAVENSTEIN UNION ELEMENTARY SCHOOL DISTRICT
2017/18 State Modernization Funding Estimate

School Name	Estimated Eligibility*							Regular Grant	50 Year Old Grant	Project Assistance	Fire Detection	Small Size Project	3% ADA Compliance	State Share (60%)	District Share (40%)	Total Project Cost**	
	Regular Pupils		50 Year Old Pupils														Total
	K-6	7-8	NS	S	K-6	7-8	NS										
Gravenstein	0	0	0	0	0	0	0	0	\$ -	\$ -	\$ -	\$ -	\$ -	\$ -	\$ -	\$ -	
Hillcrest	4	1	0	0	56	9	0	0	70	\$ 22,274	\$ 400,903	\$ 3,772	\$ 10,010	\$ 50,781	\$ 12,695	\$ 333,624	
Totals							70	\$ 22,274	\$ 400,903	\$ 3,772	\$ 10,010	\$ 50,781	\$ 12,695	\$ 500,435	\$ 333,624	\$ 834,059	

*The estimated figures require the Office of Public School Construction review and approval of the 2017/18 eligibility update.

**Funding estimates do not include potential additional eligible augmentations. The estimates require the Office of Public School Construction review and approval of funding application documents.

School Name	Additional area coverage in:
Gravenstein	Site is 100% coverage
Hillcrest	2020 & 2026

In order to submit an SAB 50-04 Application for Modernization Funding the following documents are required:

- DSA approved plans & specifications
- DSA approved letter
- DSA approved access compliance checklist, if applicable
- DSA approved fire life safety checklist, if applicable
- CDE final plan approval letter
- Career Technical Education Certification letter, JSA to provide
- SAB 50-04 Application for Funding, JSA to provide
- Detailed construction cost estimate

Grade Level	2018 Pupil Grant (Regular)	2018 Pupil Grant (50 yr)	2018 Fire Detection
K-6	\$ 4,404	\$ 6,119	\$ 143
7-8	\$ 4,658	\$ 6,471	\$ 143
9-12	\$ 6,099	\$ 8,471	\$ 143
Non-Severe	\$ 9,391	\$ 13,041	\$ 264
Severe	\$ 14,037	\$ 19,502	\$ 394

ESTIMATED SFP MODERNIZATION ELIGIBILITY BASELINE ADJUSTMENT WORKSHEET

School District: Gravenstein Union Elementary

Application No. 57/0714-00-

Site: Gravenstein Elementary K-5

County Sonoma

SAB Approval	Baseline Adjustments Adjustments to Baseline Eligibility + or -				Type	Type of Adjustment Pursuant to Section 1859.51	Net Baseline Eligibility					
	K - 6	7 - 8	9 - 12	Non-Severe			Severe	K - 6	7 - 8	9 - 12	Non-Severe	Severe
	7/28/99	125	135	0			0	0	Establish eligibility with 1998/99 CBEDS. No SDC pupils.	125	135	0
12/6/06	150	-135	0	0	0	errors & omissions (originally approved as a K-8. adjusted to reflect K-5) & 2005/06 CBEDS	275	0	0	0	0	0
12/6/06	-104	0	0	0	0	57/002 Unfunded	171	0	0	0	0	0
1/27/07	0	0	0	0	0	57/002 Funded	171	0	0	0	0	0
Filed 10/31/13	0	0	0	0	0	12/13 CBEDS increase. However no additional eligibility generated because eligibility is capped by the capacity. Submit to lock in CBEDS increase. (filed 10/31/13)	171	0	0	0	0	0
Filed 4/12/17	109	0	0	31	7	2016/17 CBEDS increase & additional area coverage in 2017 Option A to B (filed 4/12/17)	280	0	0	31	7	7
1/17/18	16	0	0	1	0	Additional area coverage for 2018 (filed 1/17/18)	296	0	0	32	7	7
Filed 5/17/18	-296	0	0	-32	-7	57/pending (filed 5/17/18)	0	0	0	0	0	0

CBEDS last used = 2016/17 @ 439 (K-5 400, 32 non-severe & 7 severe)

2017/18 CBEDS = 438

Site is 100% coverage

ESTIMATED SFP NEW CONSTRUCTION ELIGIBILITY BASELINE ADJUSTMENT WORKSHEET

School District: Gravenstein Union Elementary

Application No. 50/70714-00-

Site: Districtwide

County Sonoma

SAB Approval	Baseline Adjustments					Type	Type of Adjustment Pursuant to Section 1859.51				Net Baseline Eligibility			
	Adjustments to Baseline Eligibility													
	+ or -													
7/28/99	K - 6	-219	7 - 8	-89	9 - 12	0	0	0	0	0	0	0	0	0
TBD		124	90	0	0	0	0	0	0	0	1	-89	0	0

1. District is less than 2,501 pupils.
2. Small school districts with less than 2,501 pupils may "lock in" their new construction eligibility for up to three years from the date of State Allocation Board Approval (SAB).
3. The 2017/18 eligibility update will NOT be submitted as the net baseline eligibility is negative.
4. The District's eligibility will be "locked" for 3 years from the latest eligibility update approved by the SAB.

Board Agenda Calendar 2018—2019

Gravenstein Union School District

July 2018	<ol style="list-style-type: none"> 1. Williams Report for Previous Quarter 2. Attendance Projections for Current Year 3. Approve Spring Consolidated Application 4. Review and Approve Parent Handbook for Current Year 5. Review Goals & Accomplishments for Previous Year 6. Begin Superintendent Evaluation for Previous Year 7. Update Mandatory Board Policies 8. Summer School Update (if applicable)
August 2018	<ol style="list-style-type: none"> 1. Begin Development of Goals and Objectives for Current Year 2. Complete Superintendent Evaluation for Previous Year 3. Review and Approve Field Trips for Current Year
September 2018	<ol style="list-style-type: none"> 4. Review and Approve Unaudited Actuals for Prior Year (by 9/15) 5. Adopt Gann Limit (by 9/30) 6. Budget Update 7. Report on School Opening and Attendance 8. Approve Site Plan if appropriate 9. State Testing Report 10. Complete Goals & Objectives for Current Year (if necessary)
October 2018	<ol style="list-style-type: none"> 1. Williams Report for Previous Quarter 2. Budget Update 3. Public Hearing and Approve Resolution on Sufficiency of Instructional Materials 4. Certification of Compliance with Standards-Aligned Instructional Materials 5. Continue to review Board Policy
November 2018	<ol style="list-style-type: none"> 1. Approve Resolution on Accounting of Developer Fees 2. Continue to Review Board Policies
December 2018	<ol style="list-style-type: none"> 1. Board Reorganization 2. Review and Approve 1st Interim Budget Report (by 12/15) 3. Discuss Kindergarten Registration and Promotional Events

January 2019	<ol style="list-style-type: none"> 1. Williams Report for Previous Quarter 2. Set Deadlines for Charter School Admissions and Lotteries 3. Budget Update 4. Acceptance of Financial Audit for Previous Year (by 1/31) 5. Enrollment and Staffing Projections for Upcoming Year
February 2019	<ol style="list-style-type: none"> 1. Review and Approve School Accountability Report Cards 2. Review and Approve District Safety Plan for Upcoming Year 3. Update Educator Effectiveness Plans for Current Year
March 2019	<ol style="list-style-type: none"> 1. Employment Lay-off/Non-reelect Notices (if necessary—by 3/15) 2. Staff Contracts for Psychologist, Nurse, Art, Speech Therapist etc. for Upcoming Year 3. Review / Approve 2nd Interim Budget Report for Current Year (by 3/17) 4. Approve Consolidated Application for Upcoming Year 5. Approve Single Plan for Student Achievement (SPSA) 6. Update Enrollment and Staffing Projections for Upcoming Year 7. 5 Year Deferred Maintenance Plan (if applicable) 8. REACH MOU Update for Upcoming Year 9. Approve District Calendar for Upcoming Year
April 2019	<ol style="list-style-type: none"> 1. Williams Report for Previous Quarter 2. Approve Auditor Contract for Upcoming Year(s) 3. End of the Year Events Calendar 4. GUTA Sunshines Contract Proposal for Upcoming Year
May 2019	<ol style="list-style-type: none"> 1. Final Lay-off Notices to Certificated Staff (if necessary—by 5/15) 2. Update Enrollment and Staffing Projections for Upcoming Year 3. Review Summer Maintenance Plans (Paving, painting, etc.) 4. Approval of the Hillcrest Promotion List 5. Board Sunshines District Contract Proposal for Upcoming Year
June 2019	<ol style="list-style-type: none"> 1. Public Hearing and Adoption of LCAP/Budget for Upcoming Year (by 6/30—requires two separate meetings) 2. Adoption of Site Plan 3. Adopt Education Protection Account (EPA) Resolution

December 2018	TK	K	1	2	3	4	5	6	7	8	Totals
Teachers	TK	K	1	2	3	4	5	6	7	8	Totals
Tomsky	21										21
Trivunovic		20									20
Redfern		20									20
Crandall		20									20
Briggs		20									20
Dellosa			18								18
Clement			18								18
Candau ENRICH!			18								18
Lannon ENRICH!			19								19
Otterson				17							17
Sprinkle				19							19
DeBolt ENRICH!				20							20
Basque ENRICH!				21							21
Barrera					15						15
Haas					16						16
Mattish ENRICH!					24						24
Nordstrom ENRICH!					24						24
Martinez						19					19
Carey						21					21
Sully ENRICH!						22					22
Brown ENRICH!						21					21
Grimm							22				22
Squires							22				22
Gorman ENRICH!							26				26
Hansen ENRICH!							24				24
Helton								10			10
Kinman								12			12
Dexter ENRICH!								24			24
Rich ENRICH!								23			23
McDowell									21		21
Sotiras									19		19
Collins ENRICH!									27		27
Clements ENRICH!									25		25
Cole										20	20
Jex-Lewis										5	5
Blanco										25	25
Johnson ENRICH!										20	20
Sporrer ENRICH!										17	17
Parsons CDS				1						1	2
Community Day School				1						1	2
Gravenstein Campus	21	80	73	77	79	83	94				507
Hillcrest Campus								69	92	87	248
December 2018	21	80	73	78	79	83	94	69	93	87	757
December 2017	21	60	79	80	85	88	75	85	88	76	737
December 2016	13	75	79	80	80	78	75	78	87	80	725
December 2015	6	94	76	83	68	78	76	89	83	85	738
December 2014		90	78	66	69	68	74	72	83	111	711
December 2013		98	65	70	66	70	62	73	101	107	712
December 2012		73	68	69	61	68	67	85	111	101	703
December 2011		78	69	59	67	62	84	88	92	79	678
December 2010		66	55	58	52	82	72	83	78	92	638

2017
488
249
737

CALPADS FALL 1

2018-19 COUNTY-LEVEL CERTIFICATION REPORT

Sonoma County - 49

CDS Code	LEA Type	LEA Name	2017-18 Certified Enrollment	2018-19 Completed Enrollment	Enrollment Percent Completed	Fatal Errors	Anomaly Percent	2018-19 Certification Status
49-70599-0000000	D	Alexander Valley Union Elementary	116	110	94.83%	0	0%	Certified
49-70615-0000000	D	Bellevue Union	1,698	1,621	95.47%	0	0.0858%	Certified
49-70623-0000000	D	Bennett Valley Union Elementary	1,022	995	97.36%	0	0.1494%	Ready
49-70649-0000000	D	Cinnabar Elementary	259	245	94.59%	35	0%	Not Certified
49-70656-0000000	D	Cloverdale Unified	1,440	1,375	95.49%	0	0.0707%	Certified
49-73882-0000000	D	Cotati-Rohnert Park Unified	5,861	5,766	98.38%	0	0.0938%	Ready
49-73882-0123786	IR	Crede High	337	400	118.69%	0	0%	Ready
49-70672-0000000	D	Dunham Elementary	193	155	80.31%	27	0%	Not Certified
49-70680-0000000	D	Forestville Union Elementary	263	237	90.11%	0	0%	Certified
49-70698-0000000	D	Fort Ross Elementary	19	21	110.53%	0	0%	Certified
49-70706-0000000	D	Geyserville Unified	237	232	97.89%	0	0.2083%	Ready
49-70714-0000000	D	Gravenstein Union Elementary	724	761	105.11%	0	0%	Certified
49-70722-0000000	D	Guerneville Elementary	262	258	98.47%	12	0.1838%	Not Certified
49-70722-0136465	IR	California STEAM Sonoma II	16	655	4093.75%	0	4.2916%	Certified
49-70730-0000000	D	Harmony Union Elementary	256	249	97.27%	0	0.1961%	Certified
49-70730-6120588	IR	Pathways Charter	396	403	101.77%	0	0.1171%	Ready
49-75390-0000000	D	Healdsburg Unified	1,531	1,440	94.06%	0	0%	Certified
49-70763-0000000	D	Horticon Elementary	62	69	111.29%	3	0.7042%	Not Certified
49-70888-0000000	D	Kashia Elementary	12	15	125%	0	0%	Certified
49-70789-0000000	D	Kenwood	141	138	97.87%	0	0%	Ready
49-70797-0000000	D	Liberty Elementary	215	212	98.5%	0	0.2203%	Certified
49-70797-0107284	IR	California Virtual Academy @ Sonoma	628	622	99.04%	52	1.3081%	Not Certified
49-70805-0000000	D	Mark West Union Elementary	1,459	1,444	98.97%	0	0%	Certified
49-70813-0000000	D	Monte Rio Union Elementary	89	84	94.38%	0	0%	Certified
49-70821-0000000	D	Montgomery Elementary	35	33	94.29%	0	1.4286%	Ready
49-70839-0000000	D	Oak Grove Union Elementary	854	853	99.88%	0	0.1736%	Ready
49-70839-0120584	IR	Pivot Online Charter - North Bay	381	32	8.4%	0	5.9524%	Not Certified
49-70839-0138065	IR	Pivot Charter School - North Bay	0	357	0%	0	0.3472%	Certified

CALPADS FALL 1

2018-19 COUNTY-LEVEL CERTIFICATION REPORT

Sonoma County - 49

CDS Code	LEA Type	LEA Name	2017-18 Certified Enrollment	2018-19 Completed Enrollment	Enrollment Percent Completed	Fatal Errors	Anomaly Percent	2018-19 Certification Status
COUNTY TOTALS								
			69,746	69,459	99.59%	1,045	20.5616%	

Table Column: Content Descriptions

LEA Type

"D" denotes the LEA as a district. "IR" denotes the LEA as an independently reporting charter (IRC) school and they report CALPADS data independently of their authorizing LEA.

2018-19 Completed Enrollment

Count of open student enrollment records on Information Day, including those that have a grade change update but not a complete student information update. As a result, some completed enrollment counts in this report may differ from the total enrollment count produced in Snapshot Report 1.1: Enrollment-Primary Status by Subgroup.

Enrollment Percent Completed

The percentage of current year enrollments that have been completed compared to prior year. Calculated by dividing current year Completed Enrollment by last year Certified Enrollment. The Completed Enrollment Percent will be displayed as zero percent (0%) if the LEA or IRC did not have prior year certified enrollment.

Certification Status

- Certified** - There is only Certified. Certified Level 1 and 2 have been removed from the new CALPADS system.
- Ready** - LEAs with a status of "Ready" have not yet certified, but have zero (0) Fatal Errors and an Anomaly Percent less than 2%, both of which are required for certification.
- Not Certified** - LEAs with a status of "Not Certified" may have to resolve Fatal Errors and or bring down their Anomaly Percent before they are ready to certified.
- Not Ready** - A status of "Not Ready" is assigned to LEAs who have zero enrollment for the current year.

CERTIFICATION STATUS

STATUS	COUNT
Certified	29
Ready	14
Not Certified	10
Not Ready	0

COUNTY LEA COUNT

LEA TYPE	COUNT
District	41
IRC	12
TOTAL	53

CALPADS FALL 1

2018-19 COUNTY-LEVEL CERTIFICATION REPORT

Sonoma County – 49

CDS Code	LEA Type	LEA Name	2017-18 Certified Enrollment	2018-19 Completed Enrollment	Enrollment Percent Completed	Fatal Errors	Anomaly Percent	2018-19 Certification Status
49-70847-0000000	D	Old Adobe Union	1,931	1,907	98.76%	0	0.0772%	Certified
49-70847-0119750	IR	River Montessori Elementary Charter	166	182	109.64%	0	0.5208%	Ready
49-70854-0000000	D	Petaluma City Elementary	2,097	2,170	103.48%	1	0%	Certified
49-70854-6119036	IR	Live Oak Charter	294	293	99.66%	0	0%	Certified
49-70862-0000000	D	Petaluma Joint Union High	5,337	5,358	100.39%	0	0%	Certified
49-70870-0000000	D	Piner-Olivet Union Elementary	1,358	1,259	92.71%	204	0.1921%	Not Certified
49-70896-0000000	D	Rincon Valley Union Elementary	3,442	3,307	96.08%	0	0.0289%	Certified
49-70904-0000000	D	Roseland	2,874	2,913	101.36%	0	0.202%	Certified
49-70912-0000000	D	Santa Rosa Elementary	5,112	4,931	96.46%	486	0.4514%	Not Certified
49-70912-6116958	IR	Kid Street Learning Center Charter	134	116	86.57%	0	0%	Certified
49-70920-0000000	D	Santa Rosa High	11,186	11,221	100.31%	224	0.3615%	Not Certified
49-70938-0000000	D	Sebastopol Union Elementary	491	463	94.3%	0	0.3165%	Certified
49-70938-0120121	IR	REACH	122	144	118.03%	0	0.6329%	Ready
49-70938-6113039	IR	Sebastopol Independent Charter	292	293	100.34%	0	0.3378%	Certified
49-10496-0000000	D	Sonoma County Office of Education	575	546	94.96%	0	0.5043%	Ready
49-70953-0000000	D	Sonoma Valley Unified	4,451	4,330	97.28%	0	0%	Ready
49-70961-0000000	D	Twin Hills Union Elementary	1,206	1,207	100.08%	0	0.4472%	Certified
49-70979-0000000	D	Two Rock Union	154	166	107.79%	0	0.8824%	Ready
49-70995-0000000	D	Waugh Elementary	877	854	97.38%	1	0%	Not Certified
49-71001-0000000	D	West Side Union Elementary	182	178	97.8%	0	0%	Certified
49-70607-0000000	D	West Sonoma County Union High	1,959	1,933	98.67%	0	0.0756%	Certified
49-71019-0000000	D	Wilmar Union Elementary	257	243	94.55%	0	0%	Certified
49-75358-0000000	D	Windsor Unified	5,078	5,080	100.04%	0	0%	Ready
49-75358-0114934	IR	Village Charter	98	103	105.1%	0	0%	Certified
49-71035-0000000	D	Wright Elementary	1,567	1,480	94.45%	0	0%	Certified

